

General Description:

The FSM Series is a high-performance, smart VSD (Variable Speed Drive) water booster pump designed for consistent water pressure in residential and small commercial systems. With advanced control features and compact design, it's the perfect solution for modern water supply needs.



Key Features:

- **Smart Pressure Control:** Automatically adjusts pump speed based on demand to maintain steady pressure, reduce energy use, and improve efficiency.
- **Durable Stainless Steel Build:** Features a stainless steel pump body and impeller for long-lasting corrosion resistance and reliability.
- **Quiet Performance:** Engineered to run at low noise levels (around 50 dB), making it ideal for indoor or discreet installations.
- **Easy-to-Use Interface:** Includes a digital LCD display and simple control panel for monitoring performance and adjusting settings with ease.
- **Built-In Safety Protection:** Offers dry-run protection, thermal overload protection, and temperature safeguards to protect both pump and plumbing systems.
- **Compact, All-in-One Design:** Streamlined unit is easy to install, space-saving, and requires minimal maintenance.



Performance Curves

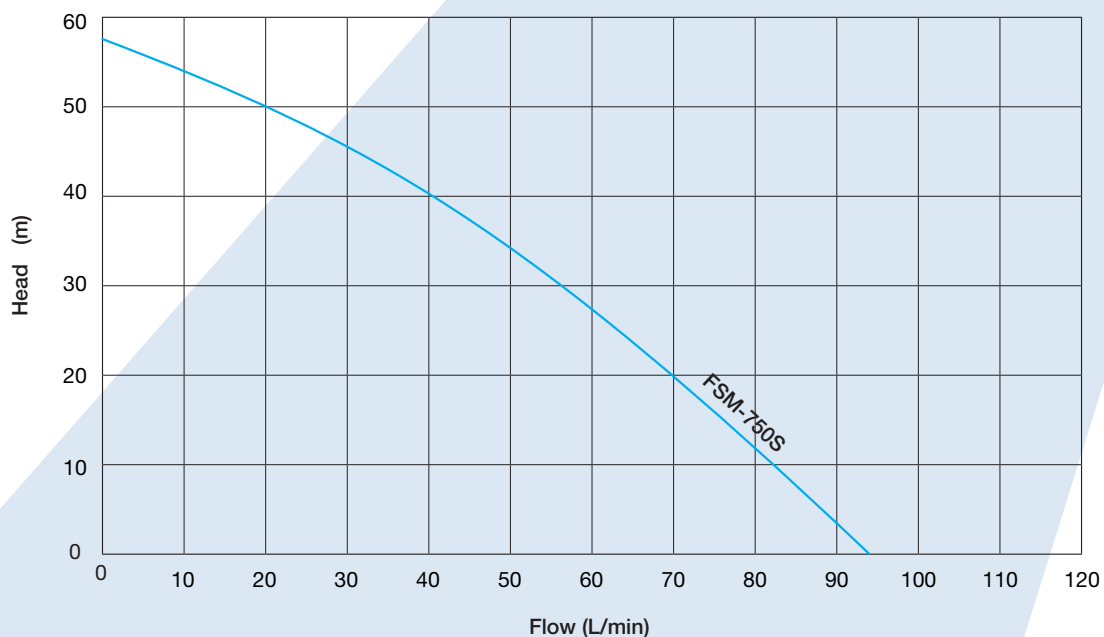

Applications:

- **Domestic Water Pressure Boosting:** Ensures reliable water pressure for homes, units, and small buildings – perfect for taps, showers, and appliances.
- **Garden & Lawn Irrigation:** Provides consistent pressure for hose reels, sprinklers, or automated irrigation setups.
- **Hot Water & Floor Heating Systems:** Compatible with closed-loop heating systems to maintain water circulation and temperature control.
- **Multi-Storey Water Supply:** Effectively boosts water pressure in two- or three-level homes or other buildings with elevation challenges.
- **Light Commercial Use:** Suitable for cafes, motels, and pressure boosting in compact commercial setups.

Technical Details

| MODEL | POWER (P2) | | MAX. FLOW (L/min) | MAX. HEAD (m) | MAX. SUCT (m) | MAX. TEMP |
|-----------------|-------------|------------|-------------------|---------------|---------------|---------------|
| | kW | HP | | | | |
| FSM-750S | 0.75 | 1.0 | 93 | 58 | 5 | 0-40°C |

Dimensions

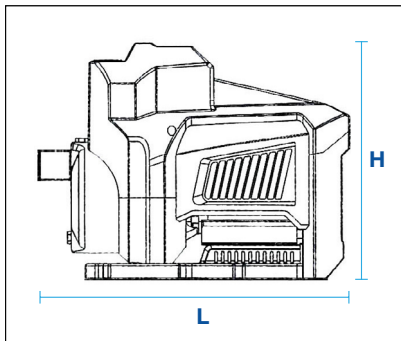

| Pump Model | Size (mm) | | | Inlet x Outlet (mm) | Kg |
|-----------------|------------|------------|------------|---------------------|------------|
| | H | L | W | | |
| FSM-750S | 290 | 390 | 195 | 25 x 25 | 9.2 |