



KAMAT

since 1974



Portfolio

PLUNGER PUMPS

Pumps | Valves | Applications

HIGH-PRESSURE TECHNOLOGY AND SOLUTIONS BY KAMAT

Customised plunger pumps for any industrial application

We are a German manufacturer of industrial crankshaft-driven plunger pumps with three or five plungers for pressures ranging from 0 bar to more than 3500 bar and up to 1500 kW power input.

Being in the market since 1974, and with a worldwide distribution net, we are experienced in designing and producing high-pressure technology and high-pressure solutions for our customers.

Our well-known design flexibility of high-pressure plunger pumps and components allows us to cover most of the possible applications. These can be divided into three general groups: water jetting, hydraulics and process technology.

MODULAR DESIGN MAKES IT EASY TO FIND THE RIGHT PUMP

As a high-pressure system supplier KAMAT designs and manufactures plunger pumps using a modular system: each pump type is based on a certain size gear box and assembled from different recombined modules for various applications up to 3500 bar and 1500 kW.

Our present pump portfolio gives an overview of our eleven pump types, our two pump heads and our different pump and hydraulic valves. As a first step, it introduces our customers to our modular system. Further details can always be discussed with our sales experts and engineers.

Even if the requested pump is not in our portfolio at first glance, we are able to find the right solution for any project! Providing individual and custom-made high-pressure solutions – that is what we can!

PUMP POWER INPUT

	max. flow	max. pressure	max. power input
K100-3	7 l/min	2000 bar	15 kW
K4500-3	232 l/min	2000 bar	45 kW
K8000-3G	283 l/min	2950 bar	75 kW
K9000-3G	283 l/min	3100 bar	90 kW
K11000-3G	454 l/min	2760 bar	110 kW
K18000-3G	522 l/min	3500 bar	180 kW
K25000-3G	1148 l/min	3200 bar	250 kW
K45000-3G	1310 l/min	3500 bar	450 kW
K55000-5G	1913 l/min	3500 bar	550 kW
K100000-5G	3482 l/min	3500 bar	1000 kW
K150000-5G	4677 l/min	3500 bar	1500 kW

UNIQUE KAMAT FEATURES

- made from high-quality materials sourced in Germany
- stainless as standard, special materials available
- 100% designed and manufactured in Germany
- pump body made as a single forged component thus reducing failure probability due to a lack of seals
- compact, low weight to power ratio, extremely small footprint
- low NPSHr thus preventing cavitation
- optimised for VFD drive
- high particle tolerance thus no high demands on the fluid's filtration up to 350 µm
- easy to install, to service and to maintain
- high viscosity fluids
- low number of mostly interchangeable parts – less seals, less leaks, lower failure probability
- simple service, without dismantling the gear box or pump head removal, no hoist needed
- pumps are supported worldwide
- API 674, ATEX, MA, EAC (GOST), EN ISO 9001
- customised sealing solutions
- > 90% efficiency

MAIN FIELDS OF APPLICATION



Hydraulics



Process Industry



Jetting



Mining



KAMAT PLUNGER PUMPS

- K100-3**
- max. 2000 bar
 - max. 7 l/min
 - max. 15 kW
 - 25 kg



- K819000-3G**
- max. 3100 bar
 - max. 283 l/min
 - max. 75/90 kW
 - 255 kg

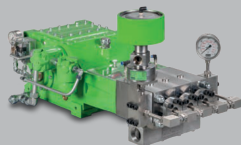

- K18000-3G**
- max. 3500 bar
 - max. 522 l/min
 - max. 180 kW
 - 440 kg



- K45000-3G**
- max. 3500 bar
 - max. 1310 l/min
 - max. 450 kW
 - 1360 kg

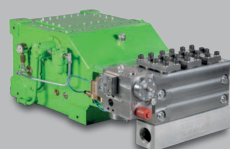

- K100000-5G**
- max. 3500 bar
 - max. 3482 l/min
 - max. 1000 kW
 - 3650 kg

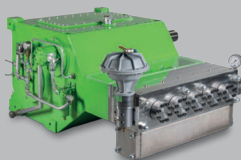

- K4500-3**
- max. 3000 bar
 - max. 232 l/min
 - max. 45 kW
 - 195 kg



- K11000-3G**
- max. 2760 bar
 - max. 454 l/min
 - max. 110 kW
 - 425 kg

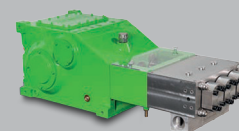

- K25000-3G**
- max. 3200 bar
 - max. 1148 l/min
 - max. 250 kW
 - 965 kg

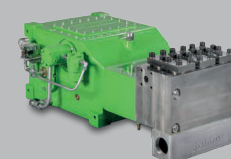

- K55000-5G**
- max. 3500 bar
 - max. 1913 l/min
 - max. 550 kW
 - 2200 kg

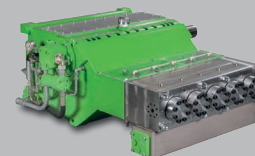

- K150000-5G**
- max. 3500 bar
 - max. 4677 l/min
 - max. 1500 kW
 - 7500 kg

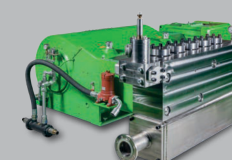

HYDRAULIC VALVES

- PRESSURE LIMITING VALVES**
- max. 4000 bar
 - max. 4600 l/min



- UNLOADER VALVES**
- max. 700 bar
 - max. 3600 l/min

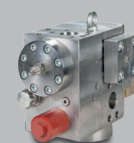

- CONTROL VALVES**
- max. 3500 bar
 - max. 240 l/min



- SAFETY VALVES**
- max. 4000 bar
 - max. 4700 l/min



PUMP HEADS

M - HEAD

- pressure range 0 - 1000 bar
- filtration < 350 µm
- valve design vertical
- plate and soft valves

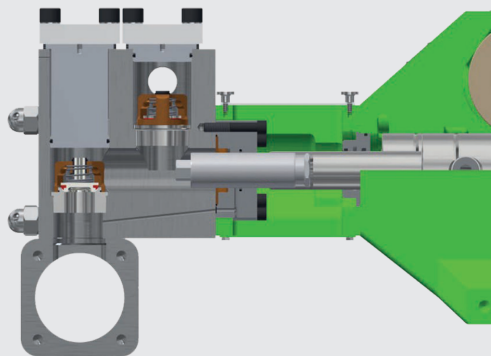

A - HEAD

- pressure range 0 - 3500 bar
- filtration < 100 µm
- valve design horizontal
- load cycle free

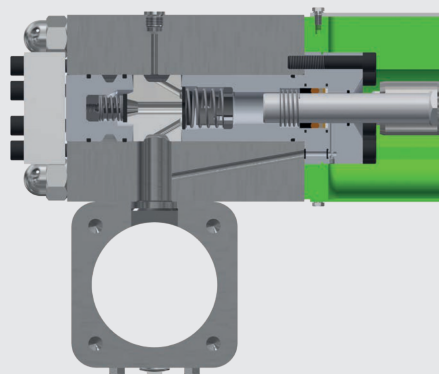

PUMP HEAD VALVES

M VALVE PLATE

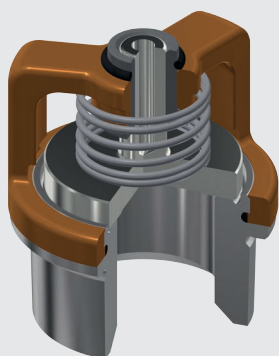

M VALVE SOFT

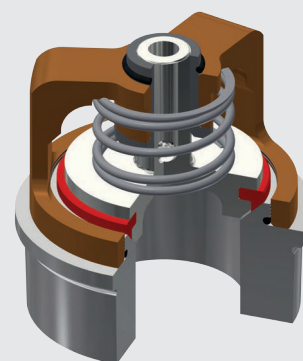

A VALVE

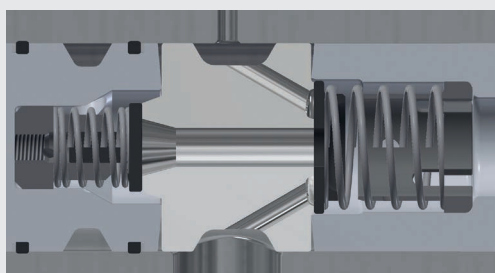

WIDE RANGE FOR ALL APPLICATIONS

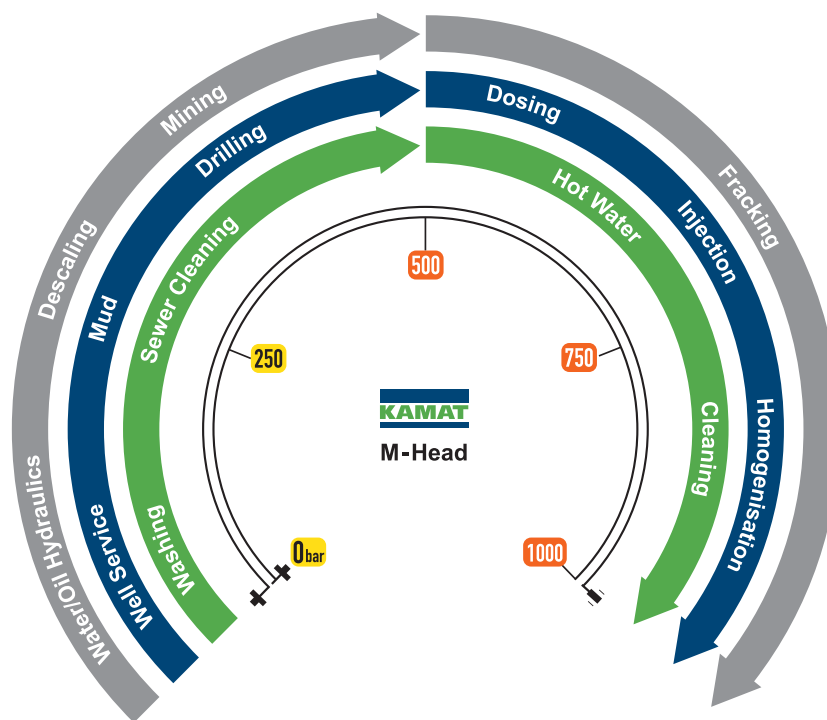

M2
M
Jetting
Process Industry
Hydraulics

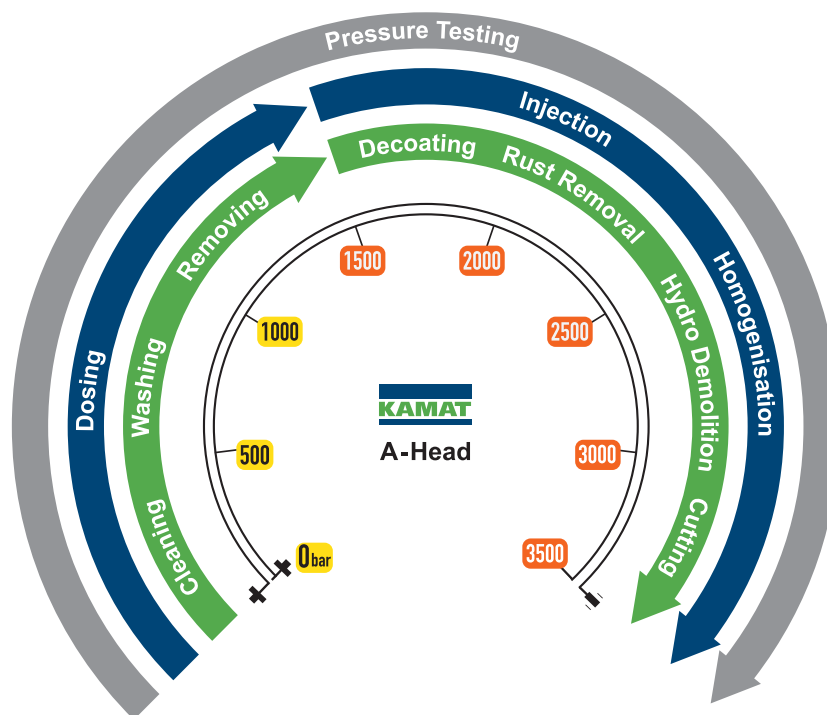

A2
A1
Jetting
Process Industry
Hydraulics

INSIDE VIEWS OF OUR PUMPS

M-Head

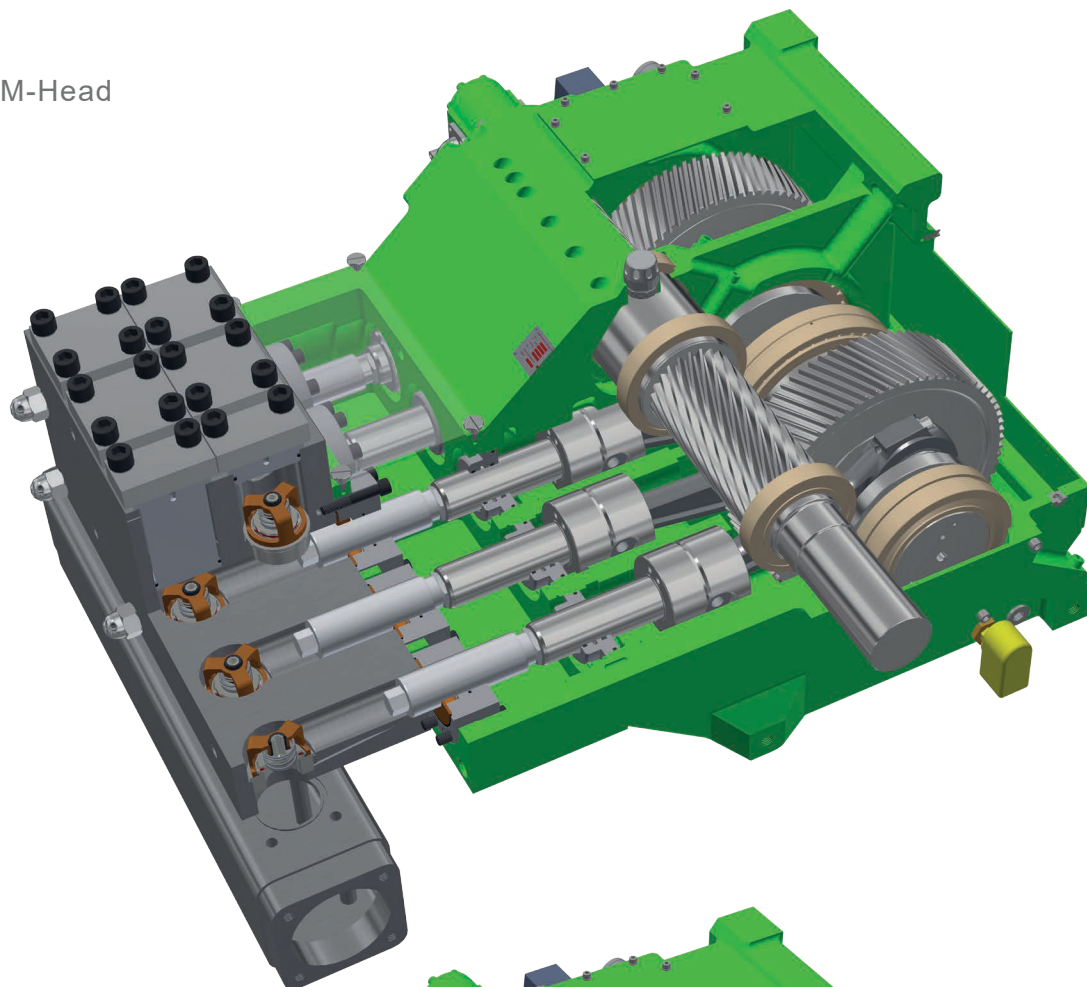

A-Head

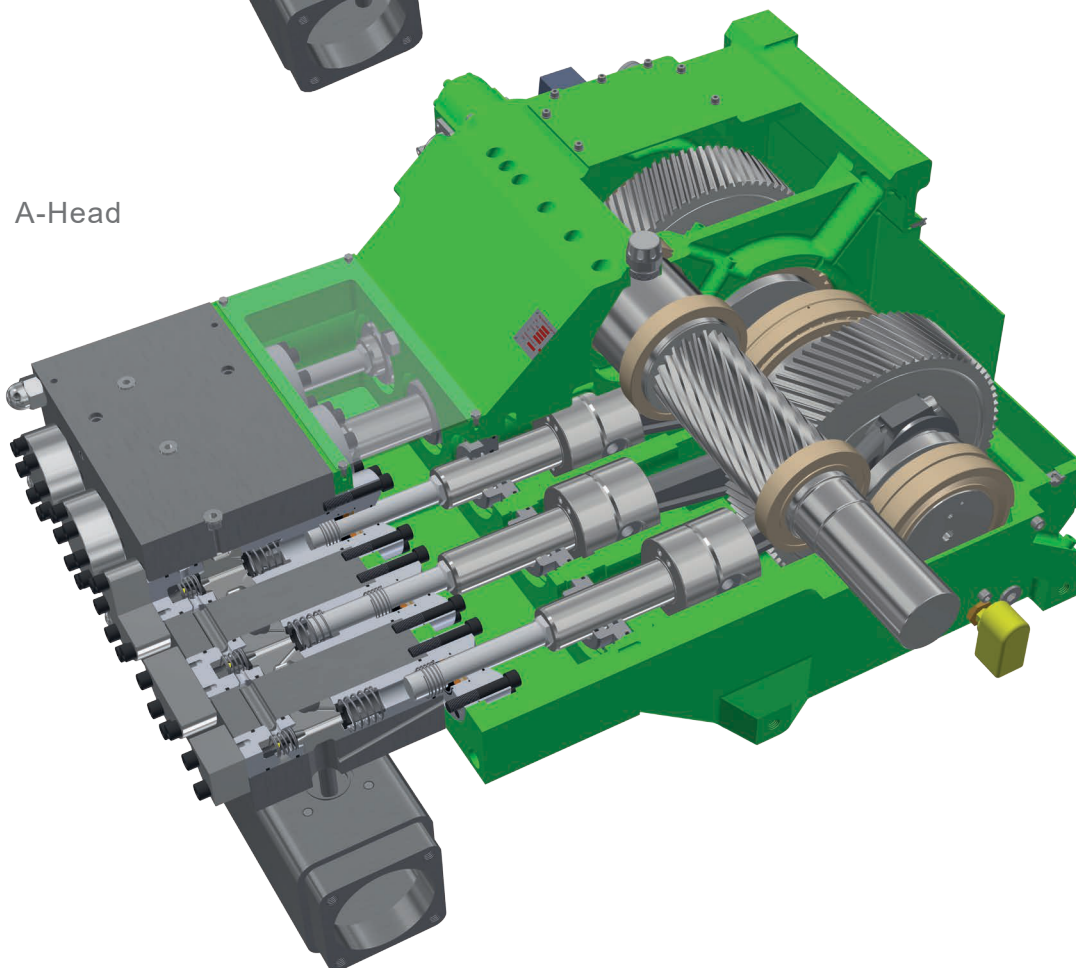

KAMAT WORLDWIDE

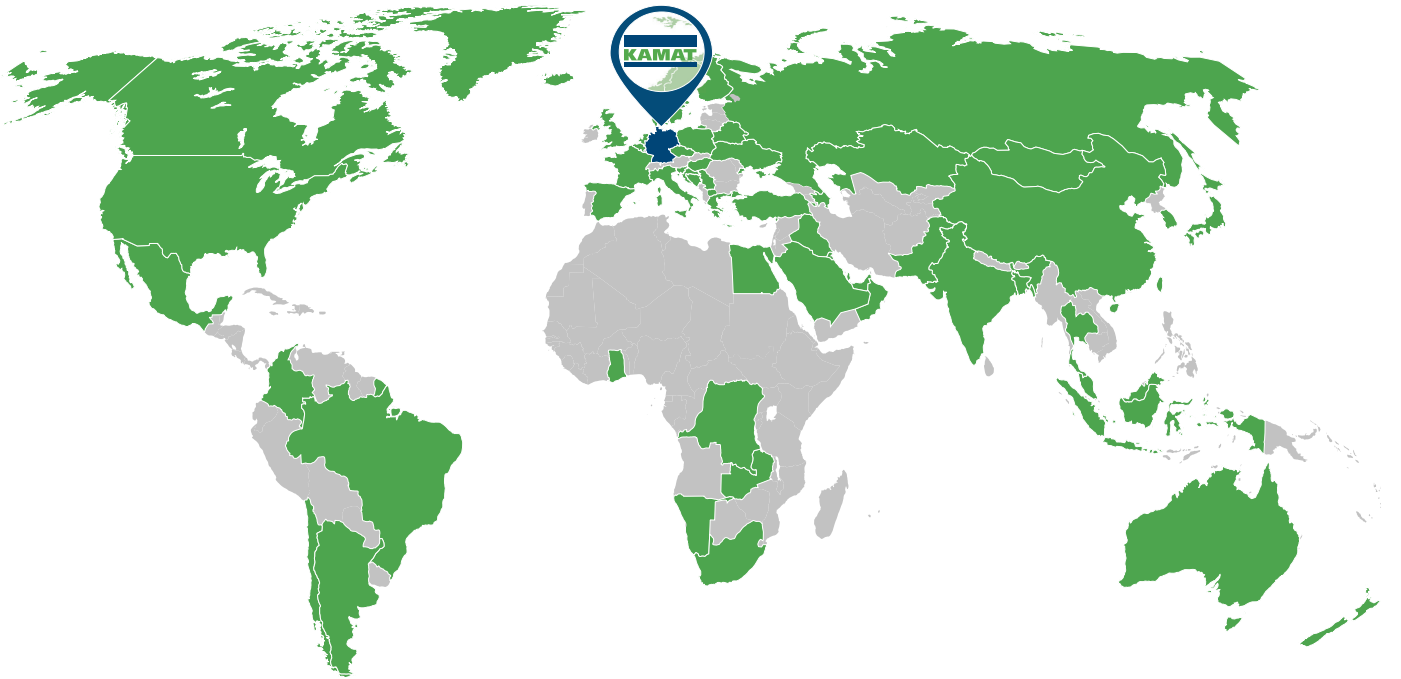

EUROPE: Belarus | Belgium | Bosnia and Herzegovina | Croatia | Czech Republic | Denmark | Finland | France | Germany | Great Britain | Greece | Hungary | Iceland | Italy | Netherlands | North Macedonia | Norway | Poland | Serbia | Slovenia | Spain | Sweden | Ukraine
ASIA: Azerbaijan | China | India | Indonesia | Israel | Japan | Kazakhstan | Malaysia | Mongolia | Russia | South Korea | Taiwan | Turkey | Thailand | United Arab Emirates
AFRICA: Dem. Rep. Congo | Egypt | Ghana | Namibia | South Africa | Zambia
NORTH AMERICA: Canada | Mexico | United States of America
SOUTH AMERICA: Argentina | Brazil | Colombia | Chile
OCEANIA: Australia | New Zealand

Official New Zealand partner:



0800 786 774
www.pumpandvalve.com



+49 2302 8903 0
info@KAMAT.de
www.KAMAT.de/en

