

AUTOWELLWASHER™

The AutoWellWasher™ has been in the Australasian marketplace for 25 years and is still the preferred method in keeping pump stations fat free.

The AutoWellWasher™ will reduce maintenance in wet wells and tanks that accumulate fats, oils and greases (FOGs). Our design uses town water or recycled treated effluent at mains pressure to keep pump stations clean. It can be installed using existing telemetry or with our pre-programmed timing device that activates towards the end of the pump out cycle.

*'The total water usage for a single washer
is as little as 100 litres per day.'*

Installing a wellwasher will eliminate large fatty build-up in pump stations, this then reduces blockages in pumps and downstream sewers. The level sensors remain clean so the pumps work more efficiently, reducing the risk of overflows due to FOG build-up.

It has also been shown to significantly reduce sulphide corrosion on concrete walls, pumps and other internal infrastructure components.

There are fewer confined space entries required, only when essential maintenance tasks are needed.

The AutoWellWasher™ is wholly designed and manufactured in Australia and has Australian, United States & International Patents.

*The principle behind the
design is simple:*

*The AutoWellWasher™
cleans the fat and grease away
before it solidifies.*

WHY CHOOSE THE AUTOWELLWASHER™

- ELIMINATES FAT & GREASE BUILD-UP ON INFRASTRUCTURE & WALLS
- NO POWER REQUIRED
- OPERATES WITH MAINS PRESSURE WATER
- USES LESS THAN 100 LTS WATER Per/DAY
- CLEANER LEVEL SENSOR PROBES
- REDUCES OVERFLOWS CAUSED BY FOGs
- REDUCES ODOUR
- REDUCES CONFINED SPACE ENTRIES
- REDUCES INFRASTRUCTURE CORROSION
- REDUCES MAINTENANCE
- IMPROVED SAFETY AT PUMP STATIONS
- REDUCES CUSTOMER COMPLAINTS
- HEALTHIER ENVIRONMENT

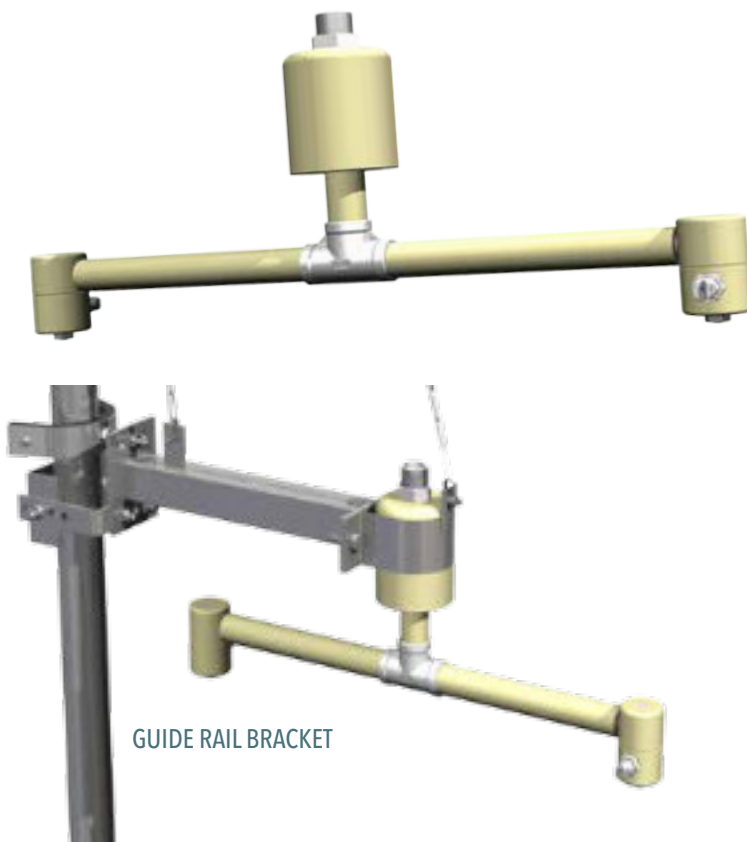

GUIDE RAIL BRACKET

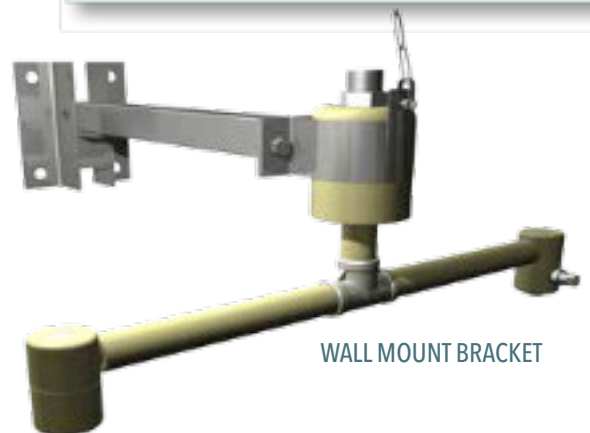

WALL MOUNT BRACKET

PUMP & VALVE SPECIALTIES LTD

100 MONTGOMERIE ROAD, AIRPORT OAKS, AUCKLAND 2022

OFFICE PHONE: 0800 786 774

AUTOWELLWASHER™ INSTALLATIONS



AUTOWELLWASHER™ IN PUMP STATION



AUTOWELLWASHER™ ON GUIDE RAIL BRACKET



AUTOWELLWASHER™ IN PUMP STATION ON WALL MOUNT BRACKET

PUMP & VALVE SPECIALTIES LTD

100 MONTGOMERIE ROAD, AIRPORT OAKS, AUCKLAND 2022

OFFICE PHONE: 0800 786 774

www.pumpanvalve.com

0800 786 774

PUMP&VALVE
SPECIALTIES LTD