

VAriable Speed COntroller

Operating manual

VASCO



Index

1. VASCO Introduction.....	3
2. Safety Instructions.....	3
3. Technical Characteristics	4
3.1 Weight and dimensions	5
4. Electric wiring.....	6
4.1 Protections	12
4.2 Electromagnetic compliance.....	12
4.3 Installation with long motor cables	12
5. VASCO installation.....	13
5.1 VASCO Installation for constant pressure control	16
5.1.1 Pressure tank	16
5.1.2 Pressure sensor	16
6. VASCO Use and Programming	17
6.1 VASCO display	17
6.2 Initial configuration.....	17
6.3 Initial view	19
6.4 Menu view.....	20
6.5 Installer parameters.....	20
6.6 Advanced parameters.....	25
7. Protections and alarms.....	28
8. Auxiliary pumps during constant pressure control	29
8.1 DOL pumps.....	30
8.2 COMBO function	31
9. Trouble-shooting chart	34
10. Technical Assistance	35

1. VASCO Introduction

VASCO is a variable frequency drive designed to control and protect pumping systems by varying the output frequency to the pump.

VASCO can be applied to both new and existing pumping systems, and provides:

- energy and cost savings
- simplified installation and an overall lower pumping system cost
- longer life of the pumping system and relevant components
- improved reliability

VASCO, when connected to any pump, manages the system operation to maintain a certain constant physical quantity (pressure, differential pressure, flow, temperature, etc.) regardless of the conditions of use. The pump is operated only when needed thus avoiding unnecessary energy consumption.



VASCO at the same time is able to:

- protect the motor from overload and dry running
- implement soft start and soft stop to increase the system life and reduce current peaks
- provide an indication of current consumption, voltage, and power
- maintain a record of run time and display any errors and/or failures reported by the system
- control up to two additional pumps at a constant speed (Direct On Line)
- connect to other VASCO units for combined operation

Through the use of inductive filters (optional) VASCO eliminates dangerous surges that are induced in long cables, making VASCO suitable for control of submersible pumps.

2. Safety Instructions

The manufacturer strongly suggests carefully reading this operation manual before using and installing its products. Any operation (installation, maintenance and repair) must be carried out by trained, skilled, and qualified personnel. Failure to observe and follow the instructions in this manual may result in dangerous and potentially lethal electric shock. Pay attention to all standard safety and accident prevention regulations.

	<p>The device must be connected to main power supply via a switch to ensure the complete disconnection from the network before any operation on the VASCO itself (including visual inspection) and/or on the connected load.</p>
	<p>Disconnect VASCO from the main power supply before commencing any work.</p> <p>Do not remove, for any reason, the cover and the cable plate without having first disconnected the device from the main power supply and having waited at least 5 minutes.</p> <p>VASCO and pumping system must be grounded properly before operation. For the entire period VASCO is powered, high voltage is present on the output terminals of the inverter whether or not the pump is running.</p> <p>Tightening all screws on the cover with washers is recommended before powering the device. Otherwise, there may be a failure to connect the cover to ground, creating the risk of electric shock or even death.</p>

Avoid any shock or significant impact during transport.

Check the VASCO immediately upon delivery and check for damage and/or missing parts. If either occurs, immediately notify the supplier.

Damages due to transport, incorrect installation, or improper use of the device will null and void the warranty.

Tampering or disassembly of any component will automatically void the warranty.

The manufacturer cannot be held responsible for any damages to people and/or property due to improper use of its products.

3. Technical Characteristics

Model	Vin +/- 15% [V]	Max V out [V]	Max I in [A]	Max I out [A]	P2 motor power* [kW]	Size
VASCO 209	1 x 230	1 x Vin	15	9	1,1	1
		3 x Vin		7	1,5	1
VASCO 214	1 x 230	1 x Vin	20	9	1,1	1
		3 x Vin		11	3	1
VASCO 218	1 x 230	3 x Vin	38	18	4	2
VASCO 225	1 x 230	3 x Vin	53	25	5,5	2
VASCO 306	3 x 230	3 x Vin	10	6	1,1	1
VASCO 309	3 x 230	3 x Vin	13,5	9	2,2	1
VASCO 314	3 x 230	3 x Vin	16	14	3	2
VASCO 318	3 x 230	3 x Vin	21	18	4	2
VASCO 325	3 x 230	3 x Vin	31	25	5,5	2
VASCO 330	3 x 230	3 x Vin	35	30	7,5	2
VASCO 338	3 x 230	3 x Vin	42	38	9,2	3
VASCO 348	3 x 230	3 x Vin	52	48	11	3
VASCO 365	3 x 230	3 x Vin	68	65	15	3
VASCO 375	3 x 230	3 x Vin	78	75	18,5	3
VASCO 385	3 x 230	3 x Vin	88	85	22	3
VASCO 406	3 x 380 - 460	3 x Vin	10	6	2,2	1
VASCO 409	3 x 380 - 460	3 x Vin	13,5	9	4	1
VASCO 414	3 x 380 - 460	3 x Vin	16	14	5,5	2
VASCO 418	3 x 380 - 460	3 x Vin	21	18	7,5	2
VASCO 425	3 x 380 - 460	3 x Vin	31	25	11	2
VASCO 430	3 x 380 - 460	3 x Vin	35	30	15	2
VASCO 438	3 x 380 - 460	3 x Vin	42	38	18,5	3
VASCO 448	3 x 380 - 460	3 x Vin	52	48	22	3
VASCO 465	3 x 380 - 460	3 x Vin	68	65	30	3
VASCO 475	3 x 380 - 460	3 x Vin	78	75	37	3
VASCO 485	3 x 380 - 460	3 x Vin	88	85	45	3

- Power frequency: 50 - 60 Hz (+/- 2%)
- Max. ambient temperature at nominal current: 40°C (104 °F)
- Max. altitude at nominal current: 1000 m
- Grade of protection: IP55 (SIZE 1,2) , IP54 (SIZE 3) *
- RS485 serial communication

* auxiliary cooling fan of the VASCO, used in wall mounted applications, has a protection rating of IP54.

VASCO is able to power the motor with a higher current for a short period of time according to the linear relation: 101% of the nominal current for 10min., 110% nominal current for 1 min.

3.1 Weight and dimensions

Model	Weight *	Size
	[Kg]	
VASCO 209	4	1
VASCO 214	4,3	1
VASCO 218	7,2	2
VASCO 225	7,2	2
VASCO 306	4,4	1
VASCO 309	4,4	1
VASCO 314	7	2
VASCO 318	7	2
VASCO 325	7	2
VASCO 330	7,2	2
VASCO 338	33	3
VASCO 348	33	3
VASCO 465	34	3
VASCO 375	34	3
VASCO 385	34	3
VASCO 406	4,4	1
VASCO 409	4,4	1
VASCO 414	7	2
VASCO 418	7	2
VASCO 425	7	2
VASCO 430	7,2	2
VASCO 438	33	3
VASCO 448	33	3
VASCO 465	34	3
VASCO 475	34	3
VASCO 485	34	3

* Weight without packing.

SIZE 1

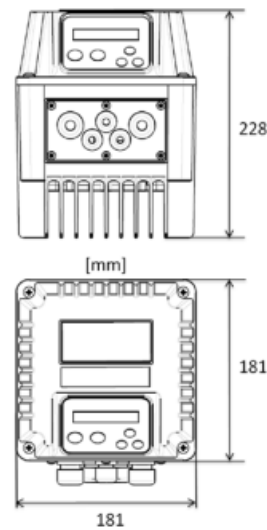

SIZE 2

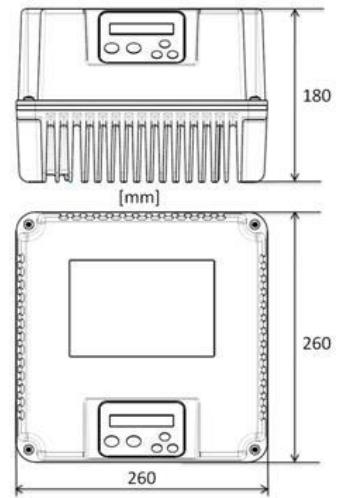

SIZE 3

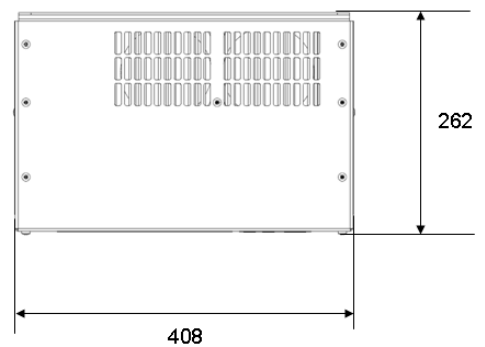
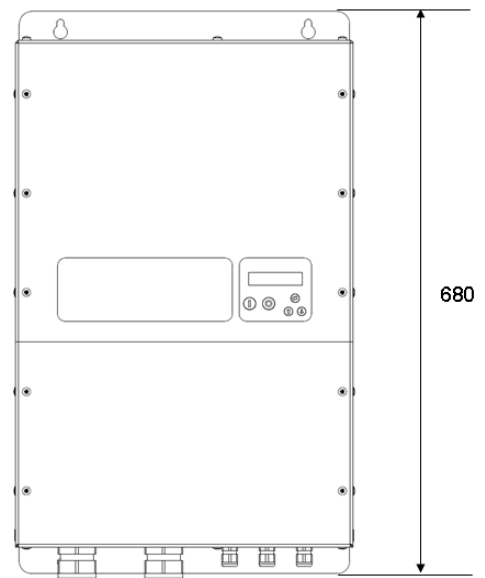

4. Electric wiring

Power board VASCO 209,214

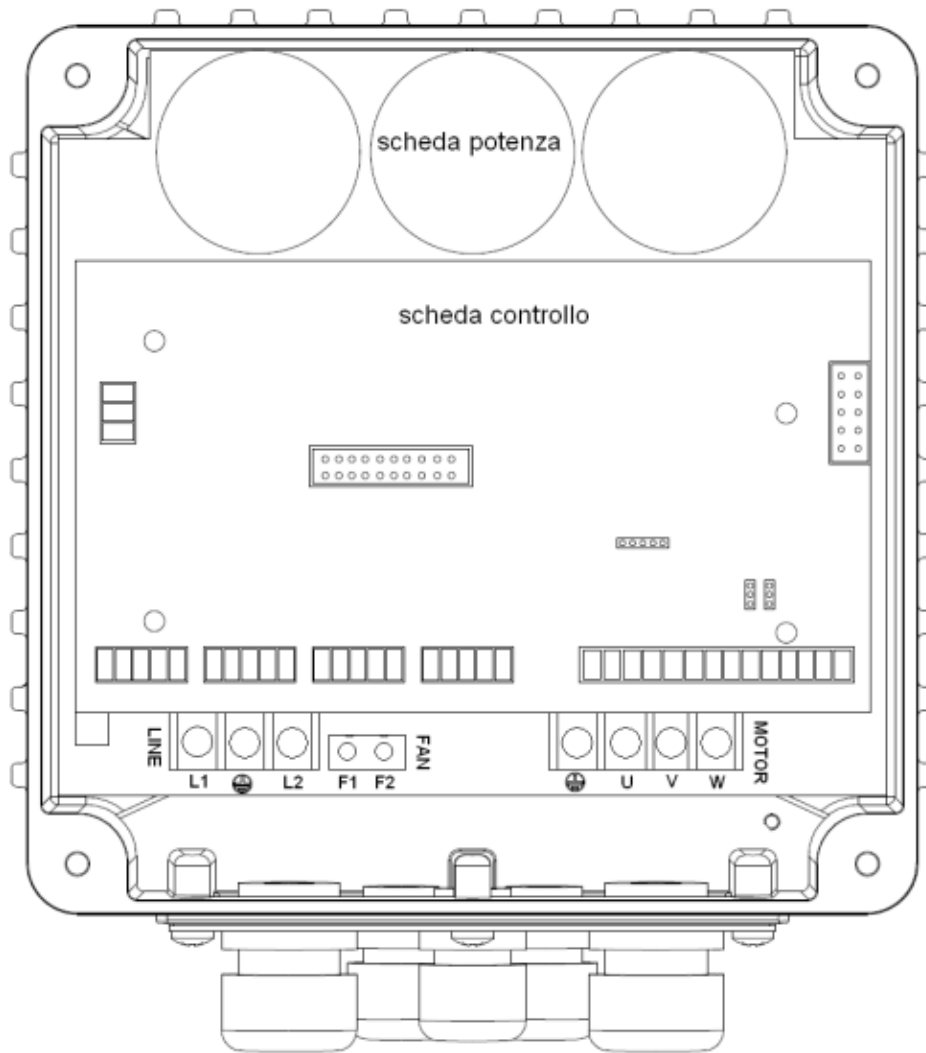

<p>Power supply: LINE: L1, L2,GND It is recommended to use cable lugs</p>	<p>Output: 3 ph motor: GND,U,V,W, 1 ph motor: earth, U (running), V (common) It is recommended to use cable lugs.</p>	<p>230 V AC auxiliary fans (wall mounting kit) FAN: F1, F2</p>
--	--	--

Recommended line and motor cables stripping

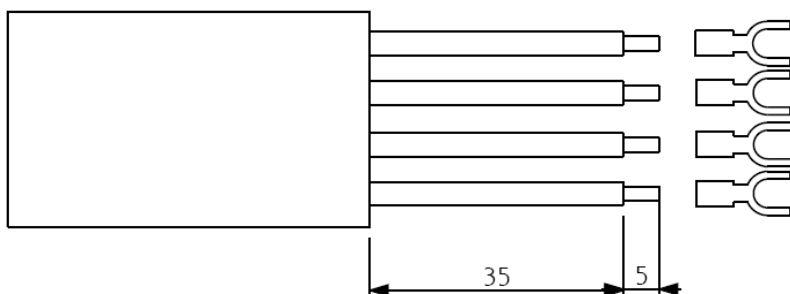

Power board VASCO 218, 225

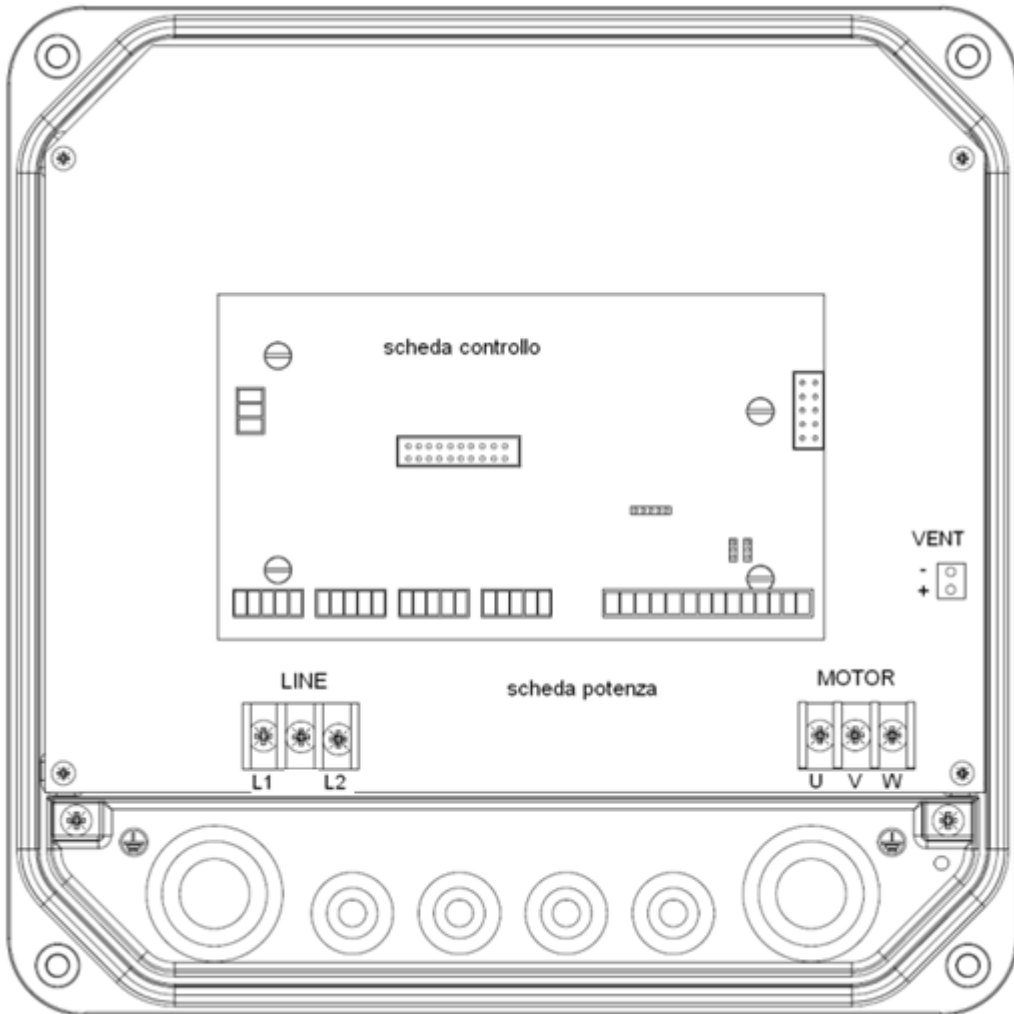

<p>Power supply: LINE: L1, L2, GND It is recommended to use cable lugs.</p>	<p>Motor output: MOTOR: U, V, W, GND It is recommended to use cable lugs.</p>	<p>12 V dc auxiliary fans (wall mounting kit) VENT: +, - WARNING: respect the polarity.</p>
--	--	---

Cable stripping recommended for line input and output to the motor.

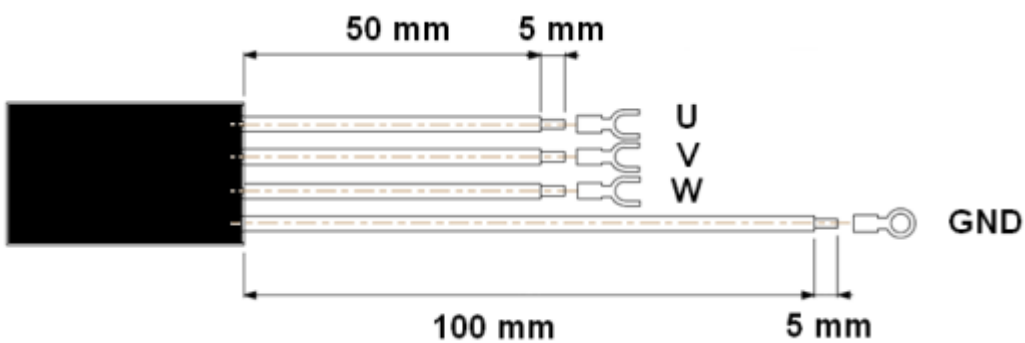

Power board VASCO 306,309,406,409

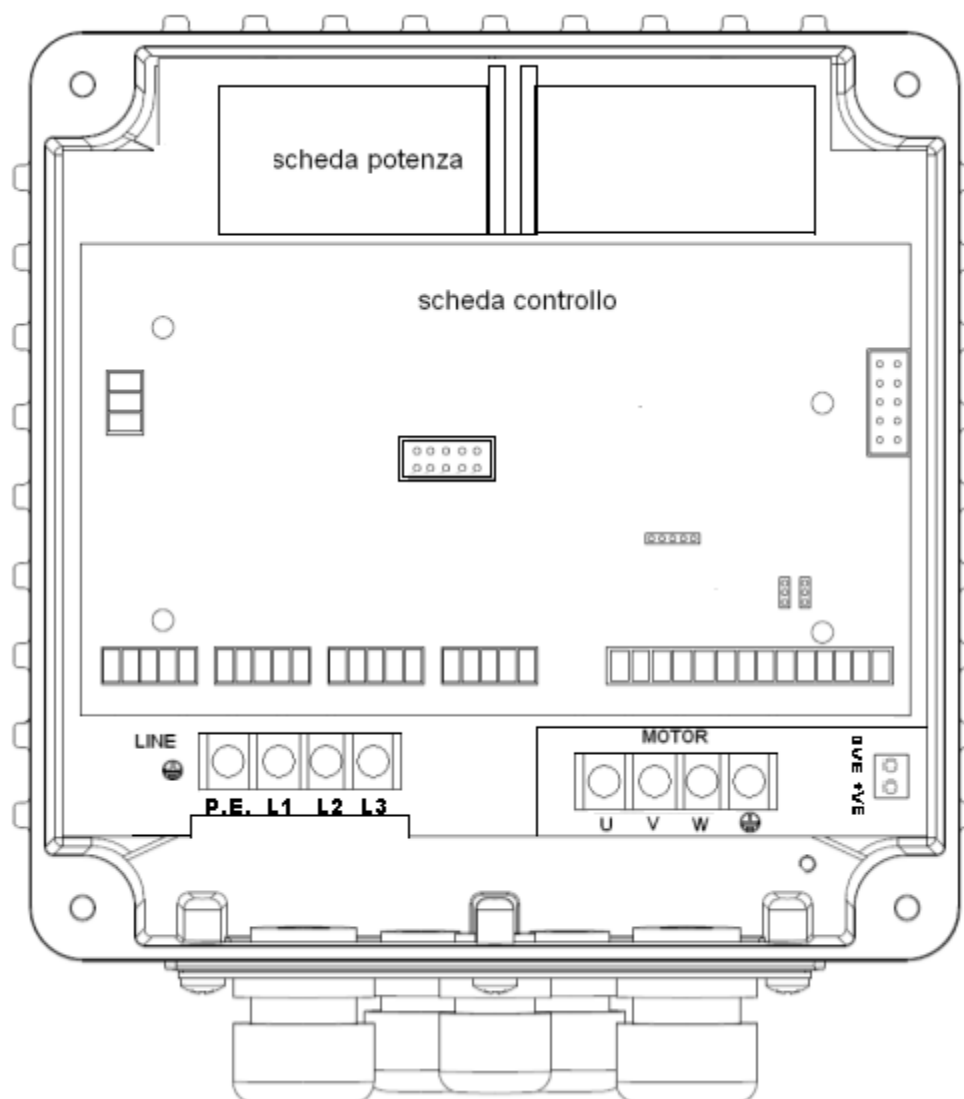

<p>Power supply: LINE: GND , L1, L2, L3, It is recommended to use cable lugs.</p>	<p>Motor output: MOTOR: U, V, W, GND It is recommended to use cable lugs.</p>	<p>12 V dc auxiliary fan (wall mounting kit) : 0VE, +VE WARNING: respect the polarity.</p>
--	--	--

Cable stripping recommended for line input and output to the motor.

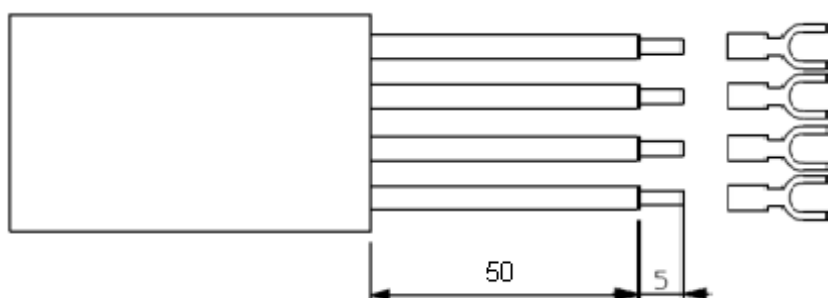

Power board VASCO 314,318,325,330,414,418,425,430

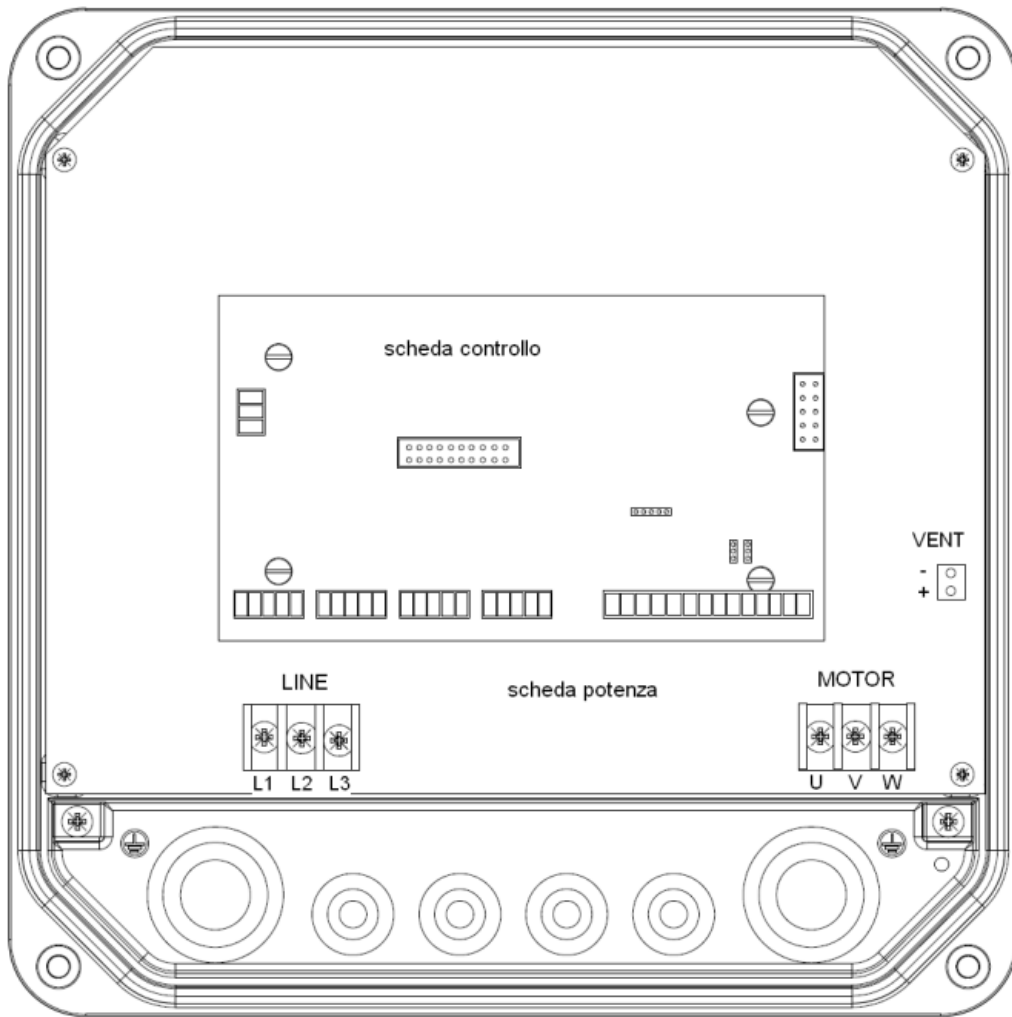

<p>Power supply: LINE: L1, L2, L3, GND It is recommended to use cable lugs.</p>	<p>Motor output: MOTOR: U, V, W, GND It is recommended to use cable lugs.</p>	<p>12 V dc auxiliary fans (wall mounting kit) VENT: +, - WARNING: respect the polarity.</p>
--	--	---

Cable stripping recommended for line input and output to the motor.

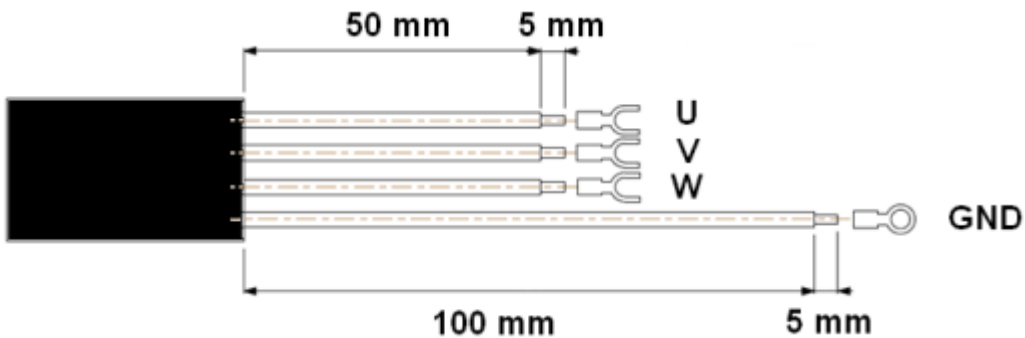

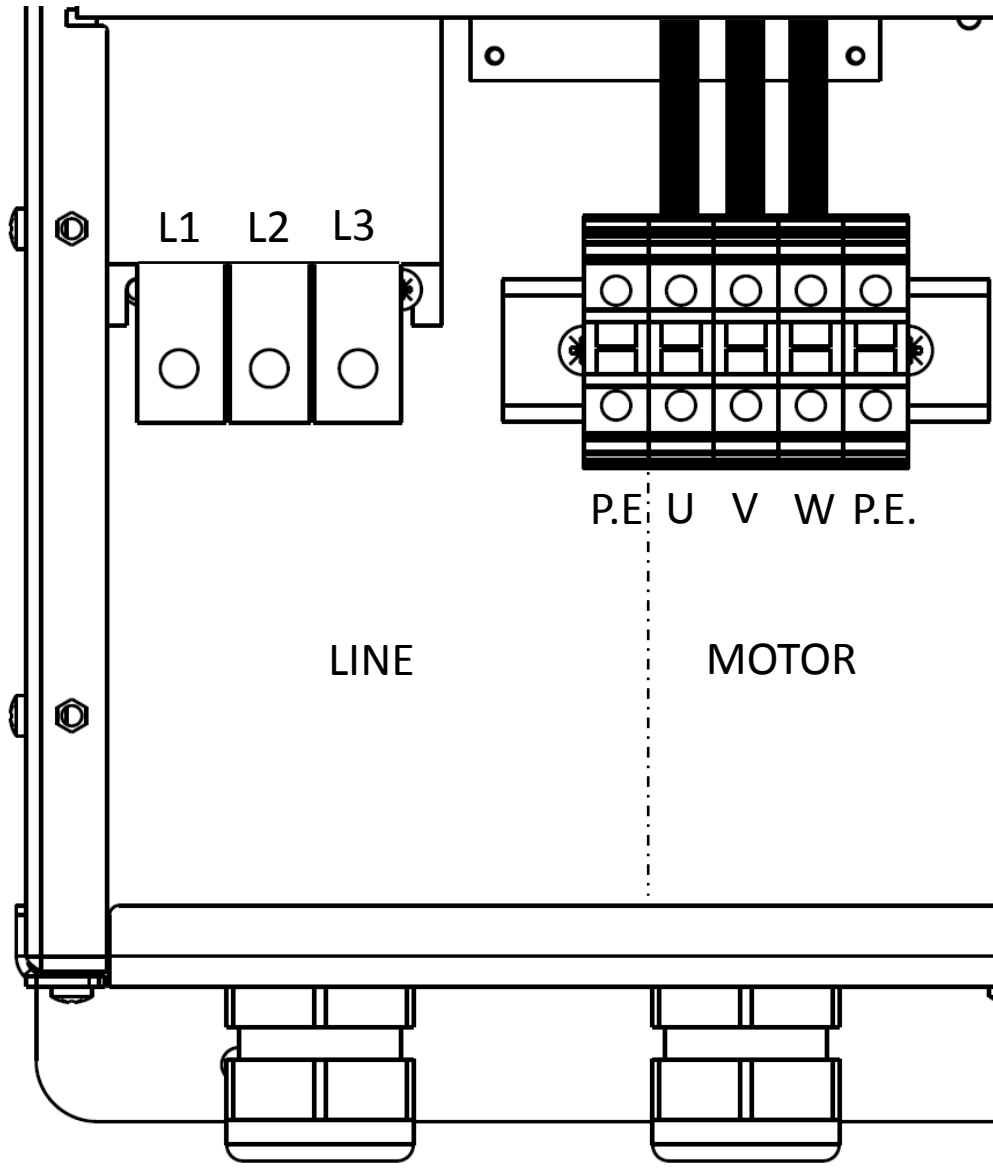

<p>Power supply:</p> <p>LINE: L1, L2, L3, P.E.</p> <p>It is recommended to use cable lugs.</p>	<p>Motor output:</p> <p>MOTOR: U, V, W, P.E.</p> <p>It is recommended to use cable lugs.</p>
---	---

Cable stripping recommended for line input and output to the motor.

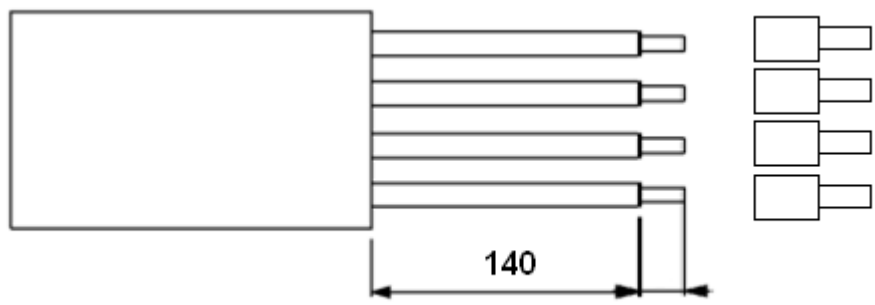

Control board

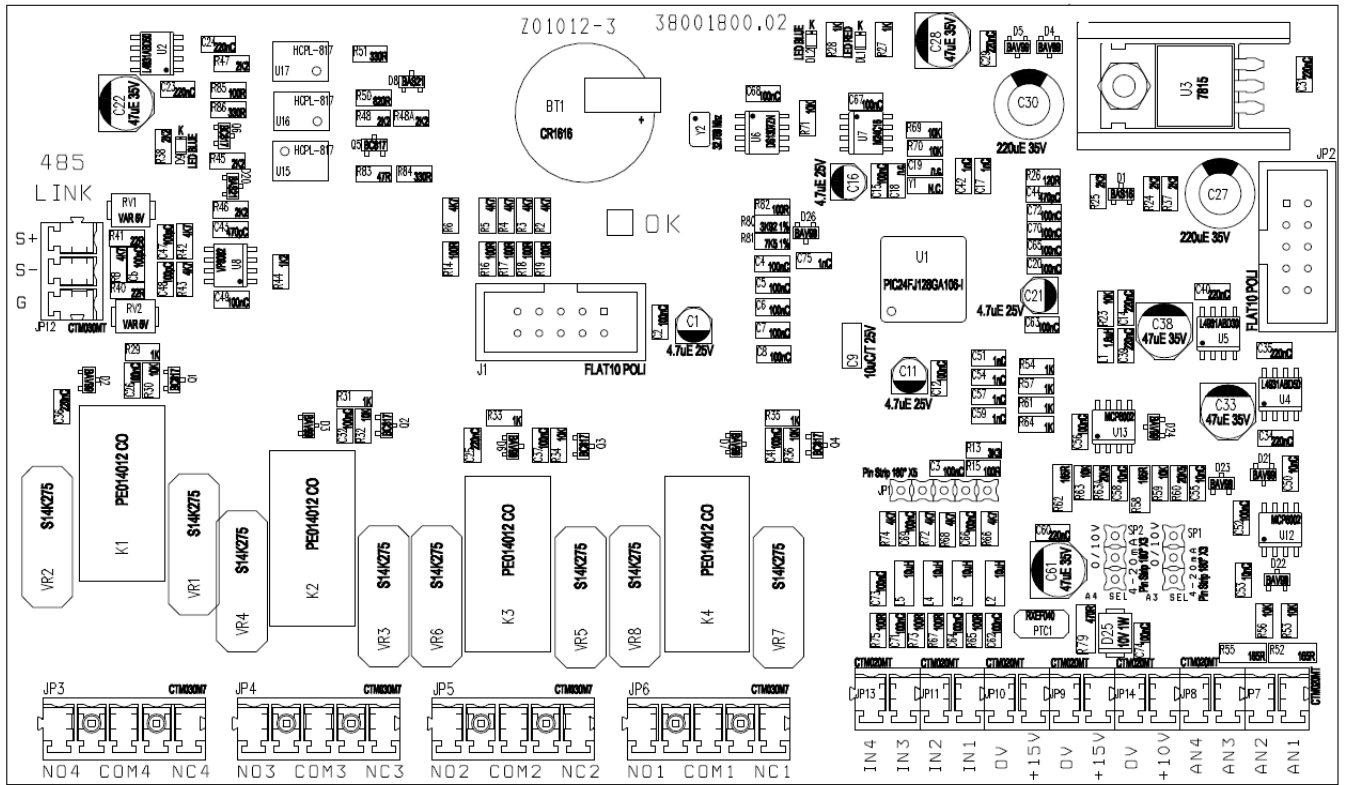

4.1 Protections

The protections required upstream each VASCOs depends on the type of installation, and local regulations. We recommend to use overload protection with the characteristic curve of type C and type B circuit breaker, sensitive to both AC and DC current.

4.2 Electromagnetic compliance

To ensure electromagnetic compatibility (EMC) of the system, it is necessary to apply the following measures:

- Always connect the device to ground
- Use shielded signal cables by placing the screen at one end.
- Use motor cable as short as possible (<1 m / <3 ft). For longer lengths, it is recommended to use shielded cables connecting the screen at both ends.
- Separate signal, motor, and power supply cables.

Note: To enable the restoration of the display screen when there are electromagnetic interference, VASCO periodically provides some fast "refresh" of the display.

4.3 Installation with long motor cables

With long motor cables it's recommended to decrease the commutation frequency from 10 kHz (default) to 2.5 kHz (advanced parameters). This reduces the probability of voltage spikes in the motor windings which may damage the insulation.

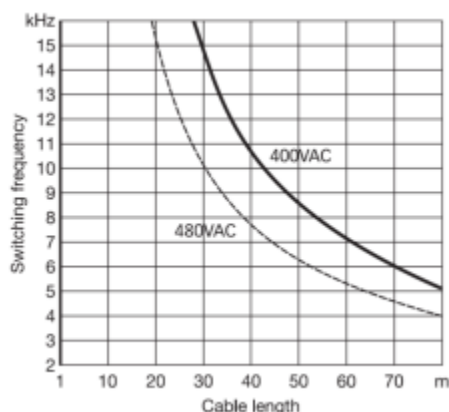

To prevent dangerous overheating of dv / dt and sinusoidal filters it is recommended to set the correct PWM value in relation to the cable length.

For motor cable lengths up to 50 meters it's recommended to place between VASCO and motor a dv / dt reactance, available on request.



For motor cable lengths greater than 50 meters it's recommended to place between VASCO and motor a sinusoidal filter, available on request.



5. VASCO installation

VASCO can be installed directly on the fan cover of the motor or mounted on the wall.

Motor mounting kit

In this application VASCO is cooled by the motor fan. Motor kit (available upon request) allows a solid coupling of the two units and it is composed of:

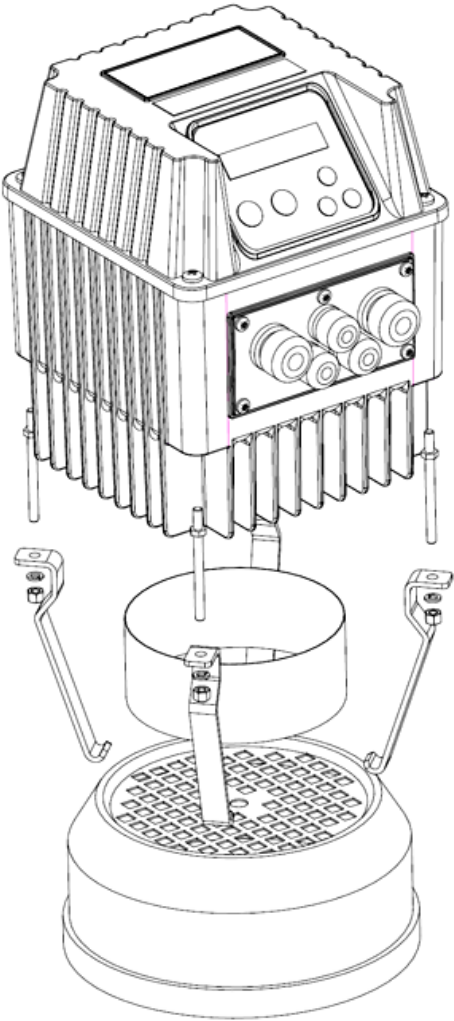
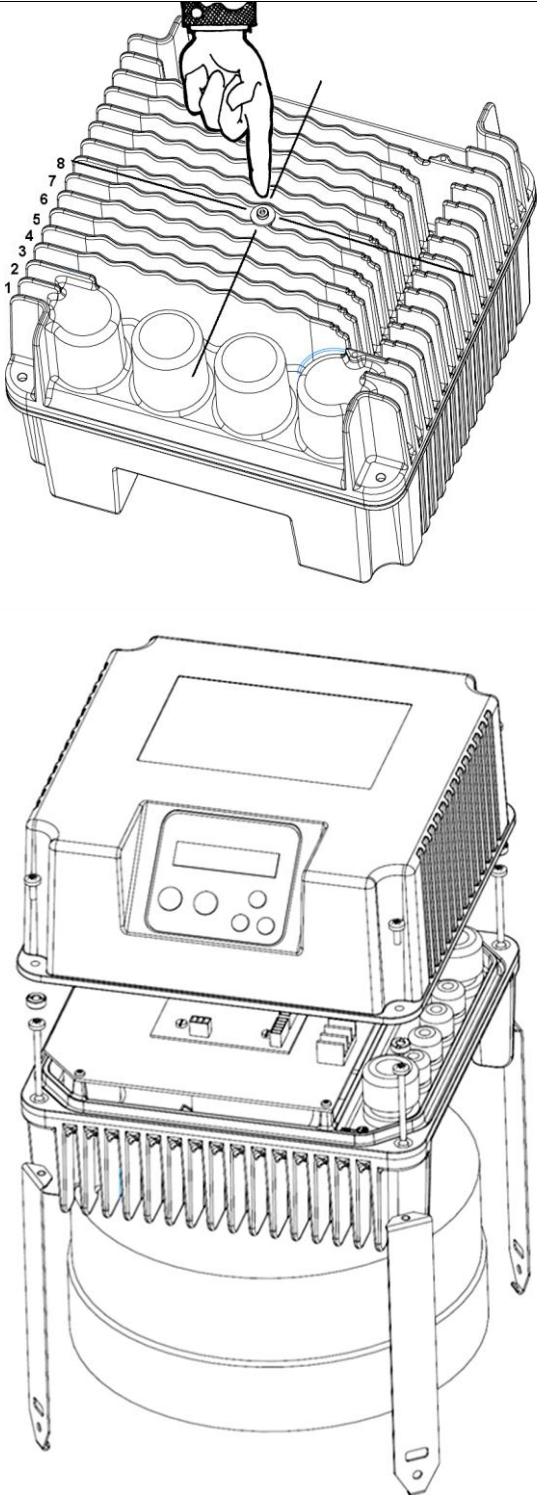
VASCO SIZE 1	VASCO SIZE 2
<ul style="list-style-type: none"> • n.°4 rods • n.°4 M5 nuts • n.° 4 hooks • n.° 1 cooling ring 	<ul style="list-style-type: none"> • n.° 4 M5 screws. • n.° 4 clamps • n.° 4 clips to add if necessary • n.°1 centre pin
 <p data-bbox="145 1653 756 1872">Use the cooling ring for best cooling of VASCO during operation. Warning: when using the cooling ring, the cooling air of the motor is slightly warmer than without the VASCO; if the resulting motor temperature exceeds the indicated maximum allowable value, remove the cooling ring, leaving the VASCO to be cooled by itself.</p>	

VASCO SIZE 3

- n.° 1 motor feet adaptor for MEC160,180,200,225
- n.° 4 M8 bolts,
- n.° 4 M10 bolts, nuts and washer

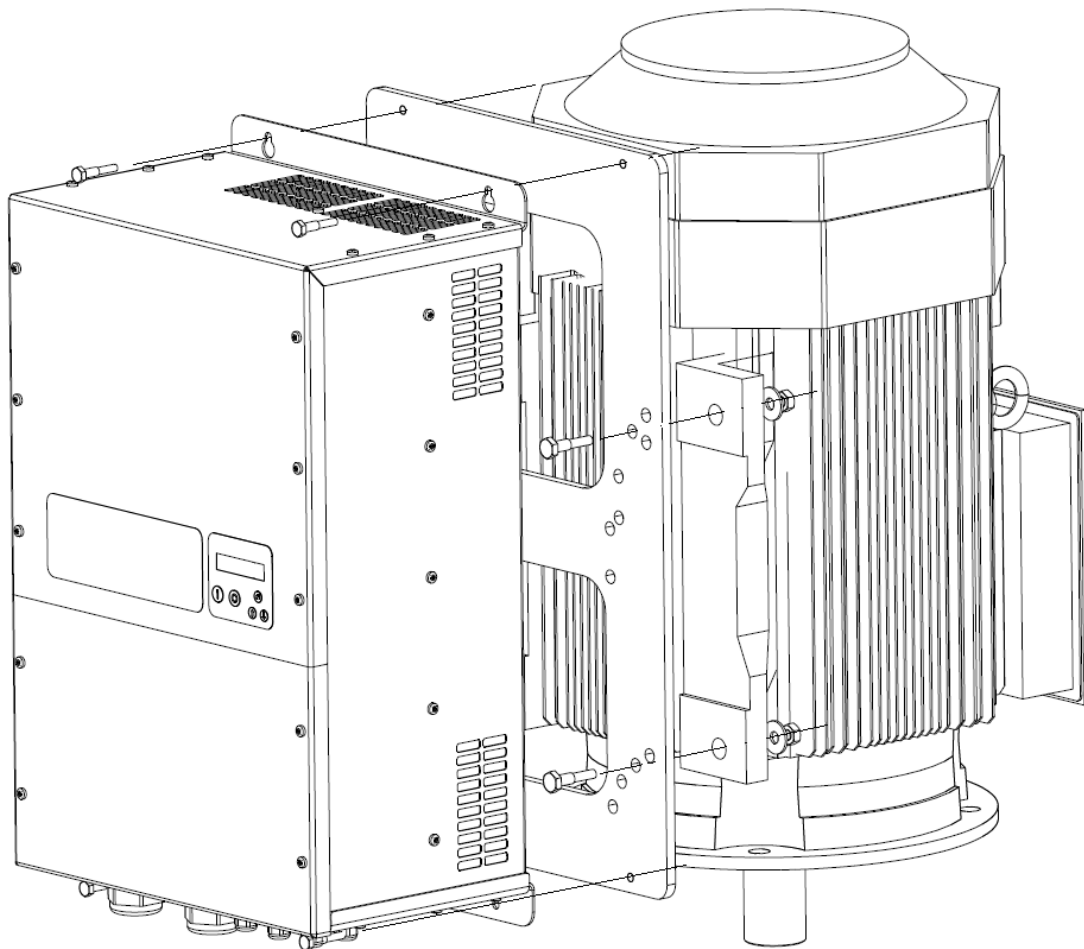

Wall mounting kit

In this application VASCO is cooled independently by its auxiliary cooling fan integrated in the radiator.

Wall-mounted kit is composed of:

VASCO SIZE 1	VASCO SIZE 2
<ul style="list-style-type: none"> • n.° 1 auxiliary fan 230V AC (VASCO 209,214) or 12 VDC (VASCO 306,309,406,409) • n.° 4 screws to fix cooling fan • n.° 1 protection grill • n.° 1 metal bracket in AISI 304 • n.° 4 screws to fix VASCO to wall bracket 	<ul style="list-style-type: none"> • n.° 2 12 V DC fans. • n.° 1 fans cover. • n.° 2 fans cover fixing screws • n.° 2 wall fixing brackets • n.° 4 M5 screws for VASCO fixing to the brackets • n.°1 holes reference sheet

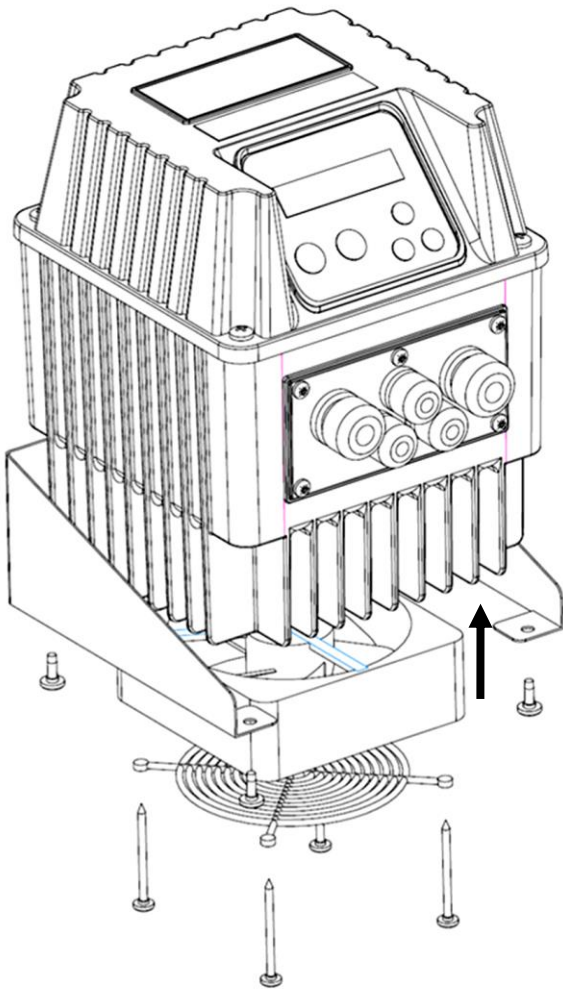

SCALE 1:1

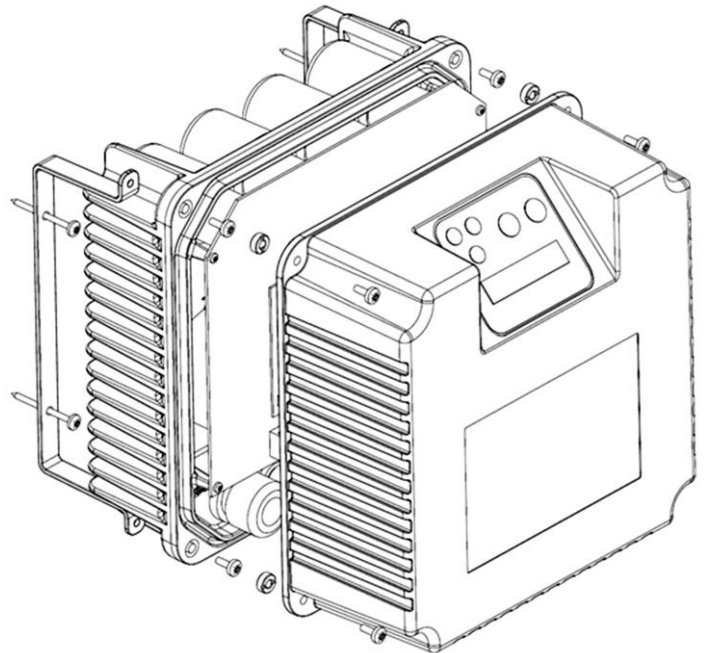
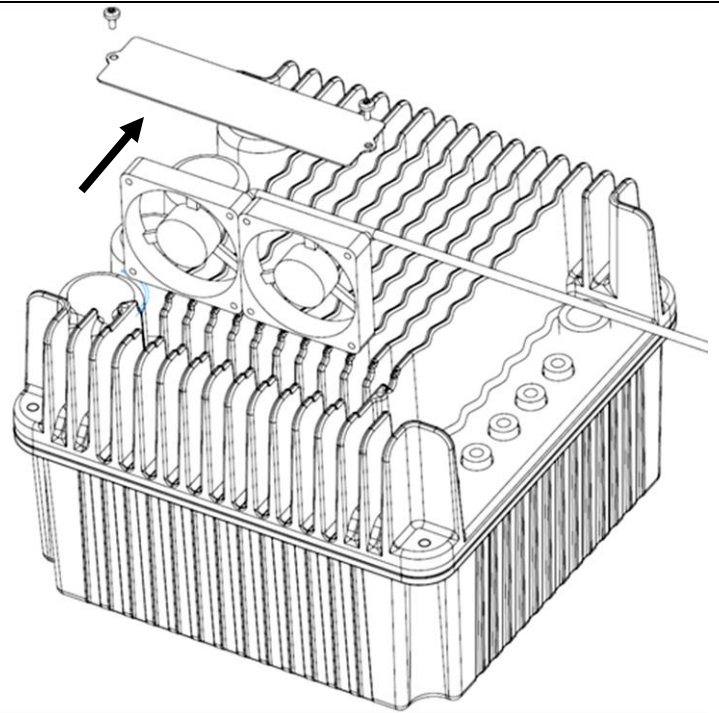

Make sure the manufacturer that the electric motor is suited for operation in the inverter
Make sure to properly attach the grid of the auxiliary cooling fan.
Make sure to remove the auxiliary cooling fan if VASCO is coupled to a motor. Failure to do so creates a high risk of overheating the motor and VASCO unit.

5.1 VASCO Installation for constant pressure control

VASCO controls the pump speed to maintain constant pressure at a set point independent of the water demand in the system. A basic schematic is shown below:

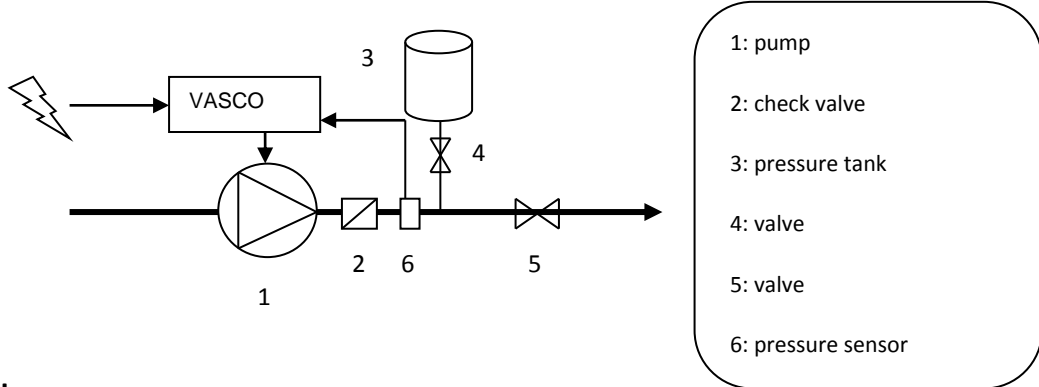

5.1.1 Pressure tank

Installation of a pressure tank in the hydraulic system is recommended to compensate leakage of water in the system (or during minimum water demand) and to avoid continuous start/stop cycling of the pump (check the appendix for more information). Selecting the proper volume and pre-charge pressure of the tank is very important; smaller tank volumes will not compensate adequately for minimum water usage or leakage, while larger volumes make it more difficult for VASCO to control the pressure evenly.

Recommended tank volume is equal to the 10% of the maximum water flow of the system (expressed in volume unit/min)

Example: if the max water flow is 50 liters/min, the pressure tank should have a capacity of 5 liters

If the max water flow is 20 gpm, the pressure tank should have a capacity of 2 gallons

Pre-charge pressure of the pressure tank should be at least 80% than the set-pressure of the system.

Example: if the set-pressure of the system is 4 bar, the pre-charge pressure of the tank should be 3.2 bar

If the set-pressure of the system is 60 psi, the pre-charge pressure of the tank should be 48 psi

5.1.2 Pressure sensor

VASCO requires a pressure sensor with a linear output signal within the range 4 – 20 mA. The pressure transducer can be powered by any range of DC Voltage which includes the value 15 V dc.

VASCO accepts the signal of a second pressure sensor in order to:

- realize constant differential pressure (AN1 – AN2).
- substitute first pressure sensor when it fails
- switch pressure sensor by closing digital input IN2

SENSOR 1	<ul style="list-style-type: none"> • AN1: 4-20 mA (-) signal • +15V: 15 Vdc (+) power supply
SENSOR 2	<ul style="list-style-type: none"> • AN2: 4-20 mA (-) signal • +15V: 15 Vdc (+) power supply

6. VASCO Use and Programming

VASCO software is extremely simple to use, but allows a wide variety of parameters to be set for ideal system calibration. Setting Parameters are organized in 2 levels:

1: Installer level

A password is required for this level; these parameters are adjustable by trained professionals

Default password: **001**

From the menu a different password can be set up.

2. Advanced level

A second and different password is required; improper setting of these advanced parameters could compromise the integrity and the life of VASCO and pump;

Default password **002**

It is possible to set up a different password.

Installer and Advanced levels can be entered only with the correct password; otherwise, it is impossible to set up and/or modify any parameters (they can be only displayed).

6.1 VASCO display

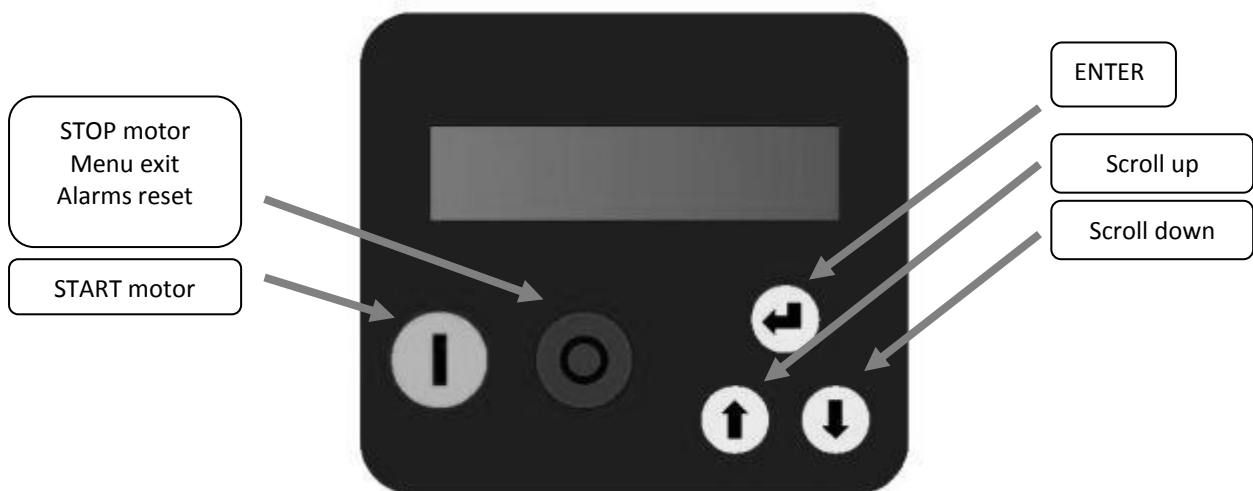

Screen is a back-lit LCD displaying 2 rows of 16 digits each. Alarms are indicated by an audible signal.

6.2 Initial configuration

When VASCO is switched on for the first time, the initial setting menu is displayed for the initial setting of parameters to configure pump characteristics, pressure sensor range, and system characteristics.

If the initial setting procedure is not completed properly, it is impossible to run the pump. Initial setting procedure can be repeated if necessary.

The initial setting procedure can be repeated (by using the 2nd level password) to reconfigure VASCO or if VASCO is installed in a different system.

A brief description of parameters and their allowable ranges are listed below:

Parameter	Default	Description
Language XXXXXX	XXXX	End user communication language
Unit XXXXX	bar	Unit
Motor type singlephase/threephase	threephase	Type of motor connected (VASCO 209,214)
Rated motor Amp. I = XX.X [A]	XX	Rated current of the motor per it's nameplate indication increased by 10%. The voltage drop caused by the inverter leads to higher input current than nominal. Make sure motor is capable of accepting increased current.
Rated motor freq f = XXX [Hz]	50	Rated frequency of the motor per its nameplate.
Control mode: Constant value [bar]		
F. scale sensor p = XX.X [bar]	16	Sensor full scale.
Sensor test Press ENT		If the transducer is not connected or connected improperly, the signal SENSOR OFF is activated when pressing ENTER.
Max alarm value p = XX.X [bar]	10	Maximum pressure allowed in the system. If the pressure goes over this value, an alarm occurs and the pump is stopped. Pump is automatically restarted if the pressure goes below the maximum value for a period of at least 5 seconds.
Motor test START/STOP		Press START/STOP to run a test at rated frequency Warning: make sure to run the system without damaging pump and system
Rotation sense ---> / <---	--->	If, during the test, the motor runs in reverse, it is possible to change the wiring sequence via software without physically changing wires at the terminals.
Set value p = XX.X [bar]	3	The pressure value to be kept constant.
Autorestart ON/OFF	OFF	If ON is selected, after a lack of voltage, VASCO returns to its normal status; if VASCO was powering the pump before the voltage drop, it resumes powering the pump automatically. <u>Warning</u> , review the advice in chapter 1
INITIAL SETUP COMPLETED		Once the Setting procedure is completed you will get this indication on the display; setting parameters are recorded by VASCO; these parameters can be set up individually in the INSTALLER Parameters menu or ADVANCED Parameters menu.

6.3 Initial view

When first powering the VASCO, the display shows : release of display software (LCD = X.XX) and the release of inverter software (INV = X.XX) as shown below:

LCD = X.XX
INV = X.XX

The following End User messages are displayed by pushing the scroll buttons:

<p>Inv: ON/OFF Mot: ON/OFF p = XX.X [bar]</p>	<p><i>p</i> is the pressure value read by the pressure transducer. By pressing ENTER the pressure set value is displayed <XXX.X></p>
<p>Inv: ON/OFF Mot: ON/OFF f = XXX [Hz]</p>	<p>f value is the supply frequency to the motor; On fix frequency control mode, by pressing ENTER you can change the f value manually (word "set" is displayed) , press ENTER again to exit parameter setting (word "set" disappeared).</p>
<p>Inv: ON/OFF Mot: ON/OFF V_in = X.XX [V] I= XX.X</p>	<p>V_in is the line voltage. This value is displayed only if motor is OFF; if motor is ON, A value equal to the absorbed motor current.</p>
<p>Inv: ON/OFF Mot: ON/OFF cosphi = XXX</p>	<p>cosphi index means the angle phi between the voltage and current absorbed by the motor</p>
<p>Inv: ON/OFF Mot: ON/OFF P = XXXXX [W]</p>	<p>P is the power in Watts supplied to the pump.</p>
<p>Inv: ON/OFF Mot: ON/OFF STATUS: NORMAL</p> <hr/> <p>Inverter Life xxxxx h : xx m</p> <hr/> <p>Motor Life xxxxx h : xx m</p> <hr/> <p>%f 25 50 75 100 %h XX XX XX XX</p> <hr/> <p>XXXXXXXXXXXXXXXXXX XXXXXXXXX h : XX m</p>	<p>NORMAL status means no alarms. If an alarm occurs, a message blinks on the display and an audible signal is activated. Pressing ENTER accesses: VASCO lifetime, PUMP lifetime, consumption statistic, alarm list. To return to previous views, press ENTER.</p>
<p>Menù ENT to access</p>	

First row gives the VASCO status:

- **Inv: ON XXX.X Hz** VASCO is powered and is powering the motor showing its frequency.

- **Inv: ON Mot: OFF** VASCO is powered but motor is not running (i.e. motor/pump was stopped due to minimum frequency being reached)
- **Inv: OFF Mot: OFF** VASCO is not powered

If COMBO function is activated, the VASCO address is placed close to indication “Inv”.

6.4 Menu view

Pressing ENTER when you are in [MENU' / ENT to access] in initial display, will display the following MENUS:

MENU' Install. param.	Installer password required to enter level 1 (default 001)
MENU' Advanced. param.	Advanced password required to enter level 2 (default 002)
MENU' Retrive init.set	Installer password required to enter level 1 (default 001) It is possible to return to original set parameters.
MENU' Change init.set.	Advanced password required to enter level 2 (default 002)

To exit the Menu level and return to initial display, press STOP button.

6.5 Installer parameters

Many of the Installer parameters are set during the Initial Configuration (*chapter 6.2 Initial Configuration*).

However, through the Installer Parameters menu, it is possible to change the set parameters or set others in order to perfect the calibration of VASCO to the pumping system.

parameter	default	description	Constant value	Fix speed	Const.value 2 set	Fix speed 2 val.	External speed
<div style="border: 1px solid black; padding: 5px; width: fit-content;"> Control mode <ul style="list-style-type: none"> • Constant value • Fix speed • Const.value 2set • Fix speed 2 val. • External speed </div>	Constant value	Mode of control: <ul style="list-style-type: none"> • Constant value: VASCO changes the speed of pump to keep the set value constant, independent of water demand. • Fix speed: VASCO feeds the pump a set frequency, so the speed of motor is kept constant. • Const. value 2 set: the two values are selected by opening or closing the digital input IN2. • Fix speed 2 val: to be selected by opening or closing the digital input IN2. • External speed: control motor frequency by using analogical input AN4. 					
Unit XXXXX	bar	Unit	✓	✓	✓	✓	✓

parameter		default	description	Constant value	Fix speed	Const.value 2 set	Fix speed 2 val.	External speed
F. scale sensor p = XX.X [bar]		16	Sensor full scale.	✓	✓	✓	✓	✓
Min value sensor p = XX.X [bar]		0	Sensor minimum value.	✓	✓	✓	✓	✓
Max alarm value p = XX.X [bar]		10	Maximum value allowed in the system. If the readen value goes over this value, an alarm occurs and the pump is stopped. Pump is automatically restarted if the readen value goes below the maximum value for a period of at least 5 seconds.	✓	✓	✓	✓	✓
Min alarm value p = XX.X [bar]		0	Minimum value allowed in the system. If the readen value goes lower than this value, an alarm occurs and the pump is stopped. Pump is automatically restarted if the readen value goes higher than the minimum value for a period of at least 5 seconds.	✓	✓	✓	✓	✓
Ext.set enabling ON/OFF		OFF	Enabling of set value changing by analog input AN3.	✓		✓		
Set value p = XX.X [bar]		3	The set value to be kept constant.	✓				
Compensation p = XX.X [bar]		0	Value compensation at the maximum frequency for each pump. Acting on the green button you can reverse the sign.	✓				
Set value 2 p = XX.X [bar]		3	The set value to be kept constant.			✓		
Compensation 2 p = XX.X [bar]		0	Value compensation at the maximum frequency for each pump. Acting on the green button you can reverse the sign.			✓		
Set value update t = XX [s]		5	Time to update set value for compensation.	✓		✓		

parameter	default	description	Constant value	Fix speed	Const.value 2 set	Fix speed 2 val.	External speed
-----------	---------	-------------	----------------	-----------	-------------------	------------------	----------------

To ensure proper operation of pressure control is recommended to place the sensor near the pump.
 To compensate the pressure loss in the pipes (proportional to flow) it is possible to vary the pressure set in a linear relation with respect to frequency.

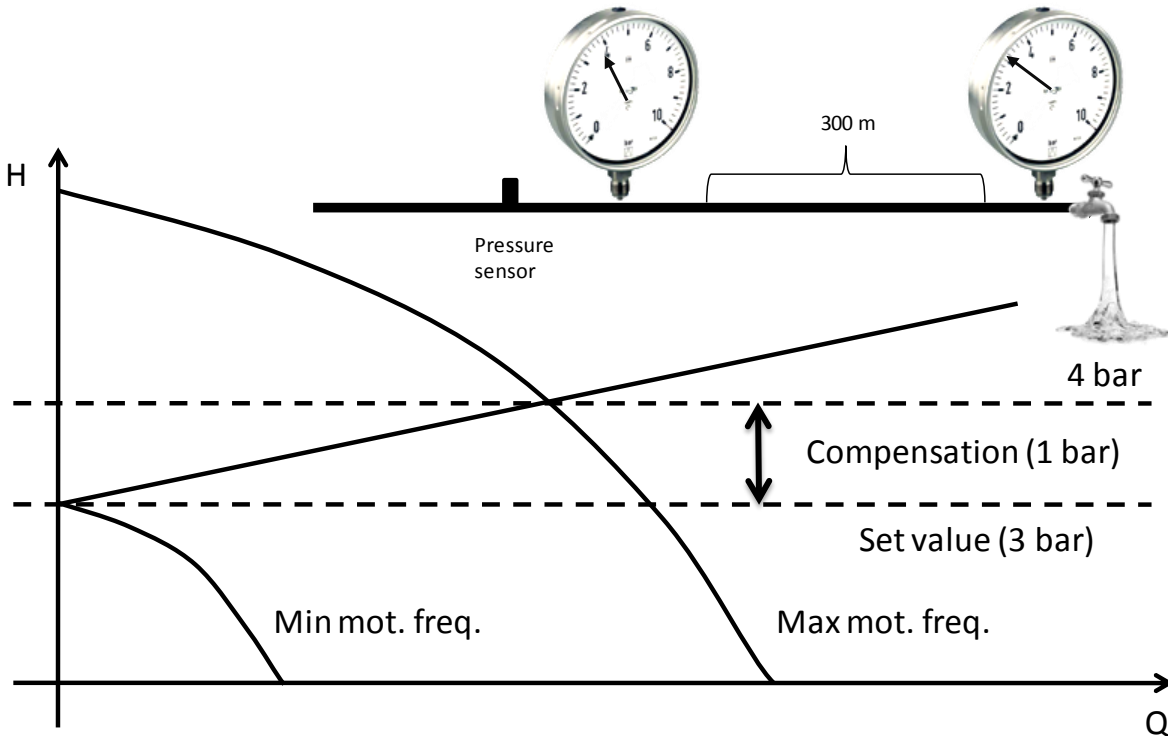

It can perform the following test to verify the correct value of compensation:

1. install a pressure gauge away from the pressure sensor
2. open completely the valve
3. check the pressure gauge

--> Set the value of *compensation*. equal to the difference of the values from the two gauges.

When using a group of pumps, the pressure compensation to be applied to each pump is equal to the total pressure compensation (when all the pumps are running at full speed) divided by the number of pumps in the group.

Operating freq. f = XXX [Hz]	50	Set the frequency value to feed the pump.		✓			
Operating freq. 2 f = XXX [Hz]	50	Set the frequency value to feed the pump.				✓	
Freq.min.control fmin = XXX [Hz]	50	Minimum frequency below which the pump tries to stop.	✓		✓		✓
Stop delay t = XX [s]	5	Delay for which the pump tries to stop below freq.min. control.	✓		✓		✓
Control ramp t = XX [s]	20	Ramp time from freq.min.control to min.motor freq. If, during this time, the readen value goes below the (set value - delta control), VASCO powers the motor again; otherwise, VASCO will stop the	✓		✓		✓

parameter		default	description	Constant value	Fix speed	Const.value 2 set	Fix speed 2 val.	External speed
			pump.					
Delta control p = XX.X [bar]		0.1	This value represents the value drop below the set value required to restart the pump during control ramp.	✓		✓		
Delta start p = XX.X [bar]		0.5	This value represents the value drop below the set value required to start the pump from stop condition.	✓		✓		
Delta stop p = XX.X [bar]		0.5	It's the value increase respect to set value which must be passed so that there is a forced shutdown of the pump.	✓		✓		
Ki XXX			Kp and Ki parameters allow the dynamic control of system by VASCO; set values (Ki=50, Kp=005) are usually enough to get a valid dynamic control.	✓		✓		
Kp XXX								
Pump DOL 1 ON/OFF		OFF	Function to activate (ON) the first auxiliary pump DOL 1 (Direct On Line pump).	✓		✓		
Pump DOL 2 ON/OFF		OFF	Function to activate (ON) the second auxiliary pump DOL 2 (Direct On Line pump).	✓		✓		
Alternance ON/OFF		OFF	Function to allow alternating starting priority between the DOL pumps in order to allow equal use of them.	✓		✓		

parameter	default	description	Constant value	Fix speed	Const.value 2 set	Fix speed 2 val.	External speed
Start delay AUX t = XX [s]	1	delay time with which the pumps DOL start after the variable speed pump has reached the maximum frequency and the readen value has fallen below set value – delta control.	✓		✓		
COMBO ON/OFF	OFF	Function to enable multiple VASCO's to work in parallel as described in the technical appendix (see the relevant chapter). Up to 8 VASCO units can be connected in parallel. VASCO's communication through RS 485 gates is granted by a private protocol.	✓		✓		
PI control Direct/Reverse	Direct	Direct: increasing misured value, VASCO decreases motor frequency. Reverse: increasing misured value, VASCO increase motor frequency.	✓		✓		
Rotation sense ---> / <---	--->	If, during the test, the motor runs in reverse, it is possible to change the wiring sequence via software without physically changing wires at the terminals.	✓	✓	✓	✓	✓
Dry run cosphi cosphi = X.XX	0.65	If the pump goes into dry-running, the cosphi reaches its lowest level. To set this value, contact the pump manufacturer or test by closing the suction and checking the value on the VASCO display; a value can be set by assuming a dry cosphi equivalent to 60% of the rated cosphi specified by the manufacturer.	✓	✓	✓	✓	✓
Restarts delay t = XX [min]	10	Restart delay after a dry running alarm. At each tentative (max 5) restart delay will be doubled.	✓	✓	✓	✓	✓
Digital input 1 N.O. / N.C.	N.O.	By selecting N.A. (normally open) VASCO runs the motor if the digital input 1 is open; motor will be stopped if the digital input 1 is closed. By selecting N.C. (normally closed) VASCO runs the motor if the digital input 1 is closed; motor will be stopped if the digital input 1 is opened.	✓	✓	✓	✓	✓
Digital input 2 N.O. / N.C.	N.O.	By selecting N.A. (normally open) VASCO runs the motor if the digital input 2 is open; motor will be stopped if the digital input 2 is closed. By selecting N.C. (normally closed) VASCO runs the motor if the digital input 2 is closed; motor will be stopped if the digital input 2 is opened.	✓	✓	✓	✓	✓
Digital input 3 N.O. / N.C.	N.O.	By selecting N.A. (normally open) VASCO runs the motor if the digital input 3 is open; motor will be stopped if the digital input 3 is closed. By selecting N.C. (normally closed)	✓	✓	✓	✓	✓

parameter	default	description	Constant value	Fix speed	Const.value 2 set	Fix speed 2 val.	External speed
		VASCO runs the motor if the digital input 3 is closed; motor will be stopped if the digital input 3 is opened.					
<div style="border: 1px solid black; padding: 5px; width: fit-content; margin: 0 auto;"> Digital input 4 N.O. / N.C. </div>	N.O.	By selecting N.A. (normally open) VASCO runs the motor if the digital input 4 is open; motor will be stopped if the digital input 4 is closed. By selecting N.C. (normally closed) VASCO runs the motor if the digital input 4 is closed; motor will be stopped if the digital input 4 is opened.	✓	✓	✓	✓	✓
<div style="border: 1px solid black; padding: 5px; width: fit-content; margin: 0 auto;"> Dig.In.2/3 delay t= XX [s] </div>	3	Digital input IN2 and IN3 delay. Digital input IN1 and IN4 have 1 second fix delay.	✓	✓	✓	✓	✓
<div style="border: 1px solid black; padding: 5px; width: fit-content; margin: 0 auto;"> Change PASSWORD1 ENT </div>		Pressing ENT allows the installer level password (1st level) (default 001) to be changed.	✓	✓	✓	✓	✓

6.6 Advanced parameters

All the advanced parameters, due to their importance, are already set during initial setup (*cap. 6.2 Initial Configuration*). However, it is always possible to modify individual parameters or modify the password 2:

Parameters	Default	Description
<div style="border: 1px solid black; padding: 5px; width: fit-content; margin: 0 auto;"> Rated motor Volt. V = XXX [V] </div>	XXX	Motor rated voltage (as shown in the motor plate) Average voltage drop due to the inverter is between 20 V and 30 Vrms based on load condition.
<div style="border: 1px solid black; padding: 5px; width: fit-content; margin: 0 auto;"> Voltage boost V = XX [%] </div>	1%	Refers to the voltage increase during the start up of the motor. Warning: An excessive value can seriously damage the motor. Contact the motor manufacturer for further information. If a single-phase motor is used, a value of 1% is suggested to increase the starting torque.
<div style="border: 1px solid black; padding: 5px; width: fit-content; margin: 0 auto;"> Rated motor Amp. I = XX.X [A] </div>	XX	Rated current of the motor per it's nameplate indication increased by 10%. The voltage drop caused by the inverter leads to higher input current than nominal. Make sure motor is capable of accepting increased current.
<div style="border: 1px solid black; padding: 5px; width: fit-content; margin: 0 auto;"> Rated motor freq f = XXX [Hz] </div>	50	Rated frequency of the motor per its nameplate.
<div style="border: 1px solid black; padding: 5px; width: fit-content; margin: 0 auto;"> Max motor freq. f = XXX [Hz] </div>	50	Maximum frequency of the motor. Note: by reducing the maximum frequency of the motor, maximum current will be reduced as well.

<div style="border: 1px solid black; padding: 5px; width: fit-content;"> Min motor freq. f = XXX [Hz] </div>	30	Minimum frequency of the motor. Note: depends on the selected pump type; for submersible pumps with water filled motors, is not advisable to set minimum frequency lower than 30 Hz in order to protect the integrity of the thrust bearings.
<div style="border: 1px solid black; padding: 5px; width: fit-content;"> Ramp up time t = XX [sec] </div>	4	Ramp-up time to reach the speed required to achieve the set pressure (or frequency value). Longer times delay the system reaching the preset value but better protect system components. Excessively long ramp-up times can create difficulties in VASCO setup, and can also cause false overload alarms.
<div style="border: 1px solid black; padding: 5px; width: fit-content;"> Ramp down time t = XX [sec] </div>	4	Ramp-down time to reach zero speed. Longer times keep the system pressurized, while protecting the system components. Excessively long ramp-down times can create difficulties in VASCO setup. Excessively short ramp-down times can cause false overload alarms.
<div style="border: 1px solid black; padding: 5px; width: fit-content;"> Ramp f min mot. t = XX [sec] </div>	1.5	Time to reach the minimum frequency of the motor and vice versa. When VASCO is used to control a water filled submersible motor it's important to keep this time at 1 second.

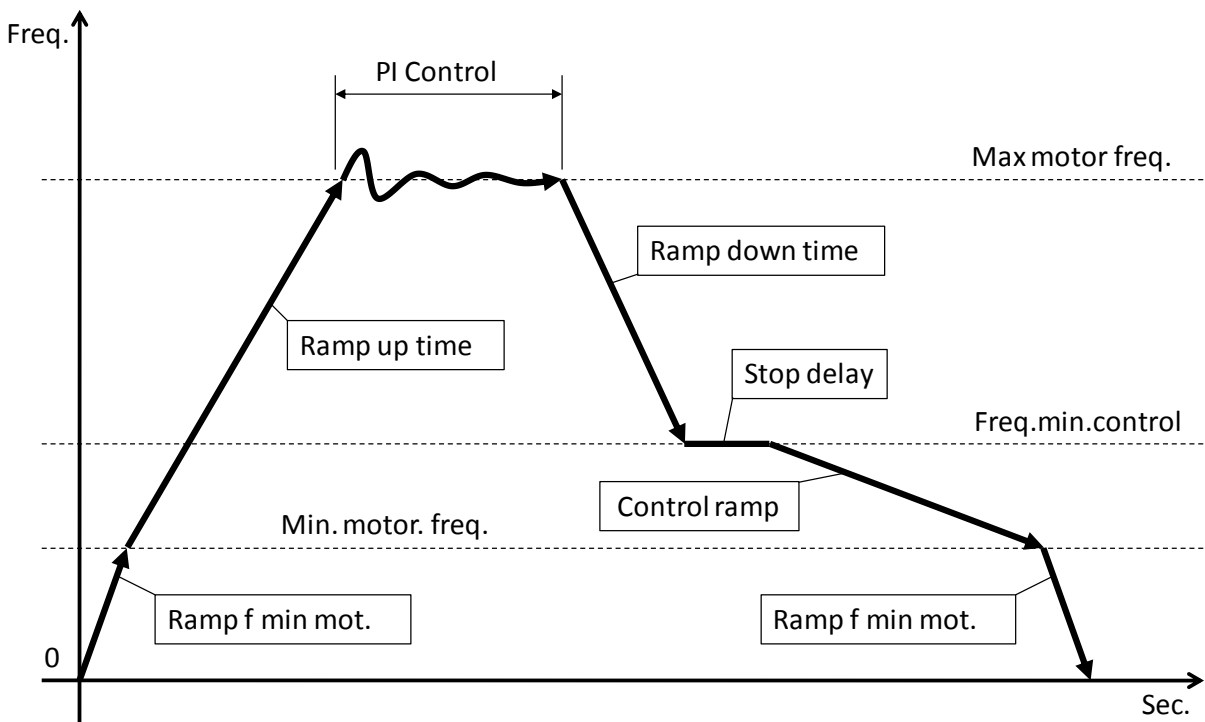

<div style="border: 1px solid black; padding: 5px; width: fit-content;"> PWM f = XX [kHz] </div>	8	Carrier frequency (switching frequency). It is possible to chose PWM in the range of 2.5 ,4, 6, 8, 10 kHz . Higher values give a more sinusoidal wave with fewer losses. If long cables are used (>20 m / >76 ft) (submersible pump) it is recommended to install an inductive filter between VASCO and the motor (available upon request) and to set the value of PWM to 2.5 kHz. This reduces the risk of voltage spikes, which can damage motor and cable insulation.
<div style="border: 1px solid black; padding: 5px; width: fit-content;"> V/f lin. --> quad. XXX % </div>	85 %	This parameter allows you to change the V / f characteristic with which VASCO feeds the engine. The linear characteristic corresponds to constant torque with variable speed. The quadratic characteristic is normally used with centrifugal pumps. The selection of torque characteristic should be done ensuring a smooth operation, a reduction of energy consumption and a lower level of heat and acoustic noise. When feeding singlephase motors it's suggested to set V/f as linear (0%).

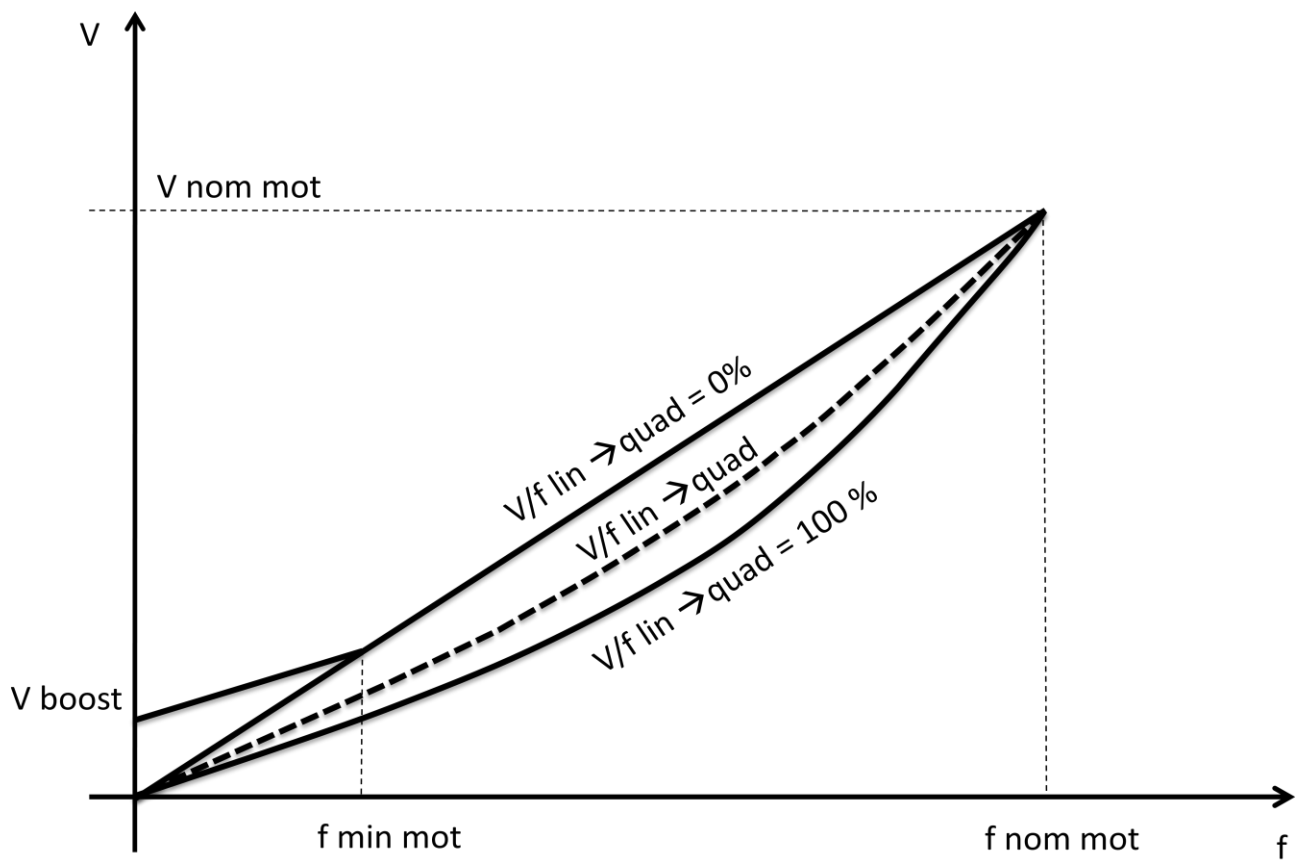

Autorestart ON/OFF	OFF	If ON is selected, after a lack of voltage, VASCO returns to its normal status; if VASCO was powering the pump before the voltage drop, it resumes powering the pump automatically. <u>Warning</u> , review the advice in chapter 1.
Periodic autorun t = XX [h]	0	Pump periodic autorun after XX hours of inactivity. Value 0 makes function disabled. <u>Warning</u> , review the advice in chapter 1.
AN1,AN2 function XXXXXX	Indipendent	Function logic for analog input AN1,AN2.
Offset input 1 x = XX.X [%]	20%	Zero correction for analog input 1 (20 mA x 20% = 4 mA).
Offset input 2 x = XX.X [%]	20%	Zero correction for analog input 2 (20 mA x 20% = 4 mA).
Offset input 3 x = XX.X [%]	20%	Zero correction for analog input 3 (20 mA x 20% = 4 mA).
Offset input 4 x = XX.X [%]	00%	Zero correction for analog input 4 (default 0-10V) (10V x 00% = 0 V).
Change PASSWORD2 ENT		Pressing ENT allows the advanced level password (2st level) (default 002) to be changed.

7. Protections and alarms

Anytime a protection occurs a blinking message is displayed together with an audible alarm; on STATUS in the initial view, the protection is displayed; by pressing the STOP button. Only from this position (STATUS) in the initial view is it possible to try to reset the alarm; if VASCO does not reset the alarm it is displayed again together an audible sound.

ALARM MESSAGE	ALARM DESCRIPTION	POSSIBLE SOLUTIONS
OVERCURRENT MOT.	<p>Motor overload: input current of the motor is higher than the rated motor current setting parameter.</p> <p>Motor voltage drop caused by the inverter causes the motor input current to be higher than rated. Contact motor manufacturer to check if motor is capable of accepting this current.</p>	<ul style="list-style-type: none"> • Make sure that the motor current setting parameter is higher than rated. • Check other possible causes of over current
UNDER VOLTAGE	Supply voltage too low	Check possible causes of undervoltage
OVER VOLTAGE	Supply voltage too high	Check possible causes of overvoltage
OVER TEMP. INV.	Inverter over temperature	<ul style="list-style-type: none"> • Make sure than ambient temperature is less than 40 °C (104 °F). • Check if auxiliary cooling fan is working properly and if mounting space is adequate for proper cooling. • Reduce the PWM value (<i>Advance Parameter Menu</i>)
NO LOAD	No load	<ul style="list-style-type: none"> • Check if load is properly connected to the VASCO terminals
NO WATER (DRY RUN COSPHI)	Motor cosphi is lower than the set value of dry running cosphi	<ul style="list-style-type: none"> • Check if the pump is primed • Check the set value of dry running cosphi. Dry running cosphi is approximately 60% of the rated cosphi (at rated frequency) listed on the motor plate. <p>If pump's cosphi is lower than the set dry-running cosphi for at least 2 seconds, VASCO stops the pump. VASCO tries to run the pump every 10, 20, 40, 80, 160 minutes and then the pump is stopped.</p> <p>WARNING: if dry running protection occurs, VASCO will try to start the pump automatically. Be sure to cut power supply to VASCO before performing any maintenance.</p>
SENSOR FAULT	Sensor error	<ul style="list-style-type: none"> • Check the transducer • Check the wiring of transducer
MAX. VALUE ALARM	Measured value has reached the maximum value accepted by the system.	<ul style="list-style-type: none"> • Check possible causes of reaching max value • Check the max alarm value setting
MIN. VALUE ALARM	Measured value has reached the lowest	<ul style="list-style-type: none"> • Check possible causes reaching min value

	value accepted by the system.	(i.e. broken pipe, open pressure relief valve, etc.) <ul style="list-style-type: none"> • Check the min alarm value setting.
IGBT TRIP ALARM	The current drawn by the load exceeds the capacity of VASCO. VASCO is still able to continue to power the load for 10 minutes with an output current of 101% of nominal and for 1 minute with an output current of 110% of nominal	<ul style="list-style-type: none"> • Increase the ramp-up time • Make sure that the load current is at least 10% below the VASCO nominal current • Check the voltage drop along the supply cable to the motor
NO COMMUNICATION	Communication between Master and slave(s) has been interrupted	<ul style="list-style-type: none"> • Check the wiring connections • Make sure the Master is not in the Menu level; if so, exit from the level. • In the STATUS of the slave (where the alarm is displayed) try to reset the alarm by pushing STOP button.
ADDRESS ERROR	Same address as other VASCOS in the group	<ul style="list-style-type: none"> • The address of each VASCO needs to be different
KEYBOARD FAULT	A Button on the keyboard has been pressed for more than 150 seconds	<ul style="list-style-type: none"> • Make sure buttons are not depressed • Call service assistance
ACTIVE DIG.IN.X	Digital input X opened /closed	<ul style="list-style-type: none"> • Check the input digital configuration (Installer Parameters menu)
ALARM SLAVE XX	slave XX error detected by master	<ul style="list-style-type: none"> • check the status of the slave
	<p>If pumps cosphi is lower than the dry-running cosphi for at least 2 seconds, VASCO will stop the pump. VASCO will try to run the pump every 10, 20, 40, 80, 160 minutes and then the pump is stopped.</p> <p>ATTENTION: if dry-running protection occurs, VASCO will try to start the pump automatically. Be sure to cut power supply before attempting maintenance</p> <p>VASCO will stop the pump if the input motor current is higher than the set motor current for an extended time. By pressing the START button it is possible to run the pump again.</p> <p>VASCO will stop the pump if the input voltage is higher than the set voltage for an extended time. By pressing the START button it is possible to run the pump again. VASCO will stop the pump if the input voltage is lower than the set voltage for an extended time. By pressing the START button it is possible to run the pump again.</p>	

8. Auxiliary pumps during constant pressure control

When the water needs vary considerably, it is advisable to share the water request between several pumps ensuring better efficiency and reliability.

A first method consists of a single pump driven directly by VASCO and another 1 or 2 pumps directly connected to the mains DOL (Direct On Line); DOL pumps are controlled by VASCO and connected to the mains through 1 or 2 contactors.

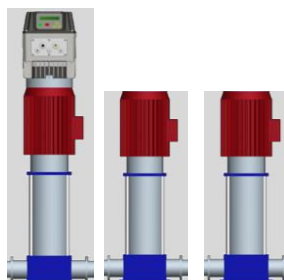

In this method, DOL pumps are not started and stopped smoothly with the corresponding increase in energy consumption and mechanical wear (startup current). Also note that DOL pumps are not protected by VASCO.

A second method of sharing water demand (named COMBO mode) consists of using additional pumps in parallel (up to 8), with each one driven by a VASCO.

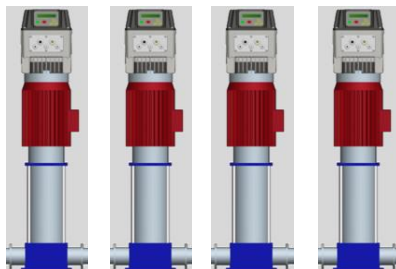

In this method, energy consumption and reliability of the pumping system is maximized: VASCO monitors and protects each pump. It is possible to assemble a booster system composed of pumps connected in COMBO mode and another 1 or 2 DOL pumps to cover additional water demand (managed only by master).

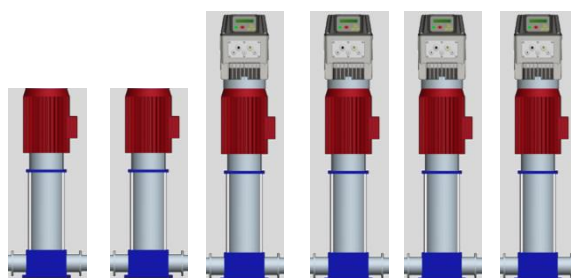

8.1 DOL pumps

Each DOL pump is switched on by a contactor controlled by the digital output DOL1 and DOL2 present in the VASCO.



VASCO relays driving the DOL pumps are relays with no voltage contacts. Max voltage to the contacts is 250 V, max current 5 A.

Two pumps are connected in parallel, with one pump (pump 1, P1) run by the inverter, while the second pump (pump 2, P2) is directly connected to the main power ("Direct On Line" connection). Start/Run of the second pump is controlled by the relay DOL1 (allowing a third pump to be controlled by the relay DOL2).

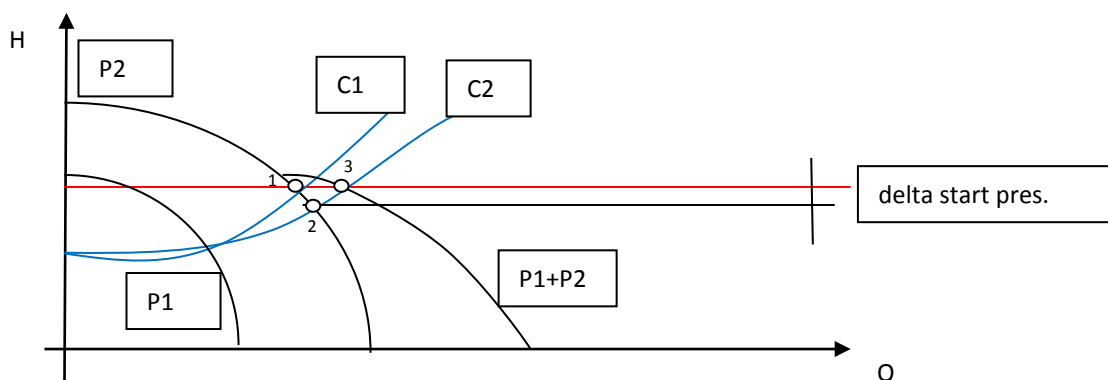

If pump 1 (P1) is already running to maintain the desired set pressure (red line), an additional water request changes the system curve from C1 to C2; since pump 1 (P1) is running at maximum speed, it is not possible to maintain the set pressure by increasing the speed, so the system pressure will drop till reaching the new working point 2.

If pressure at the point 2 is (set value – delta control), VASCO will run the DOL by relay DOL1. The DOL pump will run at its nominal speed while the pump 1 will drop its speed equal to the P1 pattern to maintain set pressure.

If water demands decrease, returning to the system curve C1, pump 1 will reduce the pump speed to maintain constant pressure in the system. When pump 1 reaches a frequency equivalent to the minimum frequency, while still maintaining set pressure, the DOL pump will be switched off and pump 1 will increase the speed to maintain the p_set in the system.

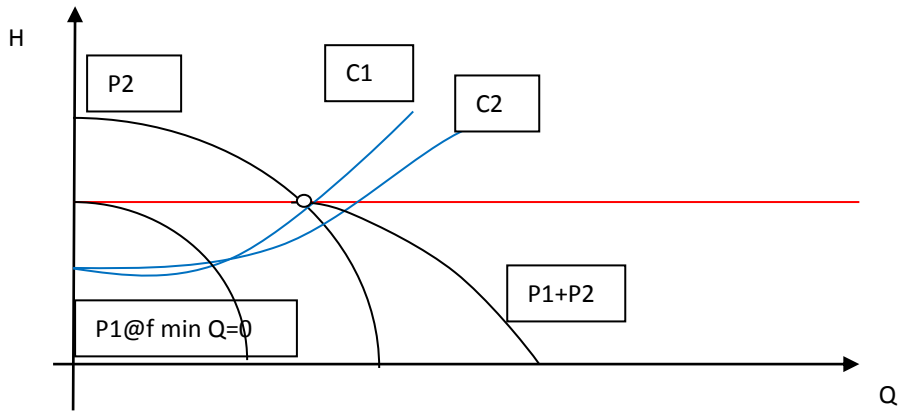

If two pumps are connected in parallel, the first driven by VASCO and the second with a DOL connection, it is necessary to make sure that the value “delta control” will be sufficiently high to ensure the first pump, once the DOL pump is switched on, will reach a frequency higher than its minimum frequency value.
By proper setting of the minimum frequency, excessive pump ON/OFF cycling is avoided, thus preventing damage to the DOL pump.

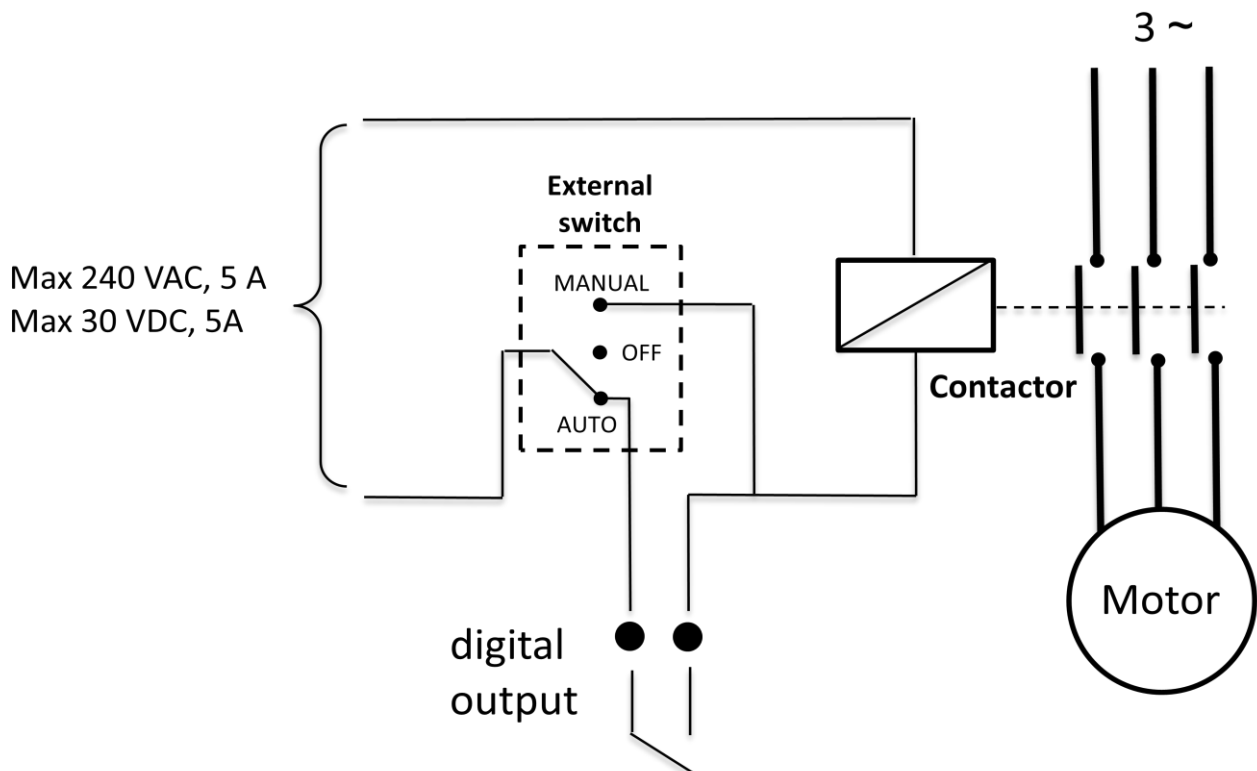

8.2 COMBO function

In the “Installer parameters” menu it is possible to enable the COMBO function that allows serial communication between up to 8 VASCOs, each one connected to a pump. The operating principle (switch on/off) of pumps is similar to as stated in chapter 8.1.

To achieve the COMBO function in a system consisting of several interconnected VASCOs, use a pressure sensor connected to each VASCO. The value of the *set pressure* is communicated to the slaves via the serial port.

To prevent the shutdown of the system due to pressure sensor failure, connecting a 2nd pressure sensor to the VASCO; make sure that the two pressure sensors are identical.

Remember to perform the offset operation of the sensors in each VASCO (Installer Parameters menu).

As a further help, you can connect another two DOL pumps to the VASCO Master to cover additional water demand; they will be operated only when all the COMBO pumps are already in operation.

RS485 serial connection

VASCO's communication is made through a private protocol using the RS485 port. Each VASCO must be connected to each other by using a tripolar cable (0,5 mm²) wired on S+,S-,G pins on control board.

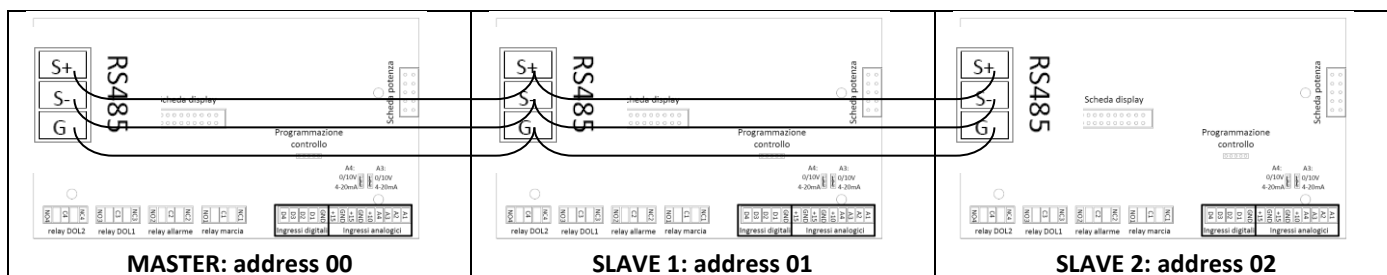

Master setup

1. Supply power to the VASCO master.
2. If not yet completed, perform the initial configuration as described on chapter 6.2
3. Initial view is shown:

Inv: ON/OFF Mot: ON/OFF
p_mis=XX.X [bar]

4. Scroll until:

Menù
ENT to access

5. Press ENT

MENU'
Param. install.

6. Press ENT
7. Insert password (default 001).

8. Scroll until:

Combo
ON/OFF

9. Set ON
10. Set:

Address XX	00	VASCO's address in parallel operation. • 00 : VASCO master
Alternance ON/OFF	OFF	Function to allow alternating between the VASCOs connected in parallel in order to allow equal use of each pump in the group; in this way Master will reorganize the starting priority of the pumps by checking the life of each of them.
Start delay AUX t = XX [s]	0	Delay time with which the slaves start after the variable speed pump has reached the maximum frequency and the pressure value has fallen below set value – delta control

11. Press STOP (red button)
12. Press STOP again

Slave setup

Follow Master setup until point 11.

In case of failure of master in a Combo system, will be replaced by slave. As a consequence, all parameters must be setup independently on each inverter, master mode.

1. Set:

Address XX	VASCO's address in parallel operation. • 01 --> 07: VASCO slaves
---------------	---

2. Press STOP (red button).
3. In the *advanced parameters* verify that *Autorestart* is set *ON*.
4. Press STOP (red button).
5. Press STOP again.

Whenever the user accesses the Menu screen of the VASCO master, the communication between VASCOs is automatically interrupted.

In case of alarm or failure of a pump in a Combo system, this pump's operation will be replaced (temporary or permanently) by another pump.

In case of failure of master in a Combo system, it will be replaced by the next slave after about 1 minute. In order to enable master replacement Autorestart must be set ON in each slaves.

9. Trouble-shooting chart

<p>LCD does not switch on after powering the VASCO</p>	<ul style="list-style-type: none"> • Check the connecting flat cable between the LCD board (attached to the cover) and the control board • Check the fuses • Check that the power cables are properly connected.
<p>Power line of VASCO is interrupted by the differential protection contactor</p>	<ul style="list-style-type: none"> • Check the leakage current to ground of EMC filter • Following a rapid off/on the power supply, the differential contactor can interrupt the power. After turning off the VASCO it is recommended to wait at least 1 minute before restarting.
<p>When performing sensor test operation, SENSOR OFF alarm occurs</p>	<ul style="list-style-type: none"> • Check that the sensor cable is properly connected to the sensor device and to the VASCO. • Make sure that the sensor and its cable are not damaged. • Check that the operating range of sensor is of 4 -20 mA type and the value of 15 V is within the voltage feed range of the sensor.
<p>Frequency and pressure oscillation on constant pressure control mode</p>	<ul style="list-style-type: none"> • Check if the water tank and its air pressure are correctly set. It may be necessary to increase the tank volume or reduce the pre-charge pressure. • Check the ki & kp parameters (Installer Parameters menu). At first, it is suggestable to increase the Ki value. If it not enough reduce of one unit the Kp value.
<p>DOL pump stops and starts continuously</p>	<ul style="list-style-type: none"> • Increase <i>delta control</i>. • Check to see if the water tank and it's air pressure are correctly set. It may be necessary to increase the tank volume or reduce the pre-charge pressure.
<p>Measured pressure drops too much before VASCO starts the pump.</p>	<ul style="list-style-type: none"> • Decrease the delta start value (Installer Parameters menu) . • Check to see if the water tank and it's air pressure are correctly set. It may be necessary to increase the tank volume or reduce the pre-charge pressure. • Modify the value of ki & kp parameters (Installer Parameters menu). At first, it is suggestable to reduce the Ki value. If it is not enough increase of one unit the Kp value.

10. Technical Assistance

For more technical information contact the authorized reseller providing the following information. The solution to the problem will be found faster and easier if full information is provided.

Model/Serial Code	LCD version (shown when VASCO is power supplied) LCD = _._	INV version (shown when VASCO is power supplied) INV = _._
Line Voltage: ___ [V]	Line Frequency: <input type="checkbox"/> 50 Hz <input type="checkbox"/> 60 Hz	
description of problem:		
installation type: <input type="checkbox"/> wall mounted <input type="checkbox"/> on motor fan cover		
motor type: <input type="checkbox"/> single phase <input type="checkbox"/> three phase <input type="checkbox"/> submersible <input type="checkbox"/> surface		
if submersible: cable length [m]: _____		if submersible: cable section [mm ²]: _____
P2 motor [kW]: _____	rated motor Volt [V]: _____	rated motor Amp [A]: _____
rated motor Hz: _____		
if single phase: capacitor _____ [UF]	if single phase: starting Amp I _{st} = _____ [A]	pump performances Q = _____ [l/min] H = _____ [m]
tank volume: _____ [liters]	precharge pressure: _____ [bar]	
number of DOL pumps: _____	number of COMBO pumps: _____	
medium ambient temperature: _____ [°C]	pressure sensor 4 mA = _____ [bar] 20 mA = _____ [bar]	
digital inputs used:	digital outputs used:	
electric and hydraulic scheme of the system (more detailed as possible)		
set parameters: please fill the instal. param. and adv. param columns in the software scheme.		

DECLARATION OF CONFORMITY

In according with:

Machine Directive 2006/42/EC

EMC Directive 2004/108/CE

Low Voltage Directive 2006/95/CE

R&TTE Directive 1999/05/EU

VASCO is an electronic device to be connected to other electrical equipment with which it is to form individual units. It must, therefore, that the putting into service of this unit (with all its subsidiary equipments) to be performed by qualified personnel.

The product conforms to the following regulations:

EN 55011 Class A

EN 61000

EN 60146

EN 50178

EN 60204-1

Ing. Marco Nassuato

Operation Manager



