

WILDEN[®]
Part of Pump Solutions Group
A **DOVER** COMPANY

EOM
Engineering
Operation &
Maintenance

PS1500
Advanced™ Series
Metal Pump

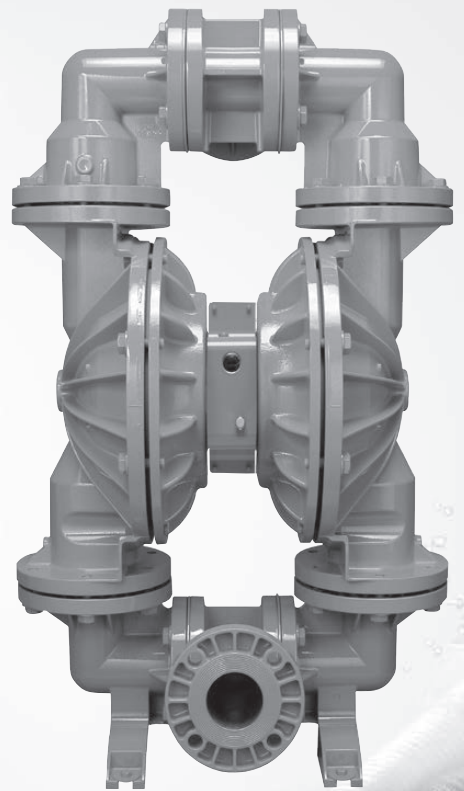

Where Innovation Flows

www.wildenpump.com

PRO-FLO
SHIFT
PROGRESSIVE PUMP TECHNOLOGY



WIL-11420-E-02
TO REPLACE WIL-11420-E-01

TABLE OF CONTENTS

SECTION 1 CAUTIONS—READ FIRST! 1

SECTION 2 WILDEN PUMP DESIGNATION SYSTEM 2

SECTION 3 HOW IT WORKS—PUMP & AIR DISTRIBUTION SYSTEM 3

SECTION 4 DIMENSIONAL DRAWINGS 4

SECTION 5 PERFORMANCE

 PS1500 Aluminum Rubber-Fitted 7

 PS1500 Aluminum EZ-Install TPE-Fitted 7

 PS1500 Aluminum Full-Stroke PTFE-Fitted 8

 PS1500 Stainless Steel Rubber-Fitted 8

 PS1500 Stainless Steel EZ-Install TPE-Fitted 9

 PS1500 Stainless Steel Full-Stroke PTFE-Fitted 9

 PS1500 Drop-In Stainless Steel Rubber-Fitted 10

 PS1500 Drop-In Stainless Steel EZ-Install TPE-Fitted 10

 PS1500 Drop-In Stainless Steel Full-Stroke PTFE-Fitted 11

 Suction Lift Curves 12

SECTION 6 SUGGESTED INSTALLATION, OPERATION & TROUBLESHOOTING 14

SECTION 7 ASSEMBLY / DISASSEMBLY 17

 Air Valve / Center Section Disassembly 20

 Reassembly Hints & Tips 24

SECTION 8 EXPLODED VIEW & PARTS LISTING

 PS1500 Aluminum 26

 PS1500 Stainless Steel 28

 PS1500 Aluminum Drop-In 30

 PS1500 Stainless Steel Drop-In 32

SECTION 9 ELASTOMER OPTIONS 34

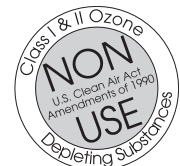

CAUTIONS—READ FIRST!



CAUTION: Do not apply compressed air to the exhaust port — pump will not function.



CAUTION: Do not over-lubricate air supply — excess lubrication will reduce pump performance. Pump is pre-lubed.



TEMPERATURE LIMITS:

Polypropylene	0°C to 79°C	32°F to 175°F
PVDF	-12°C to 107°C	10°F to 225°F
PFA	7°C to 107°C	20°F to 225°F
Neoprene	-18°C to 93°C	0°F to 200°F
Buna-N	-12°C to 82°C	10°F to 180°F
EPDM	-51°C to 138°C	-60°F to 280°F
Viton® FKM	-40°C to 177°C	-40°F to 350°F
Wil-Flex™	-40°C to 107°C	-40°F to 225°F
Saniflex™	-29°C to 104°C	-20°F to 220°F
Polyurethane	-12°C to 66°C	10°F to 150°F
Polytetrafluoroethylene (PTFE) ¹	4°C to 104°C	40°F to 220°F
Nylon	-18°C to 93°C	0°F to 200°F
Acetal	-29°C to 82°C	-20°F to 180°F
SIPD PTFE with Neoprene-backed	4°C to 104°C	40°F to 220°F
SIPD PTFE with EPDM-backed	-10°C to 137°C	14°F to 280°F
Polyethylene	0°C to 70°C	32°F to 158°F
Geolast®	-40°C to 82°C	-40°F to 180°F

¹4°C to 149°C (40°F to 300°F) - 13 mm (1/2") and 25 mm (1") models only.



CAUTION: When choosing pump materials, be sure to check the temperature limits for all wetted components. Example: Viton® has a maximum limit of 177°C (350°F) but polypropylene has a maximum limit of only 79°C (175°F).



CAUTION: Maximum temperature limits are based upon mechanical stress only. Certain chemicals will significantly reduce maximum safe operating temperatures. Consult Chemical Resistance Guide (E4) for chemical compatibility and temperature limits.



WARNING: Prevent static sparking. If static sparking occurs, fire or explosion could result. Pump, valves and containers must be grounded to a proper grounding point when handling flammable fluids and whenever discharge of static electricity is a hazard.



CAUTION: Do not exceed 8.6 bar (125 psig) air supply pressure.



CAUTION: The process fluid and cleaning fluids must be chemically compatible with all wetted pump components (see E4).



CAUTION: Do not exceed 82°C (180°F) air inlet temperature for Pro-Flo® SHIFT models.



CAUTION: Pumps should be thoroughly flushed before installing into process lines. FDA- and USDA-approved pumps should be cleaned and/or sanitized before being used.



CAUTION: Always wear safety glasses when operating pump. If diaphragm rupture occurs, material being pumped may be forced out air exhaust.



CAUTION: Before any maintenance or repair is attempted, the compressed air line to the pump should be disconnected and all air pressure allowed to bleed from pump. Disconnect all intake, discharge and air lines. Drain the pump by turning it upside down and allowing any fluid to flow into a suitable container.



CAUTION: Blow out air line for 10 to 20 seconds before attaching to pump to make sure all pipeline debris is clear. Use an in-line air filter. A 5µ (micron) air filter is recommended.



NOTE: When installing PTFE diaphragms, it is important to tighten outer pistons simultaneously (turning in opposite directions) to ensure tight fit. (See torque specifications in Section 7.)



NOTE: Cast Iron PTFE-fitted pumps come standard from the factory with expanded PTFE gaskets installed in the diaphragm bead of the liquid chamber. PTFE gaskets cannot be re-used. Consult PS-TG for installation instructions during reassembly.



NOTE: Before starting disassembly, mark a line from each liquid chamber to its corresponding air chamber. This line will assist in proper alignment during reassembly.



CAUTION: Pro-Flo® pumps cannot be used in submersible applications. Pro-Flo® SHIFT pumps do have a single-point exhaust option for submersible applications. Do not use standard Pro-Flo® SHIFT models in submersible applications. Pro-Flo X™ and Turbo-Flo® pumps are also available in a single-point exhaust (submersible) configuration.



CAUTION: Tighten all hardware prior to installation.



WILDEN PUMP DESIGNATION SYSTEM

PS1500 METAL

**76 mm (3") Pump
Maximum Flow Rate:
1056 lpm (279 gpm)**

LEGEND

XPS1500 / XXXXX / XXX / XX / XXX / XXXX

MODEL

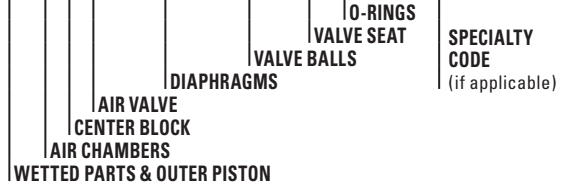

MATERIAL CODES

MODEL

XPS1500 = PRO-FLO® SHIFT ATEX

WETTED PARTS/OUTER PISTON

AA = ALUMINUM / ALUMINUM
HH = ALLOY C / ALLOY C
SS = STAINLESS STEEL / STAINLESS STEEL

AIR CHAMBERS

A = ALUMINUM
S = STAINLESS STEEL

CENTER BLOCK

A = ALUMINUM
N = NICKEL-PLATED

AIR VALVE

A = ALUMINUM
N = NICKEL-PLATED
R = ANODIZED ALUMINUM

DIAPHRAGMS

BNS = BUNA-N (Red Dot)
EPS = EPDM (Blue Dot)
FWS = SANITARY WIL-FLEX™, EZ-INSTALL [Santoprene® (Two Orange Dots)]
NES = NEOPRENE (Green Dot)
TSS = FULL STROKE PTFE W/SANIFLEX™ BACK-UP
TWS = FULL STROKE PTFE W/WIL-FLEX™ BACK-UP
VTS = VITON® (White Dot)
XBS = CONDUCTIVE BUNA-N (Two Red Dots)
ZGS = GEOLAST®, EZ-INSTALL
ZPS = POLYURETHANE, EZ-INSTALL
ZSS = SANIFLEX™, EZ-INSTALL
ZWS = WIL-FLEX™, EZ-INSTALL

VALVE BALLS

BN = BUNA-N (Red Dot)
FS = SANIFLEX™ [Hytre® (Cream)]
FW = SANITARY WIL-FLEX™ [Santoprene® (Two Orange Dots)]
EP = EPDM (Blue Dot)
NE = NEOPRENE (Green Dot)
PU = POLYURETHANE (Brown)
TF = PTFE (White)
VT = VITON® (Silver or White Dot)

VALVE SEAT

BN = BUNA-N (Red Dot)
EP = EPDM (Blue Dot)
FS = SANIFLEX™ [Hytre® (Cream)]
FW = SANITARY WIL-FLEX™ [Santoprene® (Two Orange Dots)]
H = ALLOY C
M = MILD STEEL
NE = NEOPRENE (Green Dot)
PU = POLYURETHANE (Brown)
S = STAINLESS STEEL
VT = VITON® (White Dot)

VALVE SEAT O-RING

TF = PTFE (White)

SPECIALTY CODES

0044 Stallion balls & seats ONLY
0100 Wil-Gard 110V
0102 Wil-Gard sensor wires ONLY
0103 Wil-Gard 220V
0320 Single-Point Exhaust

0480 Pump Cycle Monitor (sensor & wires)
0483 Pump Cycle Monitor (module, sensor & wires)
0485 Pump Cycle Monitor (module, sensor & wires), DIN flange
0504 DIN flange
0540 Advanced Drop-in, ANSI Flange
0544 Advanced Drop-in, DIN Flange

0560 Split manifold
0563 Split manifold, discharge ONLY
0564 Split manifold, inlet ONLY
0677 Center-Ported, NPT Inlet & Discharge
0678 Center-Ported, BSPT Inlet & Discharge
0877 Center-Ported Aluminum, NPT Inlet & Discharge
0878 Center-Ported Aluminum, BSP Inlet & Discharge

NOTE: Most elastomeric materials use colored dots for identification.
NOTE: Not all models are available with all material options.

Viton® is a registered trademark of DuPont Dow Elastomers.



HOW IT WORKS—PUMP

The Wilden diaphragm pump is an air-operated, positive displacement, self-priming pump. These drawings show flow pattern through the pump upon its initial stroke. It is assumed the pump has no fluid in it prior to its initial stroke.

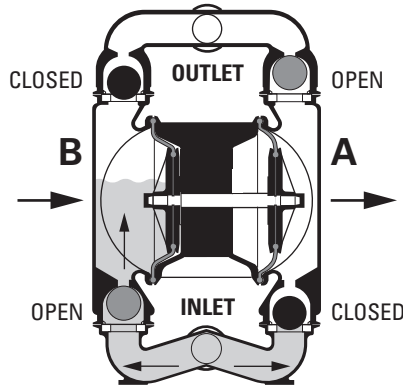

FIGURE 1 The air valve directs pressurized air to the back side of diaphragm A. The compressed air is applied directly to the liquid column separated by elastomeric diaphragms. The diaphragm acts as a separation membrane between the compressed air and liquid, balancing the load and removing mechanical stress from the diaphragm. The compressed air moves the diaphragm away from the center of the pump. The opposite diaphragm is pulled in by the shaft connected to the pressurized diaphragm. Diaphragm B is on its suction stroke; air behind the diaphragm has been forced out to atmosphere through the exhaust port of the pump. The movement of diaphragm B toward the center of the pump creates a vacuum within chamber B. Atmospheric pressure forces fluid into the inlet manifold forcing the inlet valve ball off its seat. Liquid is free to move past the inlet valve ball and fill the liquid chamber (see shaded area).

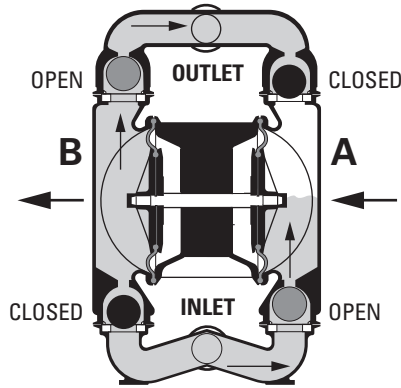

FIGURE 2 When the pressurized diaphragm, diaphragm A, reaches the limit of its discharge stroke, the air valve redirects pressurized air to the back side of diaphragm B. The pressurized air forces diaphragm B away from the center while pulling diaphragm A to the center. Diaphragm B is now on its discharge stroke. Diaphragm B forces the inlet valve ball onto its seat due to the hydraulic forces developed in the liquid chamber and manifold of the pump. These same hydraulic forces lift the discharge valve ball off its seat, while the opposite discharge valve ball is forced onto its seat, forcing fluid to flow through the pump discharge. The movement of diaphragm A toward the center of the pump creates a vacuum within liquid chamber A. Atmospheric pressure forces fluid into the inlet manifold of the pump. The inlet valve ball is forced off its seat allowing the fluid being pumped to fill the liquid chamber.

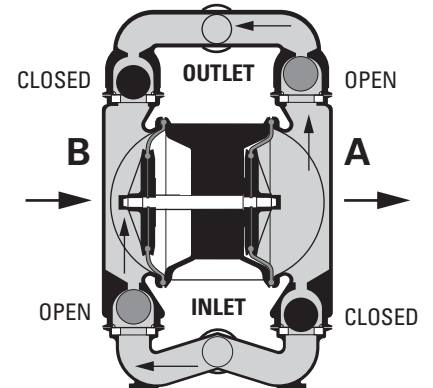
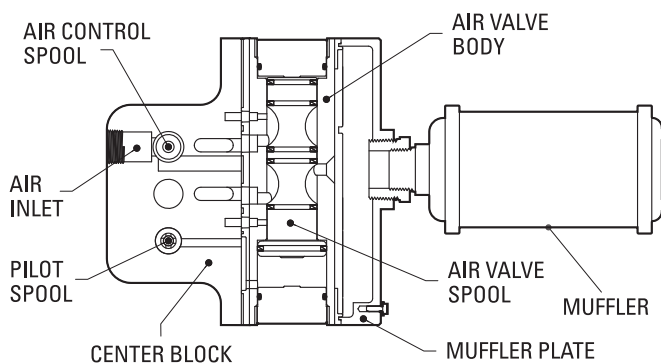

FIGURE 3 At completion of the stroke, the air valve again redirects air to the back side of diaphragm A, which starts diaphragm B on its exhaust stroke. As the pump reaches its original starting point, each diaphragm has gone through one exhaust and one discharge stroke. This constitutes one complete pumping cycle. The pump may take several cycles to completely prime depending on the conditions of the application.



HOW IT WORKS—AIR DISTRIBUTION SYSTEM



The heart of the patented Pro-Flo® SHIFT Air Distribution System (ADS) is the air valve assembly. The air valve design incorporates an unbalanced spool with the small end of the spool being pressurized continuously while the large end of the spool is alternately pressurized, then exhausted to move the spool. The air valve spool directs pressurized air to one chamber while exhausting the other. The air forces the main shaft/diaphragm assembly to move to one side – discharging liquid on that side and pulling liquid in on the other side. When the shaft reaches the end of the stroke, the inner piston actuates the pilot spool, which controls the air to the large end of the air valve spool. The repositioning of the air valve spool routes the air to the other air chamber. The air control spool allows air to flow freely into the air chamber for the majority of each pump stroke, but it significantly restricts the flow of air into the air chamber when activated by the inner piston near the end of the each stroke.



DIMENSIONAL DRAWINGS

PS1500 Metal – Aluminum

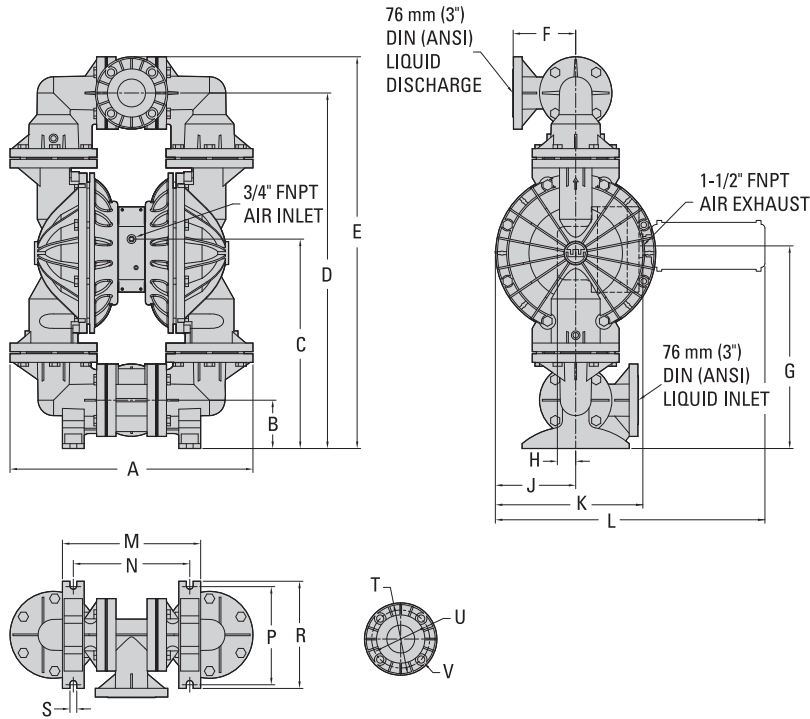

DIMENSIONS

ITEM	METRIC (mm)	STANDARD (inch)
A	615	24.2
B	127	5.0
C	551	21.7
D	934	36.8
E	1031	40.6
F	165	6.5
G	533	21.0
H	48	1.9
J	211	8.3
K	388	15.3
L	709	27.9
M	363	14.3
N	307	12.1
P	259	10.2
R	282	11.1
S	18	0.7
	DIN (mm)	ANSI (inch)
T	200 DIA.	7.5 DIA.
U	160 DIA.	6.0 DIA.
V	18 DIA.	0.8 DIA.

LW0033 REV. A

PS1500 Metal Drop-in – Aluminum

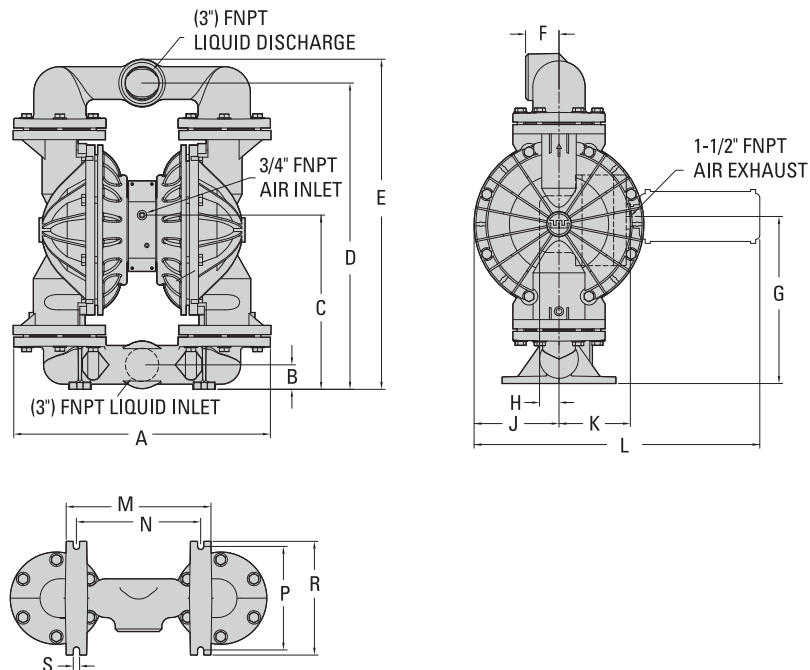

DIMENSIONS

ITEM	METRIC (mm)	STANDARD (inch)
A	635	25
B	61	2.4
C	432	17.0
D	759	29.9
E	818	32.2
F	84	3.3
G	414	16.3
H	48	1.9
J	211	8.3
K	177	7.0
L	708	27.9
M	358	14.1
N	307	12.1
P	257	10.1
R	282	11.1
S	15	0.6

LW0034 REV. A

PS1500 Metal – Stainless Steel

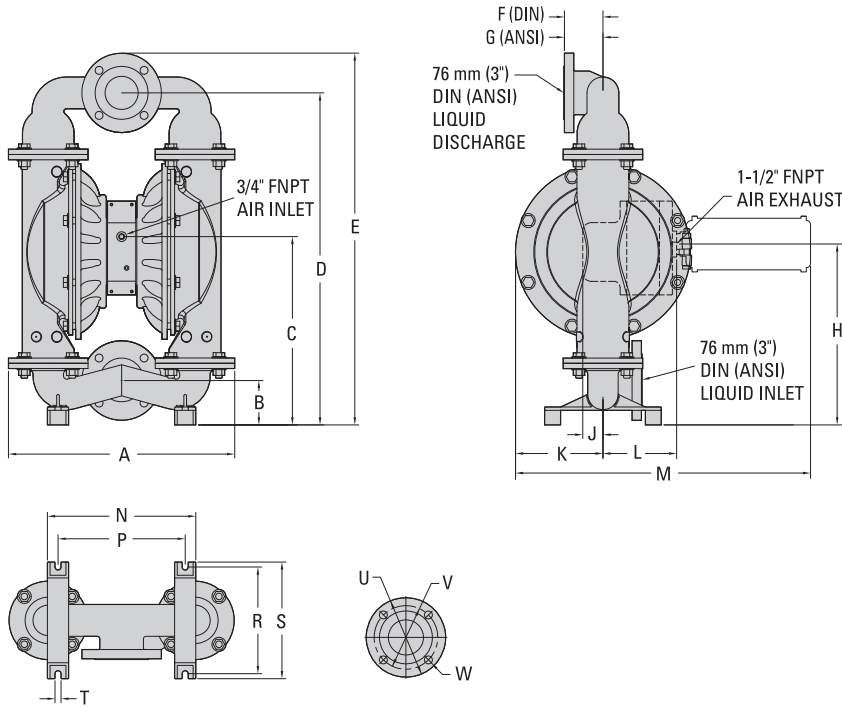

DIMENSIONS

ITEM	METRIC (mm)	STANDARD (inch)
A	541	21.3
B	107	4.2
C	451	17.8
D	795	31.3
E	892	35.1
F	89	3.5
G	91	3.6
H	433	17.1
J	48	1.9
K	211	8.3
L	177	7.0
M	707	27.8
N	356	14.0
P	305	12.0
R	257	10.1
S	279	11.0
T	15	0.6
	DIN (mm)	ANSI (inch)
U	200 DIA.	7.5 DIA.
V	160 DIA.	6.0 DIA.
W	18 DIA.	0.8 DIA.

LW0035 REV. A

PS1500 Metal Drop-In – Stainless Steel

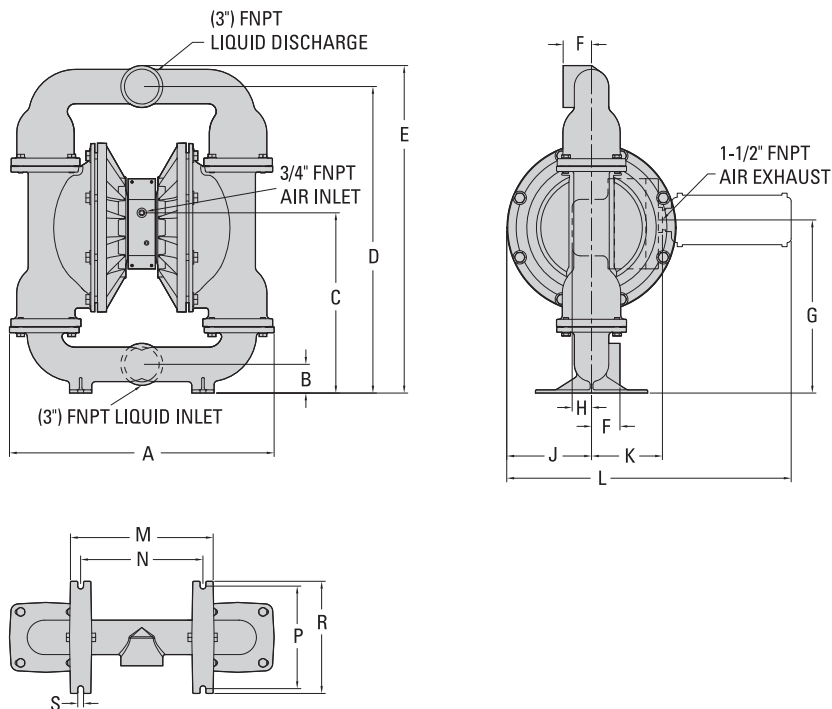

DIMENSIONS

ITEM	METRIC (mm)	STANDARD (inch)
A	650	25.6
B	71	2.8
C	449	17.7
D	765	30.1
E	815	32.1
F	71	2.8
G	431	17.0
H	48	1.9
J	211	8.3
K	177	7.0
L	709	27.9
M	356	14.0
N	305	12.0
P	257	10.1
R	279	11.0
S	15	0.6

LW0036 REV. A

PS1500 Metal Drop-In – Flanged Stainless Steel

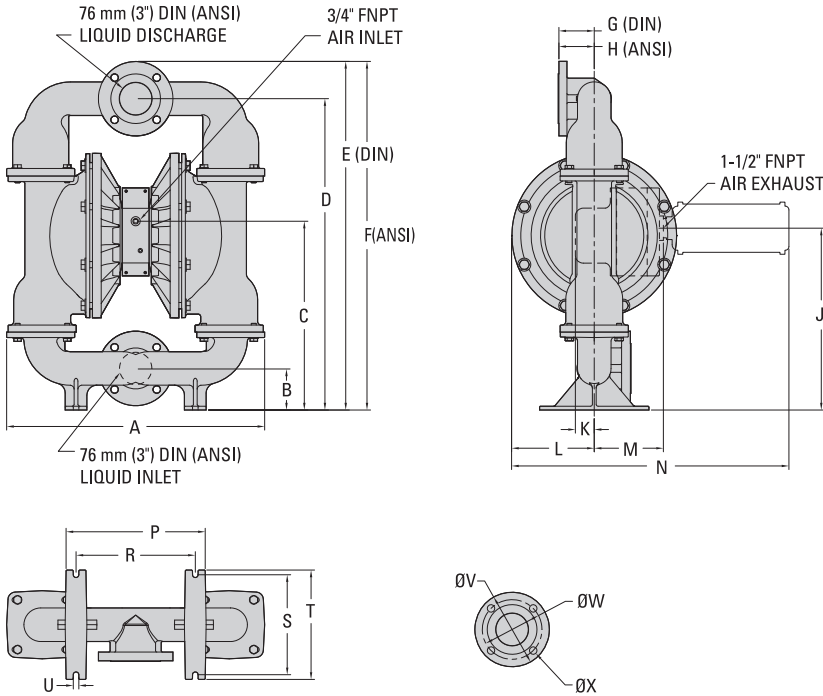

DIMENSIONS

ITEM	METRIC (mm)	STANDARD (inch)
A	659	26.0
B	105	4.1
C	483	19.0
D	796	31.3
E	896	35.3
F	890	35.1
G	88	3.5
H	90	3.6
J	465	18.3
K	48	1.9
L	211	8.3
M	177	7.0
N	709	27.9
P	356	14.0
R	305	12.0
S	256	10.1
T	279	11.0
U	14	0.6
	DIN (mm)	ANSI (inch)
V	Ø 200	Ø 7.5
W	Ø 160	Ø 6.0
X	Ø 18	Ø 0.8

LW0037 REV. A



PERFORMANCE

PS1500 ALUMINUM RUBBER-FITTED

Height 1031 mm (40.6")
 Width 615 mm (24.2")
 Depth 389 mm (15.3")
 Ship Weight Aluminum 83 kg (182 lbs)
 Aluminum Drop-In 69 kg (152 lbs)
 Air Inlet 19 mm (3/4")
 Inlet 76 mm (3")
 Outlet 76 mm (3")
 Suction Lift 7.2 m Dry (23.8')
 9.0 m Wet (29.5')
 Disp. per Stroke 5.1 L (1.35 gal)¹
 Max. Flow Rate 1045 lpm (276 gpm)
 Max. Size Solids 12.7 mm (1/2")

¹Displacement per stroke was calculated at 4.8 bar (70 psig) air inlet pressure against a 2.1 bar (30 psig) head pressure.

Example: To pump 712 lpm (188 gpm) against a discharge head of 1.4 bar (20 psig) requires 5.5 bar (80 psig) and 163 Nm³/h (96 scfm) air consumption.

Caution: Do not exceed 8.6 bar (125 psig) air supply pressure.

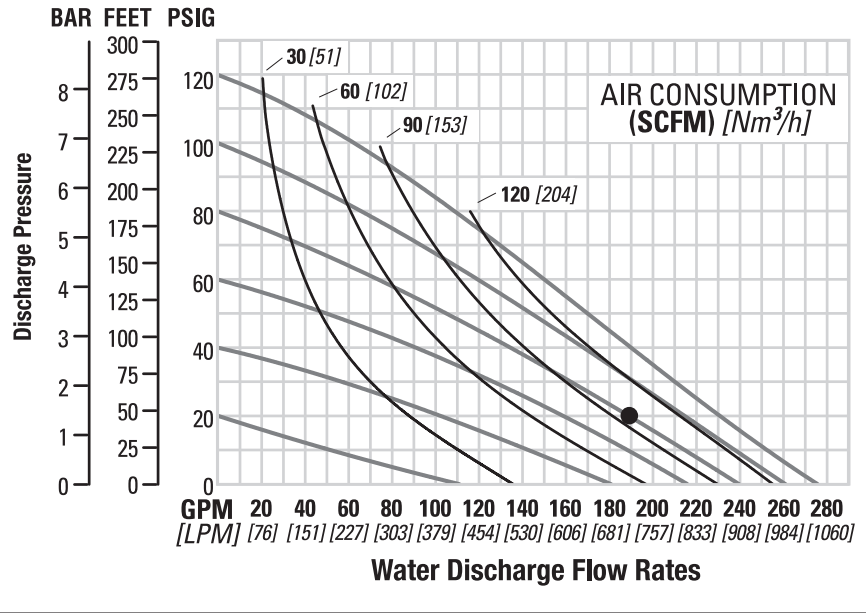

Flow rates indicated on chart were determined by pumping water.
 For optimum life and performance, pumps should be specified so that daily operation parameters will fall in the center of the pump's performance curve.

PS1500 ALUMINUM EZ-INSTALL TPE-FITTED

Height 1031 mm (40.6")
 Width 615 mm (24.2")
 Depth 389 mm (15.3")
 Ship Weight Aluminum 83 kg (182 lbs)
 Aluminum Drop-In 69 kg (152 lbs)
 Air Inlet 19 mm (3/4")
 Inlet 76 mm (3")
 Outlet 76 mm (3")
 Suction Lift 6.4 m Dry (21.1')
 9.0 m Wet (29.5')
 Disp. per Stroke 5.1 L (1.35 gal)¹
 Max. Flow Rate 1026 lpm (271 gpm)
 Max. Size Solids 12.7 mm (1/2")

¹Displacement per stroke was calculated at 4.8 bar (70 psig) air inlet pressure against a 2.1 bar (30 psig) head pressure.

Example: To pump 337 lpm (89 gpm) against a discharge head of 2.8 bar (40 psig) requires 4.1 bar (60 psig) and 85 Nm³/h (50 scfm) air consumption.

Caution: Do not exceed 8.6 bar (125 psig) air supply pressure.

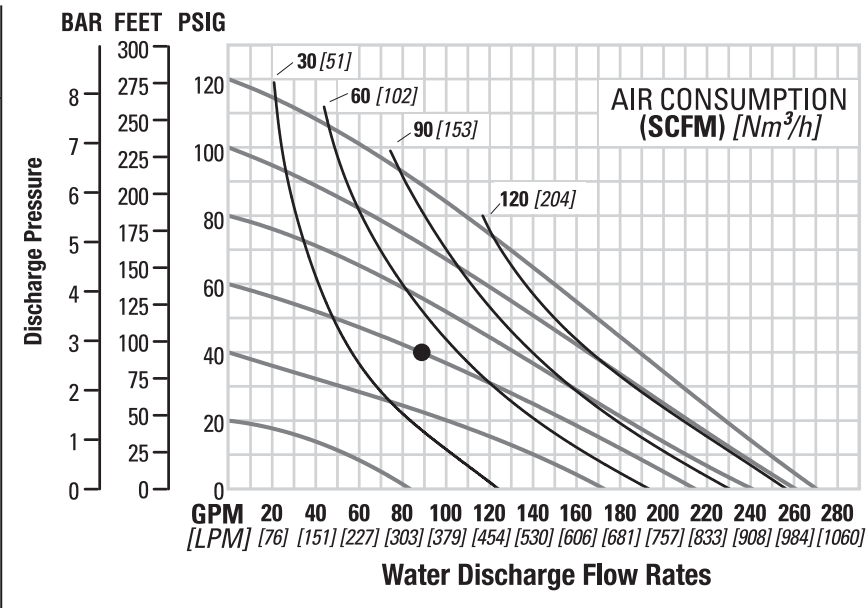

Flow rates indicated on chart were determined by pumping water.
 For optimum life and performance, pumps should be specified so that daily operation parameters will fall in the center of the pump's performance curve.

PS1500 ALUMINUM FULL-STROKE PTFE-FITTED

Height 1031 mm (40.6")
 Width 615 mm (24.2")
 Depth 389 mm (15.3")
 Ship Weight Aluminum 83 kg (182 lbs)
 Aluminum Drop-In 69 kg (152 lbs)
 Air Inlet 19 mm (3/4")
 Inlet 76 mm (3")
 Outlet 76 mm (3")
 Suction Lift 6.2 m Dry (20.2')
 8.6 m Wet (28.4')
 Disp. per Stroke 4.9 L (1.30 gal)¹
 Max. Flow Rate 977 lpm (258 gpm)
 Max. Size Solids 12.7 mm (1/2")

¹Displacement per stroke was calculated at 4.8 bar (70 psig) air inlet pressure against a 2.1 bar (30 psig) head pressure.

Example: To pump 572 lpm (151 gpm) against a discharge head of 1.4 bar (20 psig) requires 4.1 bar (60 psig) and 114 Nm³/h (67 scfm) air consumption.

Caution: Do not exceed 8.6 bar (125 psig) air supply pressure.

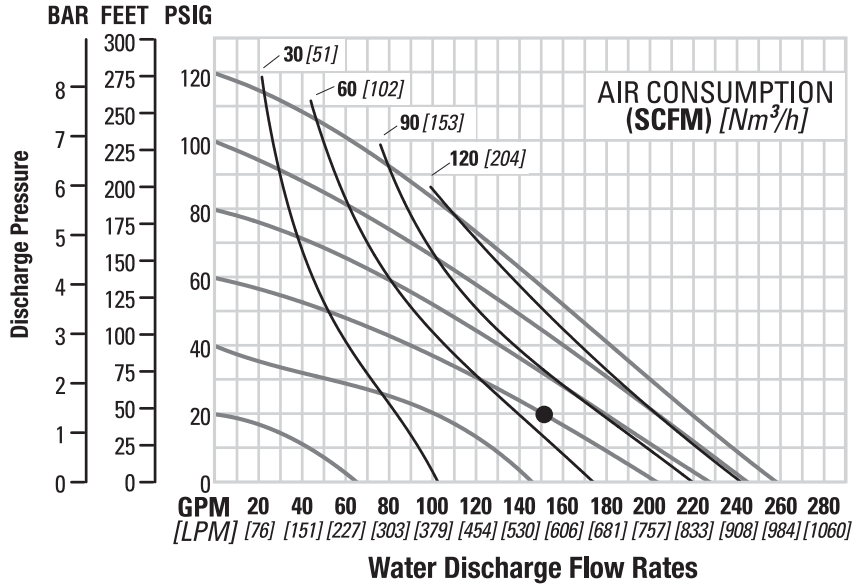

Flow rates indicated on chart were determined by pumping water.

For optimum life and performance, pumps should be specified so that daily operation parameters will fall in the center of the pump's performance curve.

PS1500 STAINLESS STEEL RUBBER-FITTED

Height 892 mm (35.1")
 Width 541 mm (21.3")
 Depth 389 mm (15.3")
 Ship Weight Stainless Steel 125 kg (275 lbs)
 Alloy C 130 kg (287 lbs)
 Air Inlet 19 mm (3/4")
 Inlet 76 mm (3")
 Outlet 76 mm (3")
 Suction Lift 6.4 m Dry (21.0')
 8.6 m Wet (28.4')
 Disp. per Stroke 5.3 L (1.39 gal)¹
 Max. Flow Rate 939 lpm (248 gpm)
 Max. Size Solids 9.5 mm (3/8")

¹Displacement per stroke was calculated at 4.8 bar (70 psig) air inlet pressure against a 2.1 bar (30 psig) head pressure.

Example: To pump 549 lpm (145 gpm) against a discharge head of 1.4 bar (20 psig) requires 4.1 bar (60 psig) and 116 Nm³/h (68 scfm) air consumption.

Caution: Do not exceed 8.6 bar (125 psig) air supply pressure.

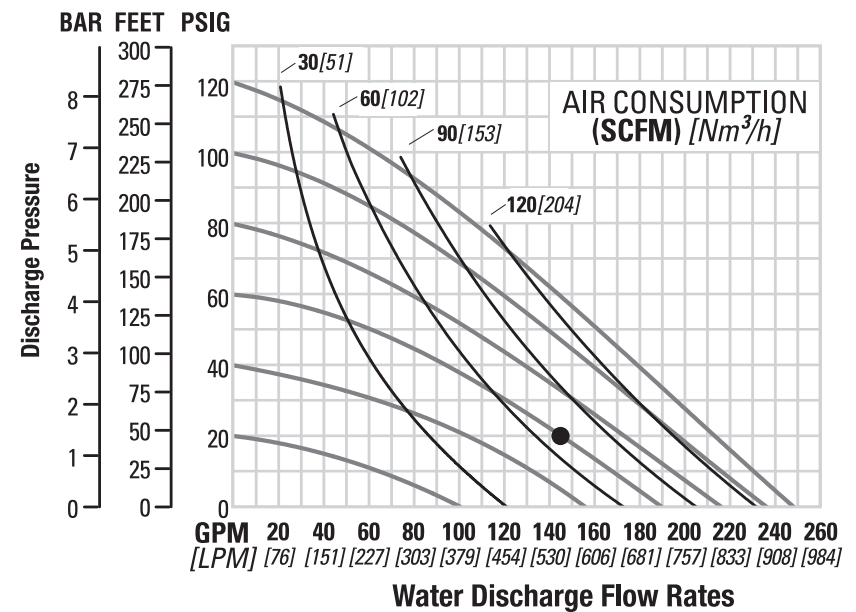

Flow rates indicated on chart were determined by pumping water.

For optimum life and performance, pumps should be specified so that daily operation parameters will fall in the center of the pump's performance curve.

**PS1500 STAINLESS STEEL
EZ-INSTALL TPE-FITTED**

Height 892 mm (35.1")
 Width 541 mm (21.3")
 Depth 389 mm (15.3")
 Ship Weight Stainless Steel 125 kg (275 lbs)
 Alloy C 130 kg (287 lbs)
 Air Inlet 19 mm (3/4")
 Inlet 76 mm (3")
 Outlet 76 mm (3")
 Suction Lift 6.2 m Dry (20.4')
 8.6 m Wet (28.4')
 Disp. per Stroke 5.3 L (1.41 gal)¹
 Max. Flow Rate 927 lpm (245 gpm)
 Max. Size Solids 9.5 mm (3/8")

¹Displacement per stroke was calculated at 4.8 bar (70 psig) air inlet pressure against a 2.1 bar (30 psig) head pressure.

Example: To pump 481 lpm (127 gpm) against a discharge head of 2.8 bar (40 psig) requires 5.5 bar (80 psig) and 139 Nm³/h (82 scfm) air consumption.

Caution: Do not exceed 8.6 bar (125 psig) air supply pressure.

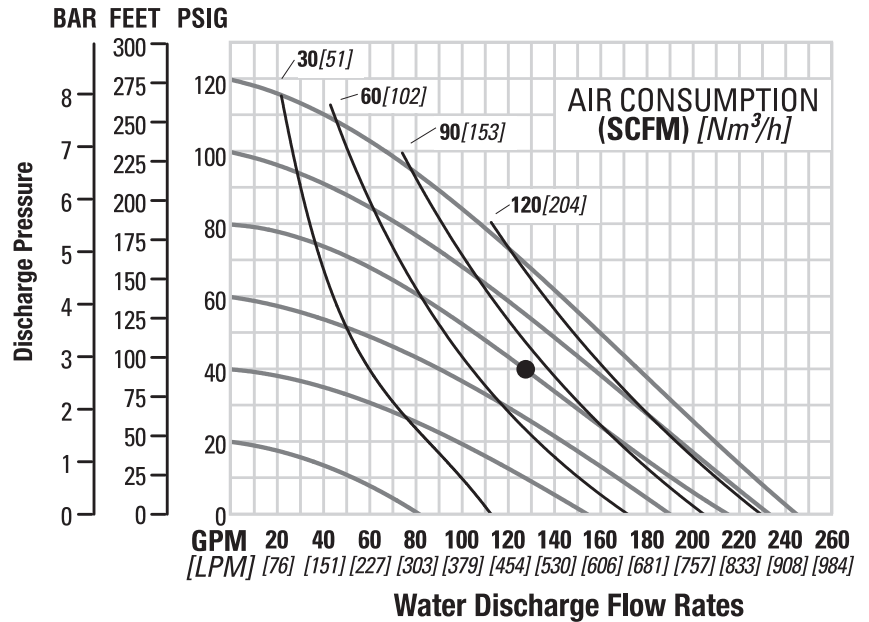

Flow rates indicated on chart were determined by pumping water.

For optimum life and performance, pumps should be specified so that daily operation parameters will fall in the center of the pump's performance curve.

**PS1500 STAINLESS STEEL
FULL-STROKE PTFE-FITTED**

Height 892 mm (35.1")
 Width 541 mm (21.3")
 Depth 389 mm (15.3")
 Ship Weight Stainless Steel 125 kg (275 lbs)
 Alloy C 130 kg (287 lbs)
 Air Inlet 19 mm (3/4")
 Inlet 76 mm (3")
 Outlet 76 mm (3")
 Suction Lift 4.9 m Dry (19.5')
 8.6 m Wet (28.4')
 Disp. per Stroke 4.9 L (1.29 gal)¹
 Max. Flow Rate 931 lpm (246 gpm)
 Max. Size Solids 9.5 mm (3/8")

¹Displacement per stroke was calculated at 4.8 bar (70 psig) air inlet pressure against a 2.1 bar (30 psig) head pressure.

Example: To pump 719 lpm (190 gpm) against a discharge head of 1.4 bar (20 psig) requires 6.9 bar (100 psig) and 206 Nm³/h (121 scfm) air consumption.

Caution: Do not exceed 8.6 bar (125 psig) air supply pressure.

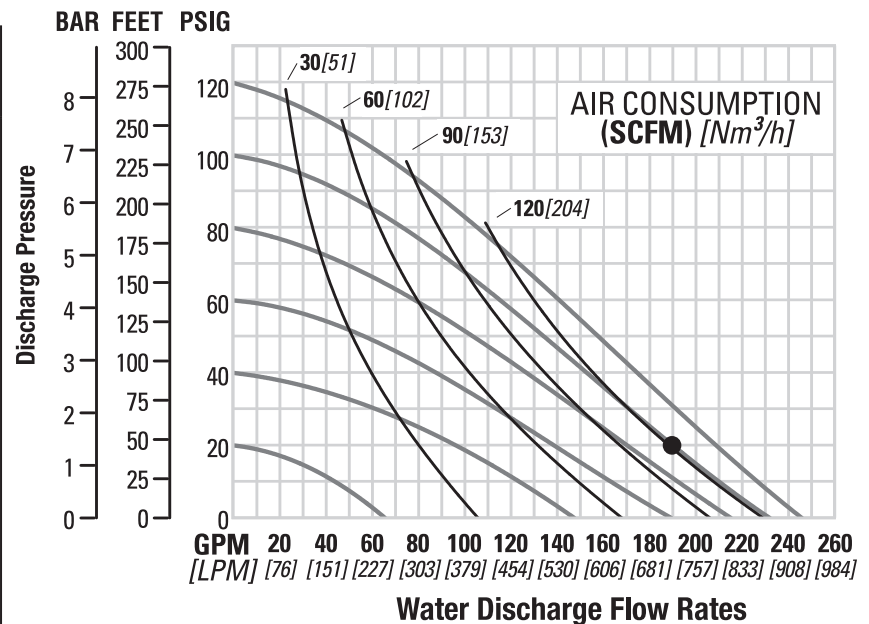

Flow rates indicated on chart were determined by pumping water.

For optimum life and performance, pumps should be specified so that daily operation parameters will fall in the center of the pump's performance curve.

**PS1500 DROP-IN SS
RUBBER-FITTED**

Height 815 mm (32.1")
 Width 650 mm (25.6")
 Depth 389 mm (15.3")
 Ship Weight 126 kg (278 lbs)
 Air Inlet 19 mm (3/4")
 Inlet 76 mm (3")
 Outlet 76 mm (3")
 Suction Lift 6.0 m Dry (19.7')
 8.6 m Wet (28.4')
 Disp. per Stroke 5.0 L (1.32 gal)¹
 Max. Flow Rate 1026 lpm (271 gpm)
 Max. Size Solids..... 12.7 mm (1/2")

¹Displacement per stroke was calculated at 4.8 bar (70 psig) air inlet pressure against a 2.1 bar (30 psig) head pressure.

Example: To pump 700 lpm (185 gpm) against a discharge head of 1.4 bar (20 psig) requires 5.5 bar (80 psig) and 161 Nm³/h (95 scfm) air consumption.

Caution: Do not exceed 8.6 bar (125 psig) air supply pressure.

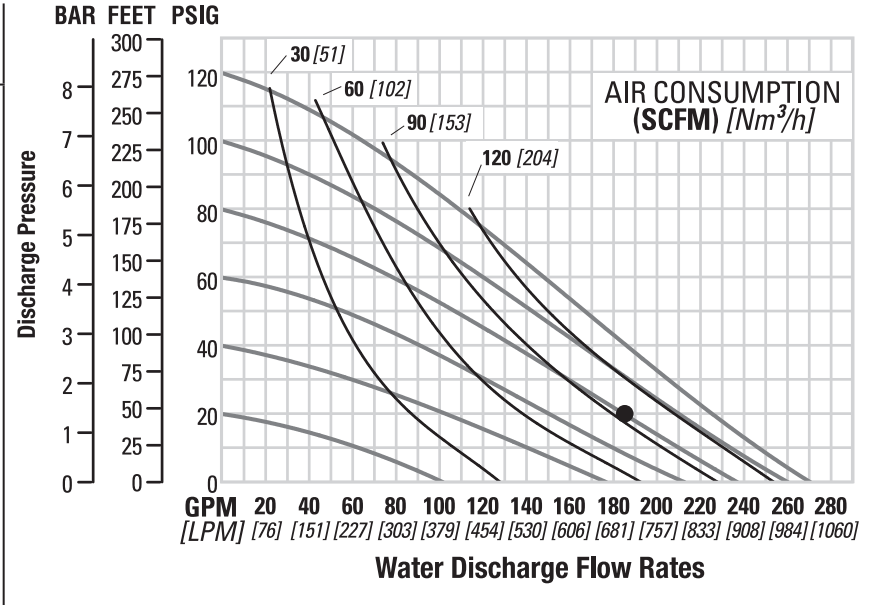

Flow rates indicated on chart were determined by pumping water.

For optimum life and performance, pumps should be specified so that daily operation parameters will fall in the center of the pump's performance curve.

**PS1500 DROP-IN SS
EZ-INSTALL TPE-FITTED**

Height 815 mm (32.1")
 Width 650 mm (25.6")
 Depth 389 mm (15.3")
 Ship Weight 126 kg (278 lbs)
 Air Inlet 19 mm (3/4")
 Inlet 76 mm (3")
 Outlet 76 mm (3")
 Suction Lift 5.4 m Dry (17.6')
 8.6 m Wet (28.4')
 Disp. per Stroke 5.4 L (1.43 gal)¹
 Max. Flow Rate 1056 lpm (279 gpm)
 Max. Size Solids..... 12.7 mm (1/2")

¹Displacement per stroke was calculated at 4.8 bar (70 psig) air inlet pressure against a 2.1 bar (30 psig) head pressure.

Example: To pump 594 lpm (157 gpm) against a discharge head of 1.4 bar (20 psig) requires 4.1 bar (60 psig) and 119 Nm³/h (70 scfm) air consumption.

Caution: Do not exceed 8.6 bar (125 psig) air supply pressure.

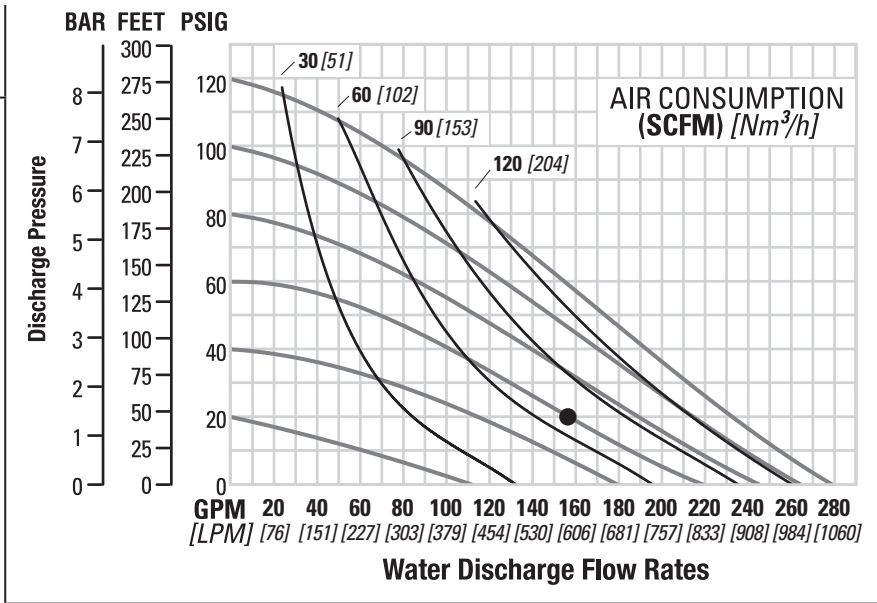

Flow rates indicated on chart were determined by pumping water.

For optimum life and performance, pumps should be specified so that daily operation parameters will fall in the center of the pump's performance curve.

PERFORMANCE

PS1500 DROP-IN SS FULL-STROKE PTFE-FITTED

Height	815 mm (32.1")
Width	650 mm (25.6")
Depth	389 mm (15.3")
Ship Weight	126 kg (278 lbs)
Air Inlet	19 mm (3/4")
Inlet	76 mm (3")
Outlet	76 mm (3")
Suction Lift	5.9 m Dry (19.3')
	8.6 m Wet (28.4')
Disp. per Stroke	5.0 L (1.32 gal) ¹
Max. Flow Rate	992 lpm (262 gpm)
Max. Size Solids.....	12.7 mm (1/2")

¹Displacement per stroke was calculated at 4.8 bar (70 psig) air inlet pressure against a 2.1 bar (30 psig) head pressure.

Example: To pump 420 lpm (111 gpm) against a discharge head of 2.8 bar (40 psig) requires 4.8 bar (70 psig) and 110 Nm³/h (65 scfm) air consumption.

Caution: Do not exceed 8.6 bar (125 psig) air supply pressure.

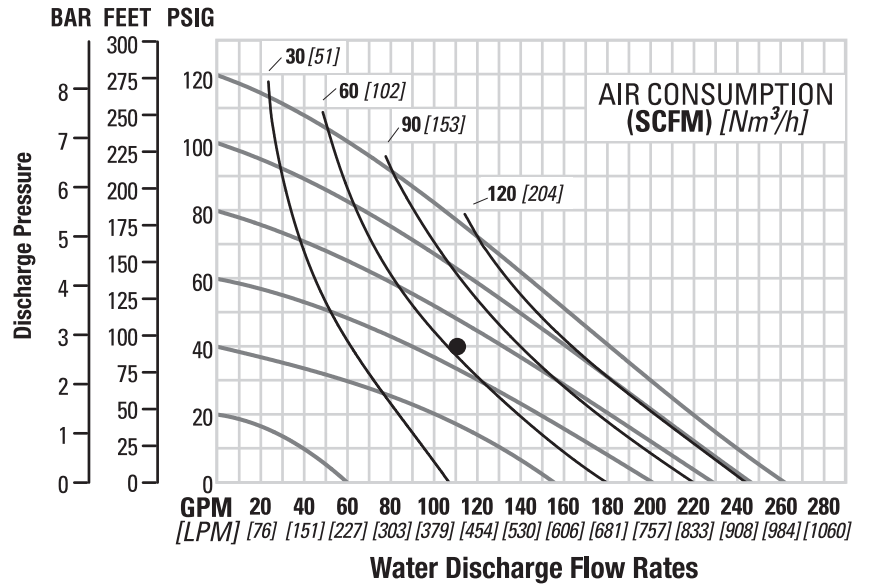

Flow rates indicated on chart were determined by pumping water.

For optimum life and performance, pumps should be specified so that daily operation parameters will fall in the center of the pump's performance curve.

SUCTION-LIFT CURVES

PS1500 ALUMINUM SUCTION-LIFT CAPABILITY

Suction-lift curves are calibrated for pumps operating at 305 m (1,000') above sea level. This chart is meant to be a guide only. There are many variables that can affect your pump's operating characteristics. The number of intake and discharge elbows, viscosity of pumping fluid, elevation (atmospheric pressure) and pipe friction loss all affect the amount of suction lift your pump will attain.

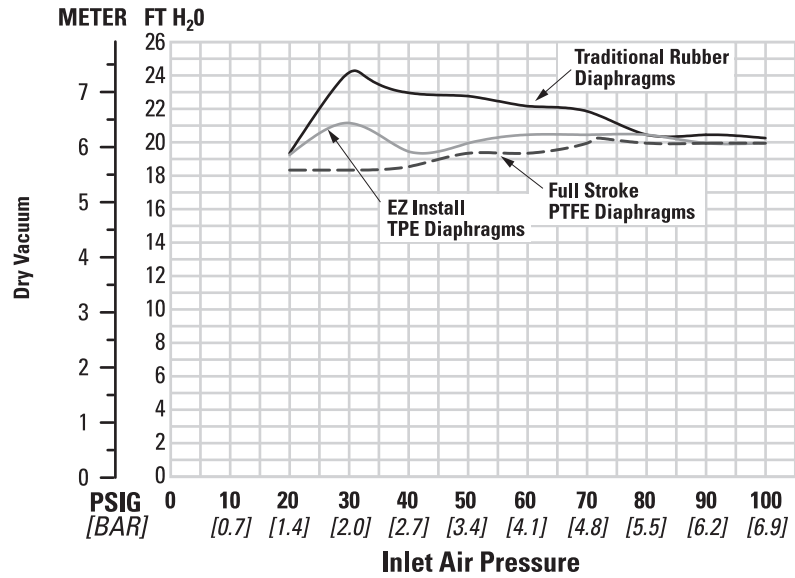

PS1500 STAINLESS STEEL SUCTION-LIFT CAPABILITY

Suction-lift curves are calibrated for pumps operating at 305 m (1,000') above sea level. This chart is meant to be a guide only. There are many variables that can affect your pump's operating characteristics. The number of intake and discharge elbows, viscosity of pumping fluid, elevation (atmospheric pressure) and pipe friction loss all affect the amount of suction lift your pump will attain.

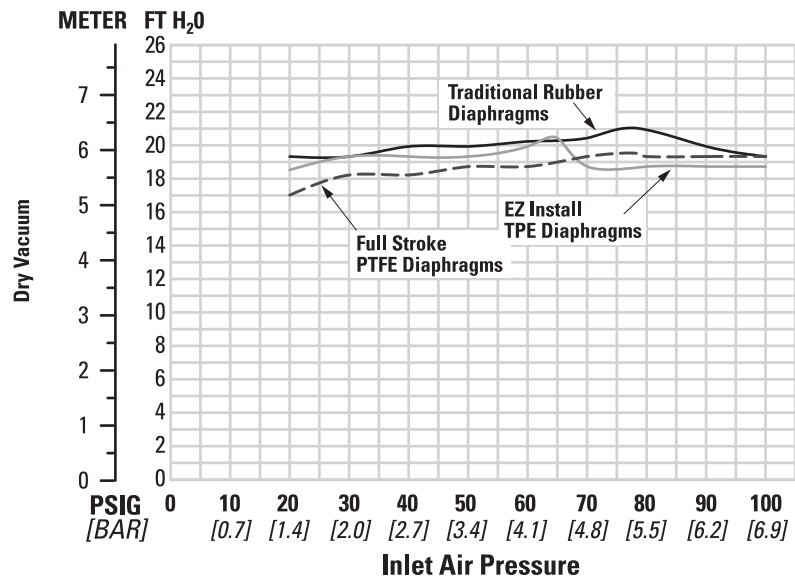

SUCTION-LIFT CURVES

PS1500 STAINLESS STEEL DROP-IN SUCTION-LIFT CAPABILITY

Suction-lift curves are calibrated for pumps operating at 305 m (1,000') above sea level. This chart is meant to be a guide only. There are many variables that can affect your pump's operating characteristics. The number of intake and discharge elbows, viscosity of pumping fluid, elevation (atmospheric pressure) and pipe friction loss all affect the amount of suction lift your pump will attain.

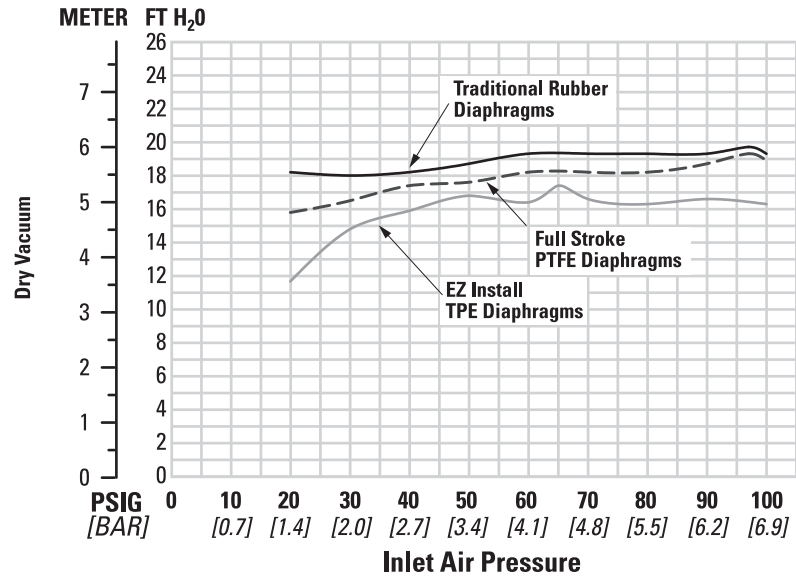



SUGGESTED INSTALLATION

Wilden pumps are designed to meet the performance requirements of even the most demanding pumping applications. They have been designed and manufactured to the highest standards and are available in a variety of liquid path materials to meet your chemical resistance needs. Refer to the performance section of this manual for an in-depth analysis of the performance characteristics of your pump. Wilden offers the widest variety of elastomer options in the industry to satisfy temperature, chemical compatibility, abrasion resistance and flex concerns.

The suction pipe size should be at least the equivalent or larger than the diameter size of the suction inlet on your Wilden pump. The suction hose must be non-collapsible, reinforced type as these pumps are capable of pulling a high vacuum. Discharge piping should also be the equivalent or larger than the diameter of the pump discharge which will help reduce friction losses. It is critical that all fittings and connections are airtight or a reduction or loss of pump suction capability will result.

INSTALLATION: Months of careful planning, study and selection efforts can result in unsatisfactory pump performance if installation details are left to chance.

Premature failure and long-term dissatisfaction can be avoided if reasonable care is exercised throughout the installation process.

LOCATION: Noise, safety and other logistical factors usually dictate where equipment will be situated on the production floor. Multiple installations with conflicting requirements can result in congestion of utility areas, leaving few choices for additional pumps.

Within the framework of these and other existing conditions, every pump should be located in such a way that six key factors are balanced against each other to maximum advantage.

ACCESS: First of all, the location should be accessible. If it's easy to reach the pump, maintenance personnel will have an easier time carrying out routine inspections and adjustments. Should major repairs become necessary, ease of access can play a key role in speeding the repair process and reducing total downtime.

AIR SUPPLY: Every pump location should have an air line large enough to supply the volume of air necessary to achieve the desired pumping rate. Use air pressure up to a maximum of 8.6 bar (125 psig) depending on pumping requirements.

For best results, the pumps should use a 5 μ (micron) air filter, needle valve and regulator. The use of an air filter before the pump will ensure that the majority of any pipeline contaminants will be eliminated.

SOLENOID OPERATION: When operation is controlled by a solenoid valve in the air line, three-way valves should be used. This valve allows trapped air between the valve and the pump to bleed off which improves pump performance. Pumping volume can be estimated by counting the number of strokes per minute and then multiplying the figure by the displacement per stroke.

MUFFLER: Sound levels are reduced below OSHA

specifications using the standard Wilden muffler. Other mufflers can be used to further reduce sound levels, but they usually reduce pump performance.

ELEVATION: Selecting a site that is well within the pump's dynamic lift capability will assure that loss-of-prime issues will be eliminated. In addition, pump efficiency can be adversely affected if proper attention is not given to site location.

PIPING: Final determination of the pump site should not be made until the piping challenges of each possible location have been evaluated. The impact of current and future installations should be considered ahead of time to make sure that inadvertent restrictions are not created for any remaining sites.

The best choice possible will be a site involving the shortest and straightest hook-up of suction and discharge piping. Unnecessary elbows, bends and fittings should be avoided. Pipe sizes should be selected to keep friction losses within practical limits. All piping should be supported independently of the pump. In addition, the piping should be aligned to avoid placing stress on the pump fittings.

Flexible hose can be installed to aid in absorbing the forces created by the natural reciprocating action of the pump. If the pump is to be bolted down to a solid location, a mounting pad placed between the pump and the foundation will assist in minimizing pump vibration. Flexible connections between the pump and rigid piping will also assist in minimizing pump vibration. If quick-closing valves are installed at any point in the discharge system, or if pulsation within a system becomes a problem, a surge suppressor (SD Equalizer[®]) should be installed to protect the pump, piping and gauges from surges and water hammer.

If the pump is to be used in a self-priming application, make sure that all connections are airtight and that the suction lift is within the model's ability. **NOTE:** Materials of construction and elastomer material have an effect on suction lift parameters. Please refer to the performance section for specifics.

When pumps are installed in applications involving flooded suction or suction head pressures, a gate valve should be installed in the suction line to permit closing of the line for pump service.

Pumps in service with a positive suction head are most efficient when inlet pressure is limited to 0.5–0.7 bar (7–10 psig). Premature diaphragm failure may occur if positive suction is 0.7 bar (10 psig) and higher.

SUBMERSIBLE APPLICATIONS: Pro-Flo[®] SHIFT pumps can be used for submersible applications when using the Pro-Flo[®] SHIFT single-point exhaust option. Pro-Flo X[™] and Turbo-Flo[®] Pumps are also available in a single-point exhaust (submersible) configuration.

NOTE: Pro-Flo[®] and Accu-Flo[™] pumps do not have a single-point exhaust option and are not submersible.

ALL WILDEN PUMPS ARE CAPABLE OF PASSING SOLIDS. A STRAINER SHOULD BE USED ON THE PUMP INTAKE TO ENSURE THAT THE PUMP'S RATED SOLIDS CAPACITY IS NOT EXCEEDED.

CAUTION: DO NOT EXCEED 8.6 BAR (125 PSIG) AIR SUPPLY PRESSURE.

SUGGESTED INSTALLATION

This illustration is a generic representation of an air-operated double-diaphragm pump.

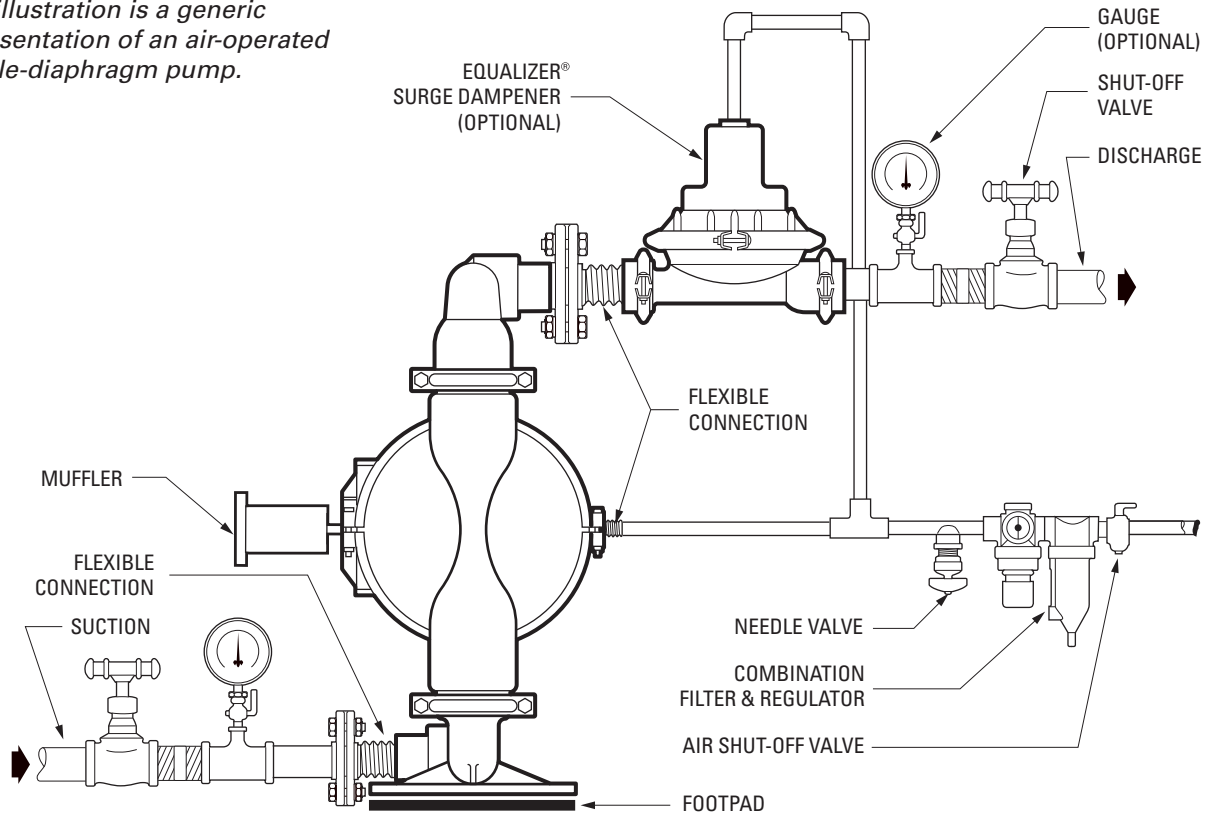

NOTE: In the event of a power failure, the shut-off valve should be closed, if the restarting of the pump is not desirable once power is regained.

AIR-OPERATED PUMPS: To stop the pump from operating in an emergency situation, simply close the

shut-off valve (user supplied) installed in the air supply line. A properly functioning valve will stop the air supply to the pump, therefore stopping output. This shut-off valve should be located far enough away from the pumping equipment such that it can be reached safely in an emergency situation.

SUGGESTED OPERATION & MAINTENANCE

OPERATION: The Pro-Flo® SHIFT pumps are pre-lubricated and do not require in-line lubrication. Additional lubrication will not damage the pump; however if the pump is heavily lubricated by an external source, the pump's internal lubrication may be washed away. If the pump is then moved to a non-lubricated location, it may need to be disassembled and re-lubricated as described in the ASSEMBLY/DISASSEMBLY INSTRUCTIONS.

Pump discharge rate can be controlled by limiting the volume and/or pressure of the air supply to the pump. An air regulator is used to regulate air pressure. A needle valve is used to regulate volume. Pump discharge rate can also be controlled by throttling the pump discharge by partially closing a valve in the discharge line of the pump. This action increases friction loss which reduces flow rate. (See Section 5.) This is useful when the need exists to control the pump from a remote location. When the pump discharge pressure equals or exceeds the air supply pressure, the pump will stop; no bypass or pressure relief valve is needed, and pump damage will not occur. The pump has reached a "deadhead" situation

and can be restarted by reducing the fluid discharge pressure or increasing the air inlet pressure. Wilden Pro-Flo® SHIFT pumps run solely on compressed air and do not generate heat; therefore, your process fluid temperature will not be affected.

MAINTENANCE AND INSPECTIONS: Since each application is unique, maintenance schedules may be different for every pump. Frequency of use, line pressure, viscosity and abrasiveness of process fluid all affect the parts life of a Wilden pump. Periodic inspections have been found to offer the best means for preventing unscheduled pump downtime. Personnel familiar with the pump's construction and service should be informed of any abnormalities that are detected during operation.

RECORDS: When service is required, a record should be made of all necessary repairs and replacements. Over a period of time, such records can become a valuable tool for predicting and preventing future maintenance problems and unscheduled downtime. In addition, accurate records make it possible to identify pumps that are poorly suited to their applications.

TROUBLESHOOTING

Pump will not run or runs slowly.

1. Ensure that the air inlet pressure is at least 0.4 bar (5 psig) above startup pressure and that the differential pressure (the difference between air inlet and liquid discharge pressures) is not less than 0.7 bar (10 psig).
2. Check air inlet filter for debris (see SUGGESTED INSTALLATION).
3. Check for extreme air leakage (blow by) which would indicate worn seals/bores in the air valve, pilot spool and main shaft.
4. Disassemble pump and check for obstructions in the air passageways or objects which would obstruct the movement of internal parts.
5. Check for sticking ball check valves. If material being pumped is not compatible with pump elastomers, swelling may occur. Replace ball check valves and seats with proper elastomers. Also, as the check valve balls wear out, they become smaller and can become stuck in the seats. In this case, replace balls and seats.
6. Check for broken inner piston which will cause the air valve spool to be unable to shift.
7. Remove plug from pilot spool exhaust.

Pump runs but little or no product flows.

1. Check for pump cavitation; slow pump speed down to allow thick material to flow into liquid chambers.
2. Verify that vacuum required to lift liquid is not

greater than the vapor pressure of the material being pumped (cavitation).

3. Check for sticking ball check valves. If material being pumped is not compatible with pump elastomers, swelling may occur. Replace ball check valves and seats with proper elastomers. Also, as the check valve balls wear out, they become smaller and can become stuck in the seats. In this case, replace balls and seats.

Pump air valve freezes.

1. Check for excessive moisture in compressed air. Either install a dryer or hot air generator for compressed air. Alternatively, a coalescing filter may be used to remove the water from the compressed air in some applications.

Air bubbles in pump discharge.

1. Check for ruptured diaphragm.
2. Check tightness of outer pistons (refer to Section 7).
3. Check tightness of fasteners and integrity of O-rings and seals, especially at intake manifold.
4. Ensure pipe connections are airtight.

Product comes out air exhaust.

1. Check for diaphragm rupture.
2. Check tightness of outer pistons to shaft.



PUMP DISASSEMBLY

Tools Required:

- Appropriate-sized Wrench
- Adjustable Wrench
- Vise equipped w/ soft jaws (such as plywood, plastic or other suitable material)

CAUTION: Before any maintenance or repair is attempted, the compressed air line to the pump should be disconnected and all air pressure allowed to bleed from the pump. Disconnect all intake, discharge and air lines. Drain the pump by turning it upside down and allowing any fluid to flow into a suitable container. Be aware of any hazardous effects of contact with your process fluid.

NOTE: The model photographed is an aluminum PS800 51 mm (2") pump. Your specific pump model may vary from configuration shown.

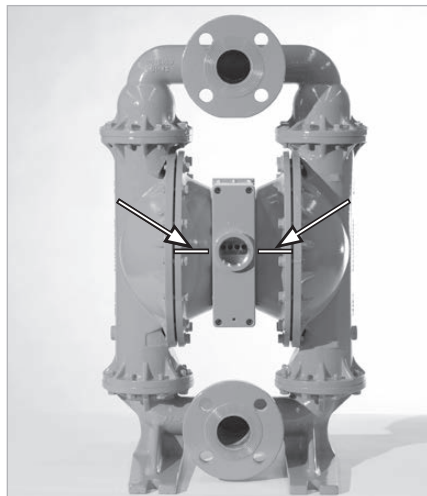
**Step 1**

Before starting disassembly, mark a line from each liquid chamber to its corresponding air chamber. This line will assist in proper alignment during reassembly.

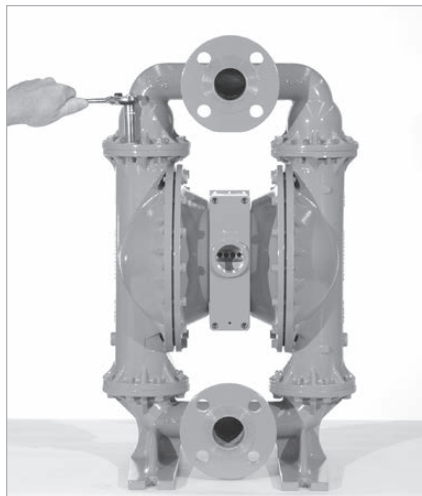
**Step 2**

Using the appropriate-sized wrench for your pump size, loosen the discharge manifold from the liquid chambers.

**Step 3**

Lift the discharge manifold to expose discharge valve balls and valve seats. Inspect ball cage area of manifold for excessive wear or damage.

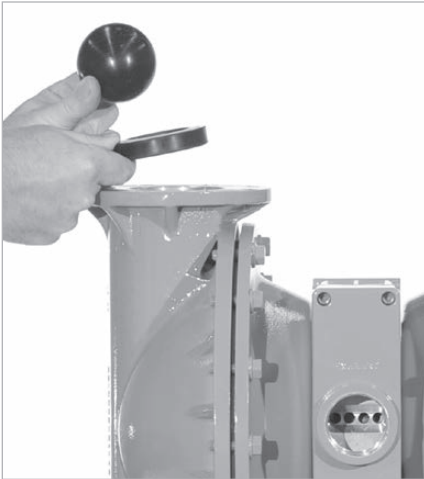

Step 4

Remove the discharge valve balls and valve seats from the liquid chambers and inspect for nicks, gouges, chemical attack or abrasive wear. Replace worn parts with genuine Wilden parts for reliable performance.

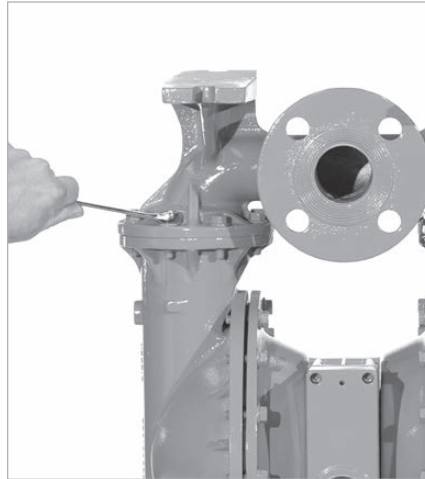

Step 5

Using the appropriate-sized wrench, loosen the inlet manifold from the liquid chambers. Note: Inverting the pump will facilitate removal of inlet manifold.

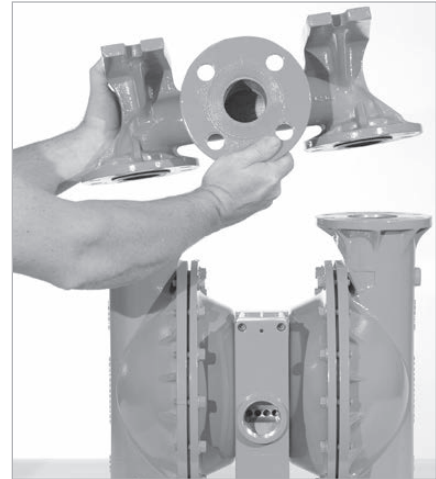

Step 6

Lift away inlet manifold from liquid chambers and center section.

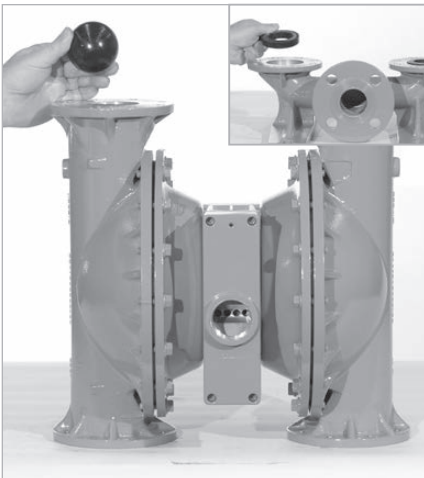

Step 7

Remove the inlet valve balls and valve seats from the inlet manifold and liquid chambers and inspect for nicks, gouges, chemical attack or abrasive wear.

NOTE: Replace worn parts with genuine Wilden parts for reliable performance.

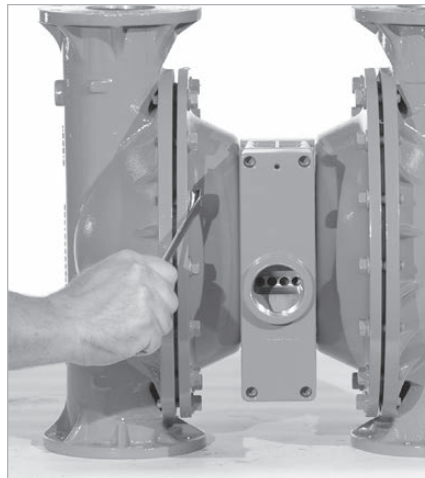

Step 8

Using the appropriate-sized wrench, remove the fasteners from the liquid chamber and center section.



Step 9

Lift away liquid chamber to expose the diaphragm and outer piston. Rotate center section and remove the opposite liquid chamber.

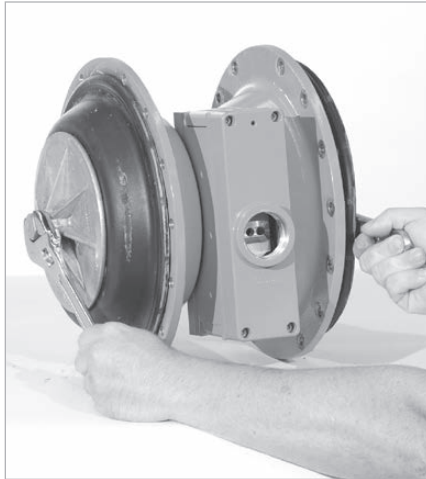

Step 10

Using two adjustable wrenches, turn each diaphragm in a counterclockwise direction to loosen the outer pistons. Inspect diaphragm assembly and shaft for signs of wear or chemical attack. Replace all worn parts with genuine Wilden parts for reliable performance.



Step 11

Inspect the diaphragm assembly for wear, damage or chemical attack. Replace any damaged components with genuine Wilden parts for reliable performance.

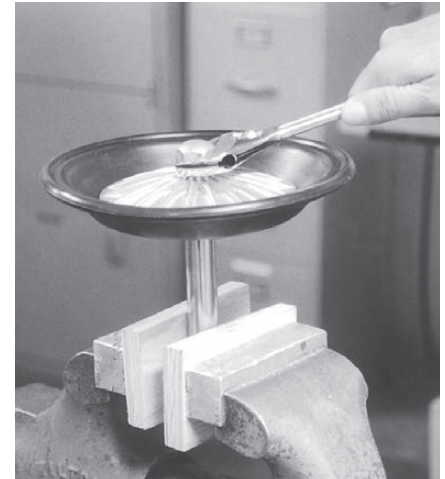

Step 12

To remove diaphragm assembly from shaft, secure shaft with soft jaws (aluminum, plastic or plywood) to ensure the shaft is not damaged. Using an adjustable wrench, remove the diaphragm assembly from the shaft.

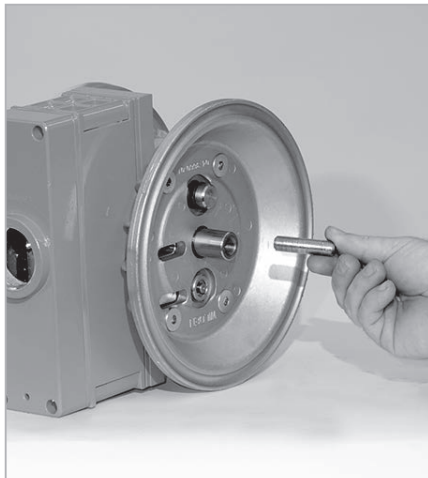

Step 13

Remove outer piston and stud if equipped. Inspect for wear and replace if necessary.

AIR VALVE / CENTER SECTION DISASSEMBLY

Tools Required:

- Appropriate-sized Wrench
- Snap Ring Pliers
- O-Ring Pick

CAUTION: Before any maintenance or repair is attempted, the compressed air line to the pump should be disconnected and all air pressure allowed to bleed from the pump. Disconnect all intake, discharge and air lines. Drain the pump by turning it upside down and allowing any fluid to flow into a suitable container. Be aware of hazardous effects of contact with your process fluid.

The Wilden Pro-Flo® SHIFT metal pumps utilize a revolutionary Pro-Flo® air distribution system. Proprietary composite seals reduce the coefficient of friction and allow the Pro-Flo® SHIFT to run lube-free. Constructed of aluminum, the Pro-Flo® air distribution system is designed to perform in on/off, non-freezing, non-stalling, tough duty applications.



Step 1

Using a pair of snap ring pliers, remove the snap ring from pilot sleeve.



Step 2

Using an O-ring pick, remove O-ring from modulator spool.



Step 3

Using the appropriate-sized wrench, loosen and remove the fasteners that attach the air chamber to center section.

AIR VALVE / CENTER SECTION DISASSEMBLY

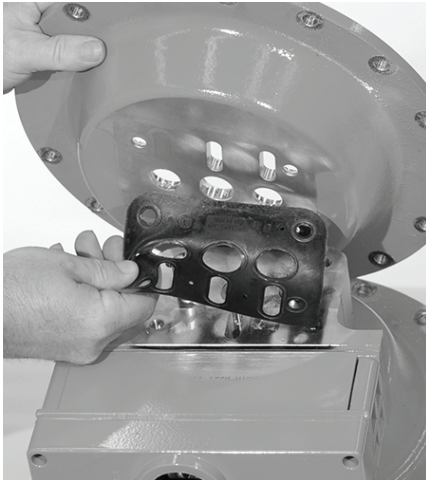

Step 4

Lift away air chamber from center section and remove center block gasket. Replace gasket if necessary.



Step 5

Turn assembly over and remove the pilot spool sleeve from the center section.



Step 6

Using an O-ring pick, gently remove the O-ring from the opposite side of the dimpled end of the pilot spool.



Step 7

Gently remove the pilot spool from the sleeve and inspect for nicks, wear or damage. Replace the pilot spool assembly or sleeve O-rings if necessary. During reassembly, never insert the dimpled end of the pilot spool first, this will damage the single urethane O-ring by passing it over the ports in the pilot sleeve.

NOTE: Seals should not be removed from the assembly. Seals are not sold separately.



Step 8

Remove modulator spool from center section. Check for wear to spool or O-rings and replace if necessary.



Step 9

Using the appropriate-sized wrench, loosen the fasteners and lift away remaining air chamber and center block gasket from center section. Replace gasket if necessary.

AIR VALVE / CENTER SECTION DISASSEMBLY

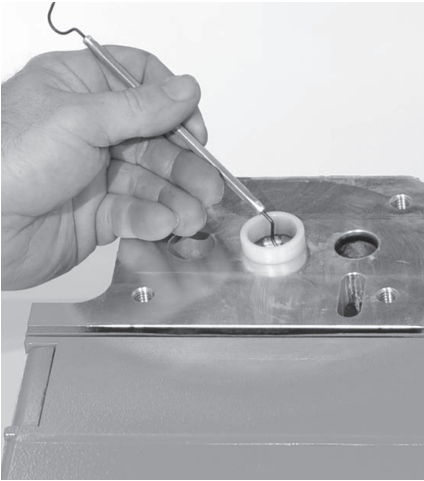

Step 10

Using an O-ring pick, remove the two (2) shaft bushings from center block. Inspect and replace if necessary. Using an O-ring pick, gently remove the two (2) Glyd™ rings from the center block. Inspect and replace if necessary.

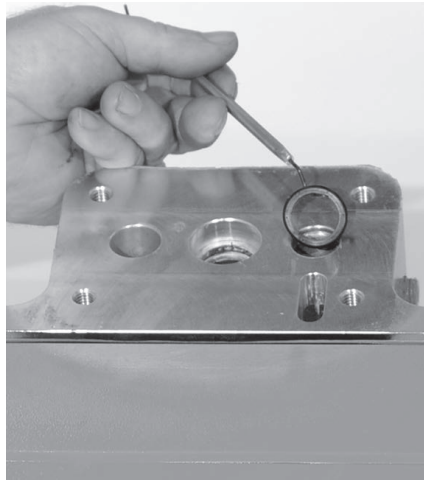

Step 11

Using an O-ring pick, remove the two (2) Glyd™ rings from modulator spool bore. Inspect and replace if necessary.



Step 12

Using an appropriate-sized wrench, remove the pilot exhaust muffer. Inspect for damage or contamination and replace if necessary.



Step 13

Using an appropriate-sized hex wrench, loosen and remove the four (4) air valve bolts from center section assembly.

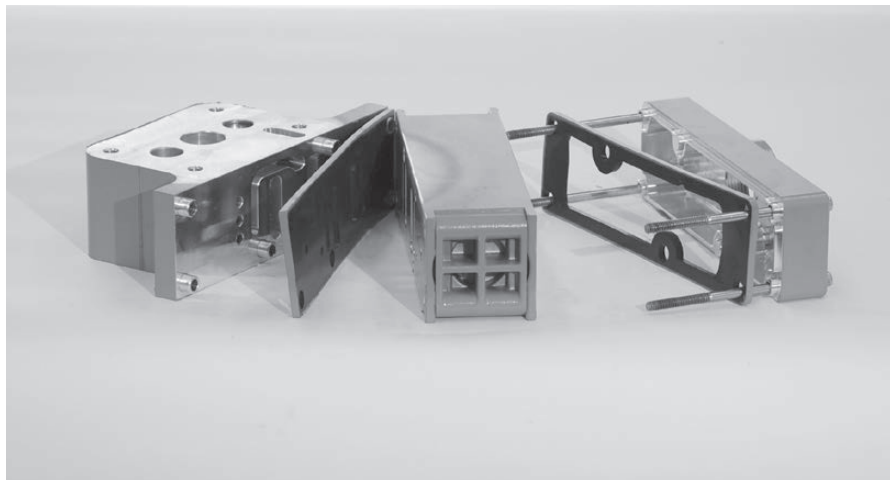

Step 14

Lift away muffer plate and muffer plate gasket from center block. Inspect for wear and replace if necessary. Lift away the air valve assembly and remove air valve gasket. Inspect the gasket and replace if necessary.

AIR VALVE / CENTER SECTION DISASSEMBLY

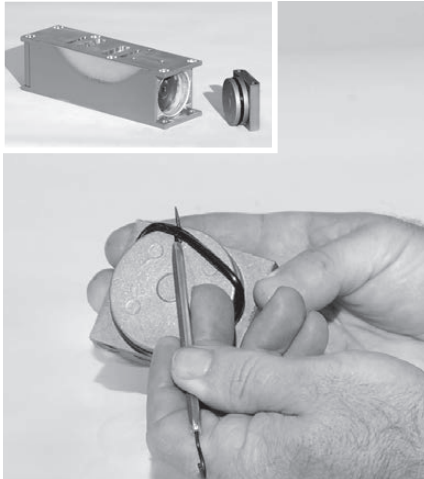

Step 15

Remove air valve end cap to expose air valve spool by lifting up on end cap. Inspect O-ring on end cap using an O-ring pick. Replace O-ring(s) if necessary. NOTE: The Pro-Flo® SHIFT air valve incorporates an end cap at both ends of the air valve.

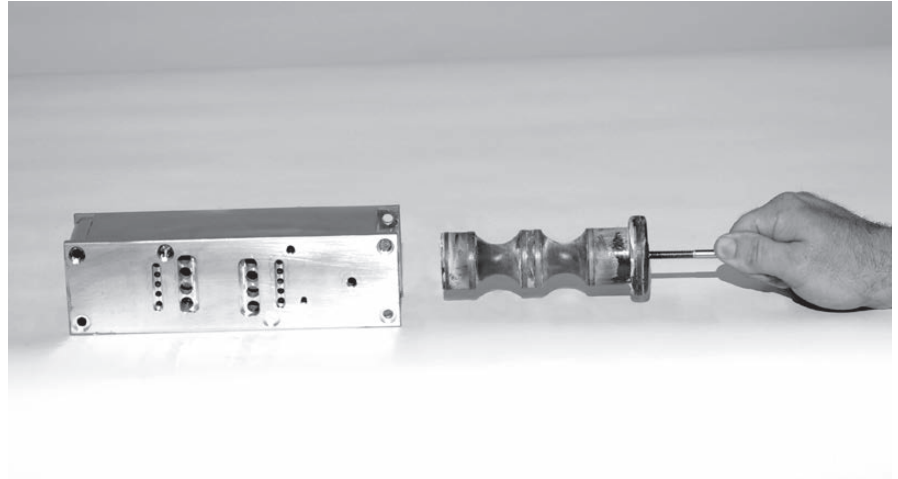

Step 16

Remove the air valve spool from the air valve body by threading one air valve bolt into the end of the air valve spool and gently sliding the spool out of the air valve body. Inspect seals for signs of wear and replace the entire air valve assembly if necessary. Re-insert the spool immediately into air valve body after inspection as the seals expand and cannot be reinserted after a length of time.

NOTE: Seals should not be removed from the assembly. Seals are not sold separately.

SINGLE-POINT EXHAUST PRO-FLO® SHIFT

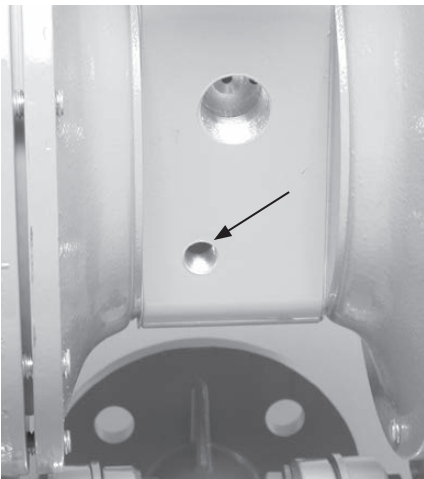

Step 1

Remove pilot exhaust muffler in pilot bleed port located at the front of the center block. Install 1/4" NPT pipe plug (00-7010-08) into bleed port.



Standard



Single-Point Exhaust

Step 2

Next, install an optional single-point exhaust air valve gasket (04-2628-52). The single-point air valve gasket can be purchased as a spare part or included with the purchase of a new Pro-Flo® SHIFT pump.

REASSEMBLY HINTS & TIPS

ASSEMBLY:

Upon performing applicable maintenance to the air distribution system, the pump can now be reassembled. Please refer to the disassembly instructions for photos and parts placement. To reassemble the pump, follow the disassembly instructions in reverse order. The air distribution system needs to be assembled first, then the diaphragms and finally the wetted path. Please find the applicable torque specifications on this page. The following tips will assist in the assembly process.

- Lubricate air valve bore, center section shaft and pilot spool bore with NLGI grade 2 white EP bearing grease or equivalent.
- Clean the inside of the center section shaft bore to ensure no damage is done to new shaft seals.
- A small amount of NLGI grade 2 white EP bearing grease can be applied to the muffler and air valve gaskets to locate gaskets during assembly.
- Make sure that the exhaust port on the muffler plate is centered between the two exhaust ports on the center section.
- Stainless bolts should be lubed to reduce the possibility of seizing during tightening.

PRO-FLO® SHIFT MAXIMUM TORQUE SPECIFICATIONS

Description of Part	Torque
Air Valve	13.6 N•m (120 in-lbs)
Air Chamber/Center Block	27.1 N•m (20 ft-lbs)
Inner Piston Ring	19.0 N•m (14 ft-lbs)
Outer Pistons, Rubber & PTFE	135.6 N•m (100 ft-lbs)

SHAFT SEAL INSTALLATION:

PRE-INSTALLATION

- Once all of the old seals have been removed, the inside of the bushing should be cleaned to ensure no debris is left that may cause premature damage to the new seals.

INSTALLATION

The following tools can be used to aid in the installation of the new seals:

Needle Nose Pliers
Phillips Screwdriver
Electrical Tape

- Wrap electrical tape around each leg of the needle nose pliers (heat shrink tubing may also be used). This is done to prevent damaging the inside surface of the new seal.
- With a new seal in hand, place the two legs of the needle nose pliers inside the seal ring. (See Figure A.)
- Open the pliers as wide as the seal diameter will allow, then with two fingers pull down on the top portion of the seal to form kidney bean shape. (See Figure B.)
- Lightly clamp the pliers together to hold the seal into the kidney shape. Be sure to pull the seal into as tight of a kidney shape as possible, this will allow the seal to travel down the bushing bore with greater ease.
- With the seal clamped in the pliers, insert the seal into the bushing bore and position the bottom of the seal into the correct groove. Once the bottom of the seal is seated in the groove, release the clamp pressure on the pliers. This will allow the seal to partially snap back to its original shape.
- After the pliers are removed, you will notice a slight bump in the seal shape. Before the seal can be properly resized, the bump in the seal should be removed as much as possible. This can be done with either the Phillips screwdriver or your finger. With either the side of the screwdriver or your finger, apply light pressure to the peak of the bump. This pressure will cause the bump to be almost completely eliminated.
- Lubricate the edge of the shaft with NLGI grade 2 white EP bearing grease.
- Slowly insert the center shaft with a rotating motion. This will complete the resizing of the seal.
- Perform these steps for the remaining seal.

Figure A

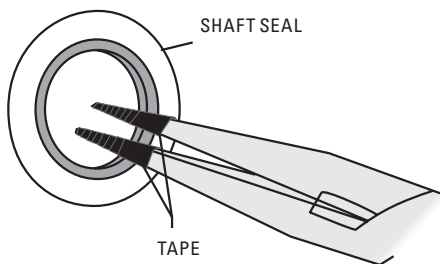
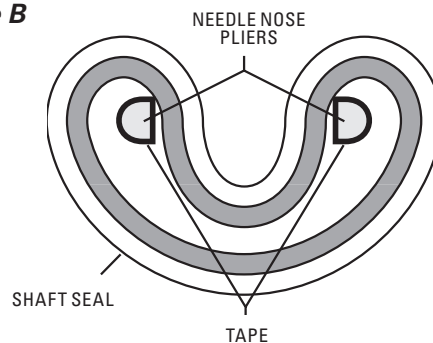

Figure B



NOTES



EXPLODED VIEW & PARTS LISTING

PS1500 ALUMINUM

EXPLODED VIEW

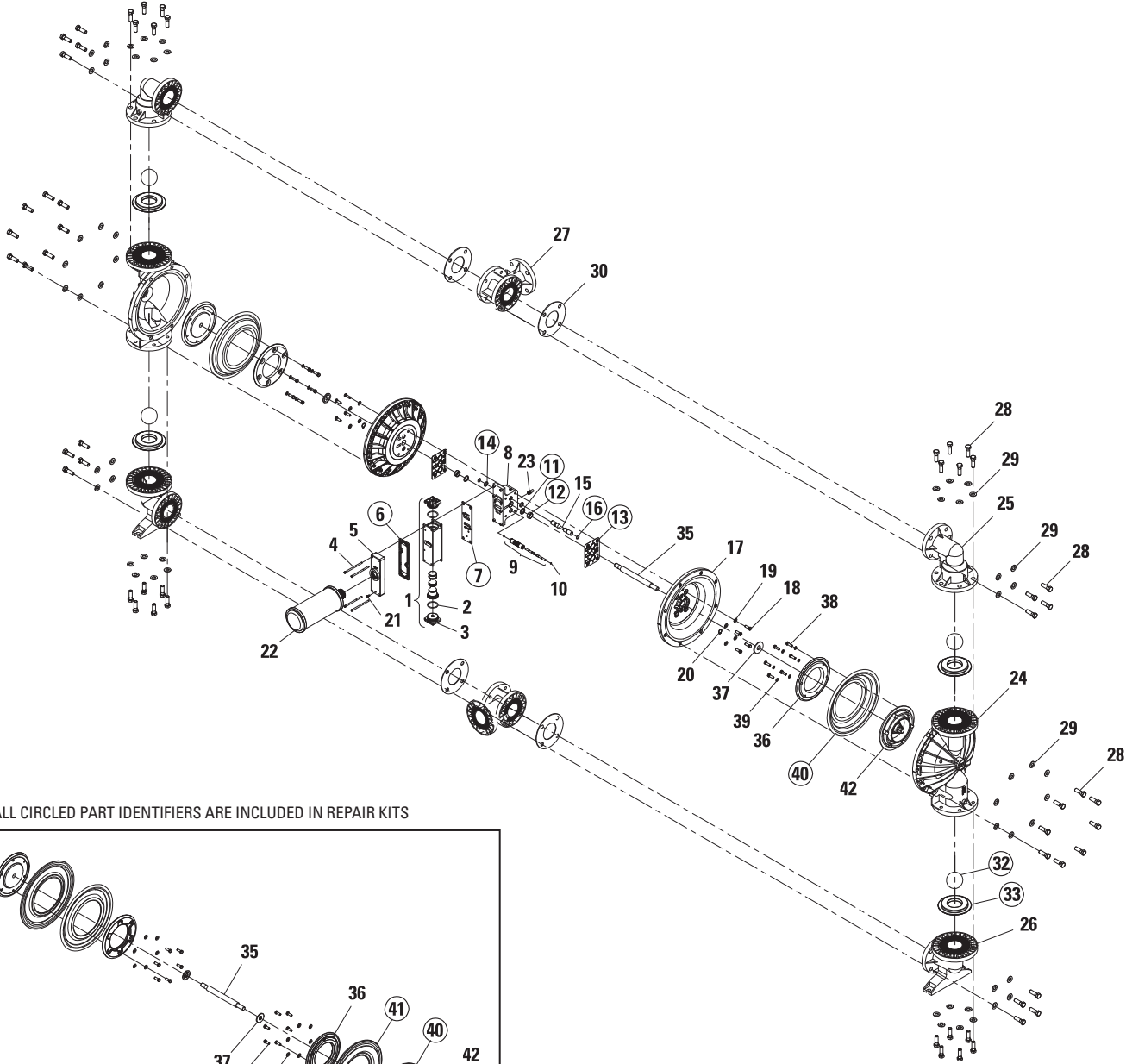

ALL CIRCLED PART IDENTIFIERS ARE INCLUDED IN REPAIR KITS

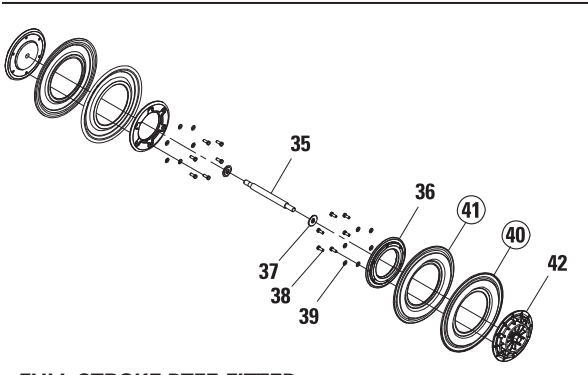

FULL STROKE PTFE-FITTED

LW0039 REV. B

EXPLODED VIEW & PARTS LISTING

PS1500 ALUMINUM

PARTS LISTING

Item	Description	Qty.	XPS1500/AAAA/ P/N
AIR DISTRIBUTION COMPONENTS			
1	Air Valve Assembly, Pro-Flo® SHIFT¹	1	04-2039-01
2	O-Ring (-225), End Cap (Ø1.859" x Ø.139")	2	04-2390-52-700
3	End Cap	2	04-2340-01
4	Screw, SHC, Air Valve (1/4" -20 x 4-1/2")	4	01-6000-03
5	Muffler Plate, Pro-Flo SHIFT™	1	04-3189-01
6	Gasket, Muffler Plate, Pro-Flo® SHIFT	1	04-3509-52
7	Gasket, Air Valve, Pro-Flo® SHIFT	1	04-2629-52
8	Center Block Assembly, Pro-Flo® SHIFT™ ²	1	15-3129-01
9	Pilot Sleeve Assembly	1	15-3884-99
10	O-Ring (-009), Pilot Spool Retaining (Ø.208" x Ø.070")	2	04-2650-49-700
11	Seal, Shaft	2	15-3210-55-225
12	Bushing, Shaft	2	15-3306-13
13	Gasket, Center Block Pro-Flo V™	2	04-3529-52
14	Seal, Air Control Spool	2	02-3210-55-225
15	Air Control Spool	1	15-3859-03
16	O-Ring (-114), Air Control Spool Retaining (Ø.612" x Ø.103")	2	04-3879-50
17	Air Chamber, Pro-Flo V™	2	15-3691-01
18	Screw, HHC (3/8" -16 x 1-1/8")	8	15-6130-08
19	Washer, Flat (Ø.406" x Ø.812" x .065")	8	15-6740-08-50
20	Retaining Ring	2	04-3890-03
21	Grounding Screw, (10-32 x .50") Self Tapping	1	04-6345-08
22	Muffler 1-1/2" NPT	1	04-3518-99R
23	Muffler 1/4" NPT	1	04-3240-07
WETTED PATH COMPONENTS			
24	Liquid Chamber, Bolted	2	15-4980-01
25	Discharge Elbow, Bolted	2	15-5250-01
26	Inlet Elbow, Bolted	2	15-5210-01
27	T-Section, Bolted (ANSI)	2	15-5180-01
	T-Section, Bolted (DIN)	2	15-5185-01
28	Screw, HHC (5/8" -11 x 2")	56	15-6180-08
29	Washer, Flat (Ø.656" x Ø1.312" x .095")	56	15-6732-08
GASKETS/VALVE BALLS/VALVE SEATS/VALVE O-RINGS			
30	T-Section Gasket	4	*
31	Manifold Gasket, PTFE Fitted (not shown)	4	15-1405-55
32	Ball, Valve	4	*
33	Seat, Valve	4	*
34	O-Ring (-250), Valve Seat PTFE Fitted (Ø4.984" x Ø.139") (Not Shown)	4	15-1205-55
FULL STROKE RUBBER/TPE/PTFE COMPONENTS			
35	Shaft	1	15-3805-09
36	Piston, Inner	2	15-3700-01
37	Washer, Inner Piston Back-up	2	15-6850-08
38	Inner Piston Screw, HHC (3/8" -16 x 1-1/8")	12	15-6130-08
39	Inner Piston Washer (Ø.406" x Ø.812" x .065")	12	15-6740-08-50
40	Diaphragm, Primary	2	*
41	Diaphragm, Back-Up	2	*
42	Piston, Outer	2	15-4550-01

*See elastomer chart - Section 9

¹Air Valve Assembly includes items 2 and 3.

²Metal Center Block Assembly includes item 11, 12, 14, 15 and 16.

All boldface items are primary wear parts

LW0048 Rev. E

EXPLODED VIEW & PARTS LISTING

PS1500 STAINLESS STEEL

EXPLODED VIEW

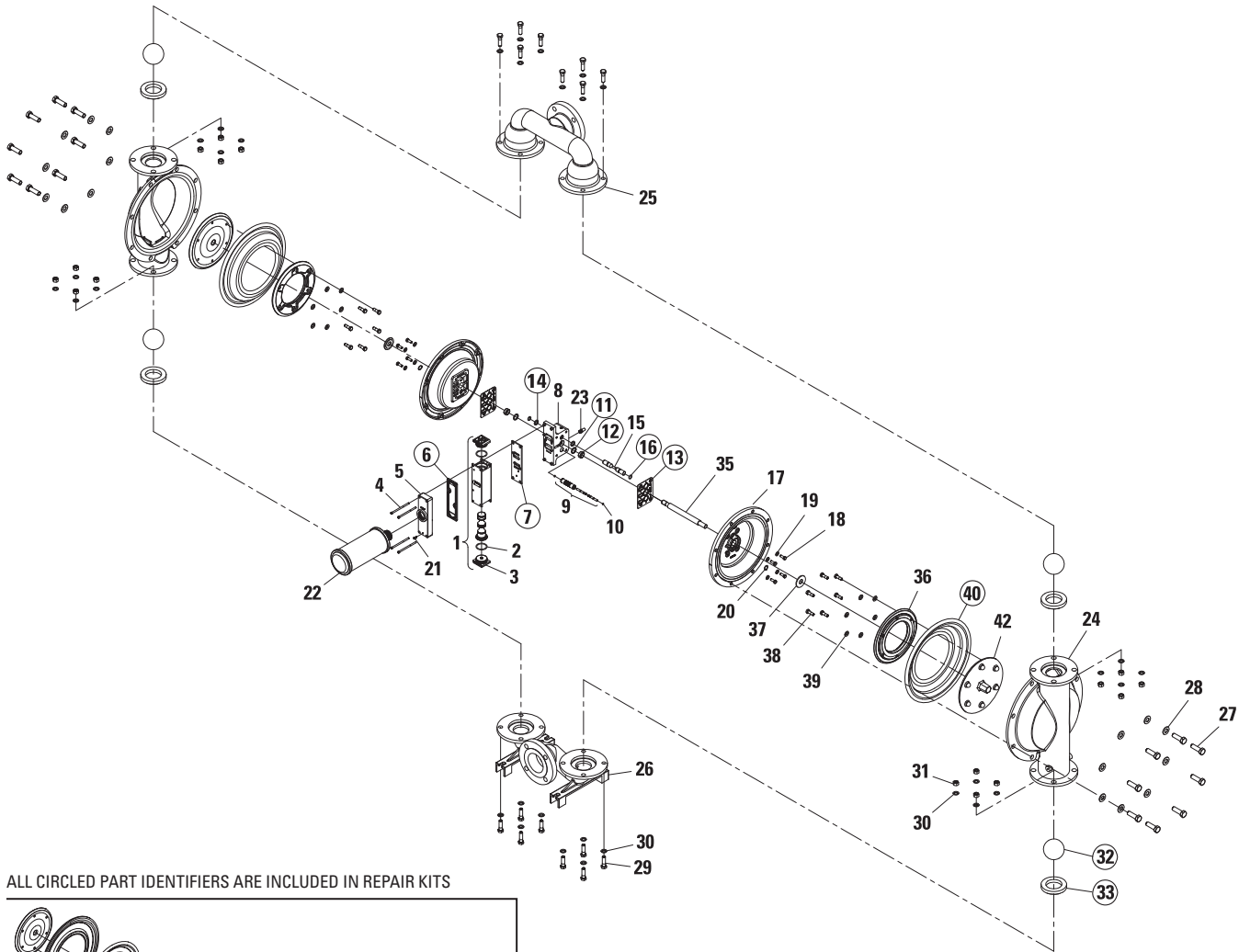

ALL CIRCLED PART IDENTIFIERS ARE INCLUDED IN REPAIR KITS

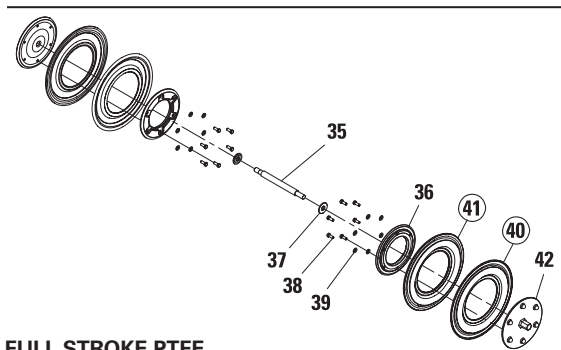

FULL STROKE PTFE

LW0040 REV. B

EXPLODED VIEW & PARTS LISTING

PS1500 STAINLESS STEEL

PARTS LISTING

Item	Description	Qty.	XPS1500/SSAAA/ P/N	XPS1500/HHAAA/ P/N
AIR DISTRIBUTION COMPONENTS				
1	Air Valve Assembly, Pro-Flo® SHIFT ¹	1	04-2039-01	04-2039-01
2	O-Ring (-225), End Cap (Ø1.859" x Ø.139")	2	04-2390-52-700	04-2390-52-700
3	End Cap	2	04-2340-01	04-2340-01
4	Screw, SHC, Air Valve (1/4" -20 x 4-1/2")	4	01-6000-03	01-6000-03
5	Muffler Plate, Pro-Flo® SHIFT	1	04-3189-01	04-3189-01
6	Gasket, Muffler Plate, Pro-Flo® SHIFT	1	04-3509-52	04-3509-52
7	Gasket, Air Valve, Pro-Flo® SHIFT	1	04-2629-52	04-2629-52
8	Center Block Assembly, Pro-Flo® SHIFT ²	1	15-3129-01	15-3129-01
9	Pilot Sleeve Assembly	1	15-3884-99	15-3884-99
10	O-Ring (-009), Pilot Spool Retaining (Ø.208" x Ø.070")	2	04-2650-49-700	04-2650-49-700
11	Seal, Shaft	2	15-3210-55-225	15-3210-55-225
12	Bushing, Shaft	2	15-3306-13	15-3306-13
13	Gasket, Center Block Pro-Flo V™	2	04-3529-52	04-3529-52
14	Seal, Air Control Spool	2	02-3210-55-225	02-3210-55-225
15	Air Control Spool	1	15-3859-03	15-3859-03
16	O-Ring (-114), Air Control Spool Retaining (Ø.612" x Ø.103")	2	04-3879-50	04-3879-50
17	Air Chamber, Pro-Flo V™	2	15-3691-01	15-3691-01
18	Screw, HHC (3/8" -16 x 1-1/8")	8	15-6130-08	15-6130-08
19	Washer, Flat (Ø.406" x Ø.812" x .065")	8	15-6740-08-50	15-6740-08-50
20	Retaining Ring	2	04-3890-03	04-3890-03
21	Grounding Screw, (10-32 x .50") Self Tapping	1	04-6345-08	04-6345-08
22	Muffler 1-1/2" NPT	1	04-3518-99R	04-3518-99R
23	Muffler 1/4" NPT	1	04-3240-07	04-3240-07
WETTED PATH COMPONENTS				
24	Liquid Chamber, Bolted	2	15-5005-03	15-5005-04
25	Manifold, Discharge (ANSI)	1	15-5030-03	15-5030-04
	Manifold, Discharge (DIN)	1	15-5031-03	15-5031-04
26	Manifold, Inlet (ANSI)	1	15-5090-03	15-5090-04
	Manifold, Inlet (DIN)	1	15-5091-03	15-5091-04
27	Screw, HHC (5/8" -11 x 2")	16	15-6180-03	15-6180-03
28	Spring, Disk (5/8")	16	15-6820-03	15-6820-03
29	Screw, HHC (1/2" -13 x 1-3/4")	16	15-6182-03	15-6182-03
30	Spring, Disk (1/2")	32	15-6810-03	15-6810-03
31	Hex Nut (1/2" -13)	16	15-6420-03	15-6420-03
GASKETS/VALVE BALLS/VALVE SEATS/VALVE O-RINGS				
32	Ball, Valve	4	*	*
33	Seat, Valve	4	*	*
34	O-Ring (-342), Valve Seat PTFE Fitted (Ø3.600" x Ø.210") (Not Shown)	4	15-1200-55	15-1200-55
FULL STROKE RUBBER/TPE/PTFE COMPONENTS				
35	Shaft	1	15-3805-09	15-3805-09
36	Piston, Inner	2	15-3700-01	15-3700-01
37	Washer, Inner Piston Back-up	2	15-6850-08	15-6850-08
38	Screw, HHC (3/8" -16 x 1-1/8")	12	15-6130-08	15-6130-08
39	Washer (Ø.406" x Ø.812" x .065")	12	15-6740-08-50	15-6740-08-50
40	Diaphragm, Primary	2	*	*
41	Diaphragm, Back-Up	2	*	*
42	Piston, Outer	2	15-4550-03	15-4550-04

*See elastomer chart - Section 9

¹Air Valve Assembly includes items 2 and 3

²Metal Center Block Assembly includes item 11, 12, 14, 15 and 16

All boldface items are primary wear parts

LW0050 Rev. F

EXPLODED VIEW & PARTS LISTING

PS1500 ALUMINUM DROP-IN

EXPLODED VIEW

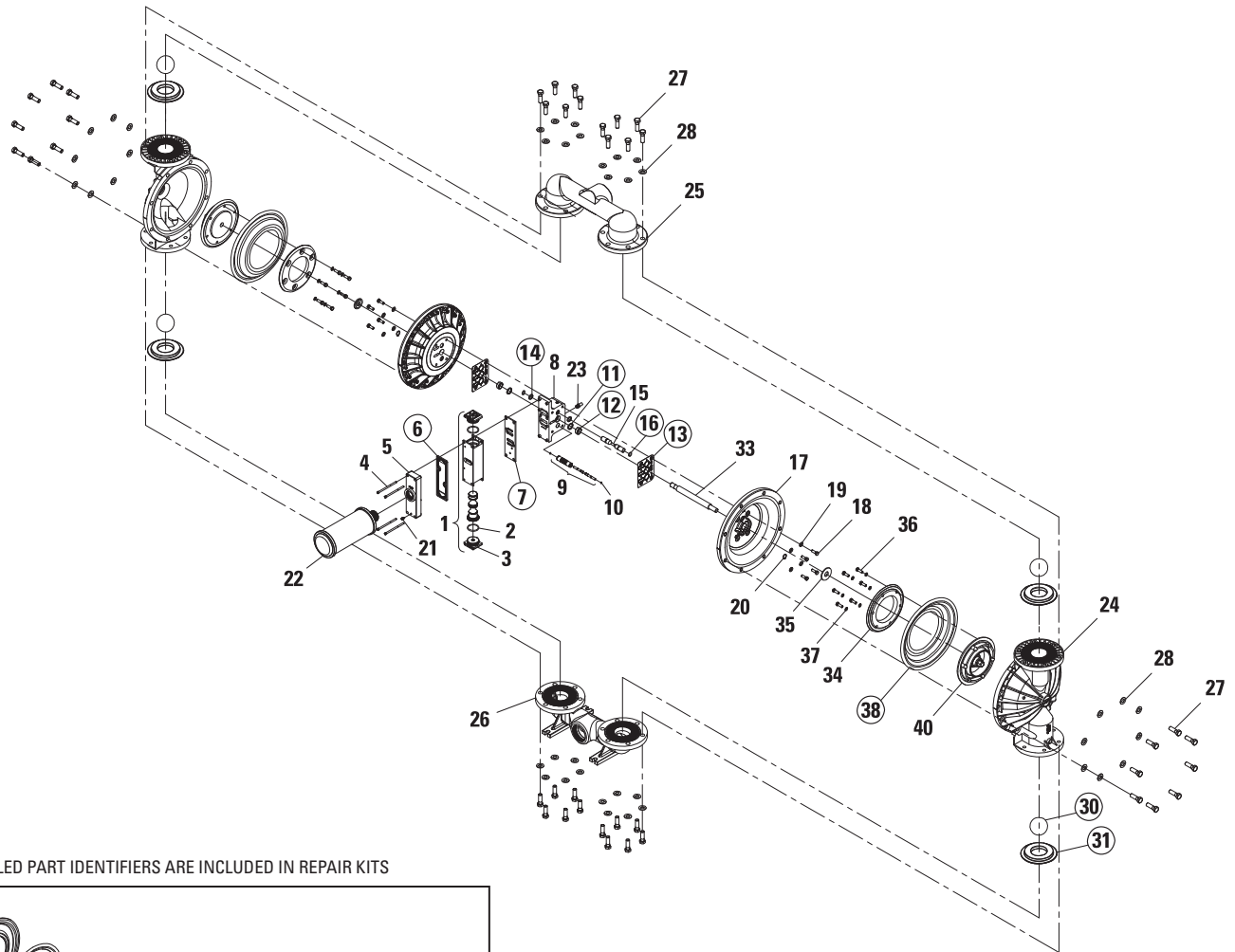

ALL CIRCLED PART IDENTIFIERS ARE INCLUDED IN REPAIR KITS

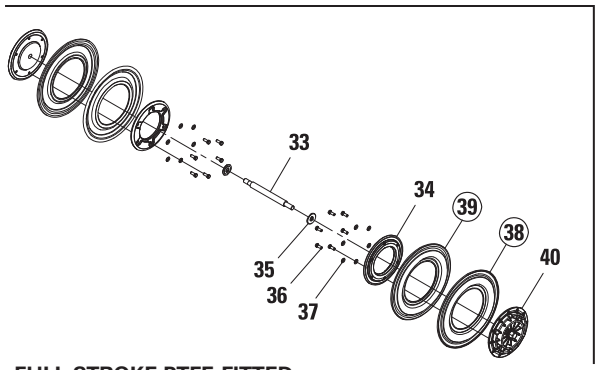

FULL STROKE PTFE-FITTED

LW0042 REV. B

EXPLODED VIEW & PARTS LISTING

PS1500 ALUMINUM DROP-IN

PARTS LISTING

Item	Description	Qty.	XPS1500/AAAAA/.../0877 P/N
AIR DISTRIBUTION COMPONENTS			
1	Air Valve Assembly, Pro-Flo® SHIFT ¹	1	04-2039-01
2	O-Ring (-225), End Cap (Ø1.859" x Ø.139")	2	04-2390-52-700
3	End Cap	2	04-2340-01
4	Screw, SHC, Air Valve (1/4"-20 x 4-1/2")	4	01-6000-03
5	Muffler Plate, Pro-Flo® SHIFT	1	04-3189-01
6	Gasket, Muffler Plate, Pro-Flo® SHIFT	1	04-3509-52
7	Gasket, Air Valve, Pro-Flo® SHIFT	1	04-2629-52
8	Center Block Assembly, Pro-Flo® SHIFT ²	1	15-3129-01
9	Pilot Sleeve Assembly	1	15-3884-99
10	O-Ring (-009), Pilot Spool Retaining (Ø.208" x Ø.070")	2	04-2650-49-700
11	Seal, Shaft	2	15-3210-55-225
12	Bushing, Shaft	2	15-3306-13
13	Gasket, Center Block Pro-Flo V™	2	04-3529-52
14	Seal, Air Control Spool	2	02-3210-55-225
15	Air Control Spool	1	15-3859-03
16	O-Ring (-114), Air Control Spool Retaining (Ø.612" x Ø.103")	2	04-3879-50
17	Air Chamber, Pro-Flo V™	2	15-3691-01
18	Screw, HHC (3/8"-16 x 1-1/8")	8	15-6130-08
19	Washer, Flat (Ø.406" x Ø.812" x .065")	8	15-6740-08-50
20	Retaining Ring	2	04-3890-03
21	Grounding Screw, (10-32 x .50") Self Tapping	1	04-6345-08
22	Muffler 1-1/2" NPT	1	04-3518-99R
23	Muffler 1/4" NPT	1	04-3240-07
WETTED PATH COMPONENTS			
24	Liquid Chamber, Bolted	2	15-4980-01
25	Manifold, Discharge (NPT)	1	15-5035-01
	Manifold, Discharge (BSPT)	1	15-5036-01
26	Manifold, Inlet (NPT)	1	15-5095-01
	Manifold, Inlet (BSPT)	1	15-5096-01
27	Screw, HHC (5/8"-11 x 2")	40	15-6180-08
28	Washer, Flat (Ø.656" x Ø.1312" x .095")	40	15-6732-08
GASKETS/VALVE BALLS/VALVE SEATS/VALVE O-RINGS			
29	Manifold Gasket, PTFE Fitted (not shown)	4	15-1405-55
30	Ball, Valve	4	*
31	Seat, Valve	4	*
32	O-Ring (-250), Valve Seat PTFE Fitted (Ø4.984" x Ø.139") (Not Shown)	4	15-1205-55
FULL STROKE RUBBER/TPE/PTFE COMPONENTS			
33	Shaft	1	15-3805-09
34	Piston, Inner	2	15-3700-01
35	Washer, Inner Piston Back-up	2	15-6850-08
36	Inner Piston Screw, HHC (3/8"-16 x 1-1/8")	12	15-6130-08
37	Inner Piston Washer (Ø.406" x Ø.812" x .065")	12	15-6740-08-50
38	Diaphragm, Primary	2	*
39	Diaphragm, Back-Up	2	*
40	Piston, Outer	2	15-4550-01

LW0049 Rev. E

*See elastomer chart - Section 9

¹Air Valve Assembly includes items 2 and 3

²Metal Center Block Assembly includes item 11, 12, 14, 15 and 16

All boldface items are primary wear parts

EXPLODED VIEW & PARTS LISTING

PS1500 STAINLESS STEEL DROP-IN

EXPLODED VIEW

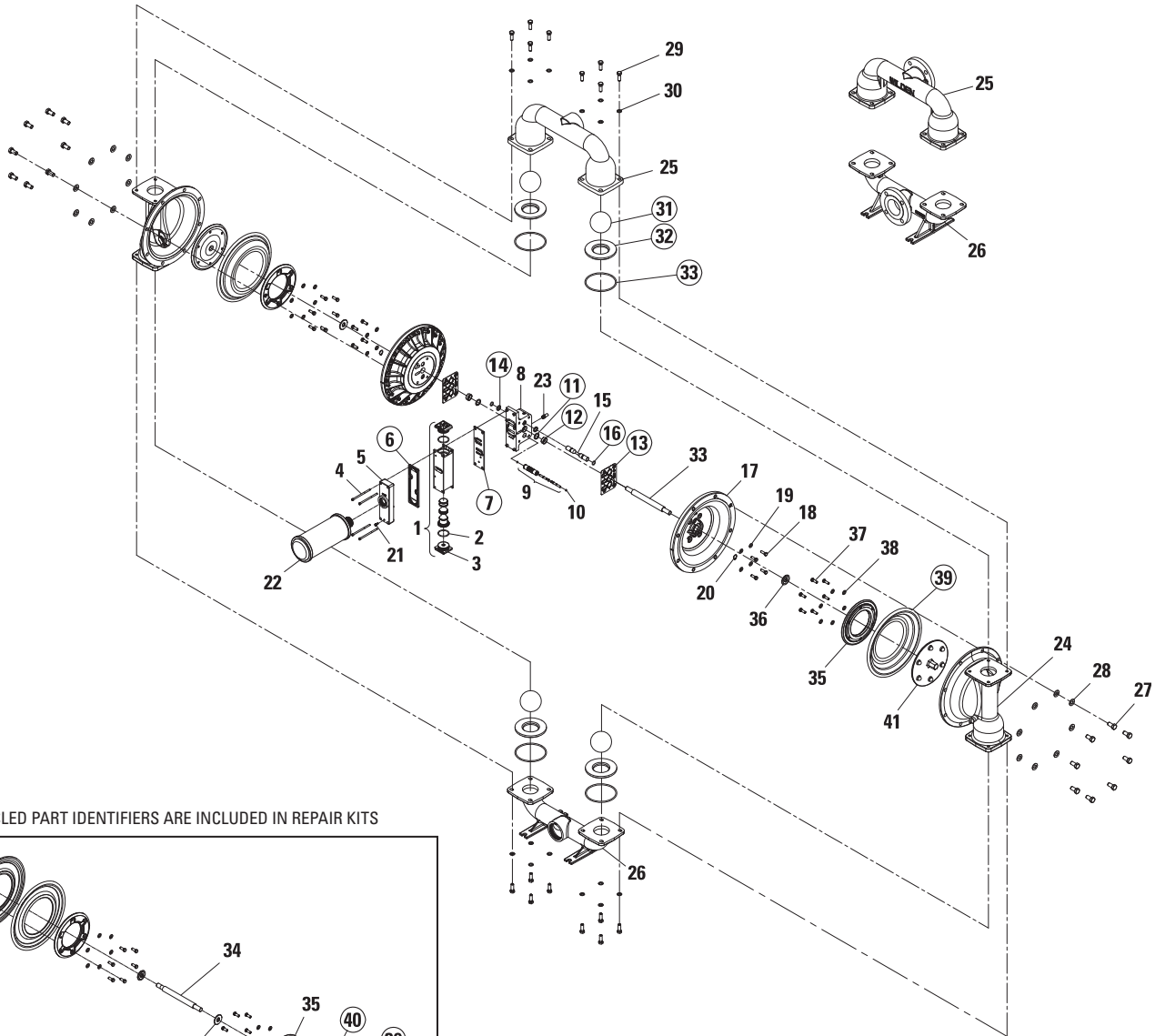

ALL CIRCLED PART IDENTIFIERS ARE INCLUDED IN REPAIR KITS

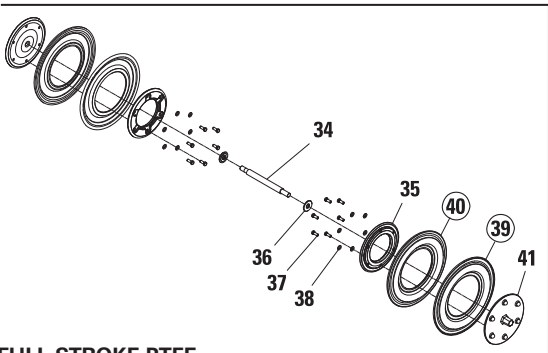

FULL STROKE PTFE

LW0041 REV. B

EXPLODED VIEW & PARTS LISTING

PS1500 STAINLESS STEEL DROP-IN

PARTS LISTING

Item	Description	Qty.	XPS1500/SSAAA/.../0677 P/N
AIR DISTRIBUTION COMPONENTS			
1	Air Valve Assembly, Pro-Flo® SHIFT ¹	1	04-2039-01
2	O-Ring (-225), End Cap (Ø1.859" x Ø.139")	2	04-2390-52-700
3	End Cap	2	04-2340-01
4	Screw, SHC, Air Valve (1/4" -20 x 4-1/2")	4	01-6000-03
5	Muffler Plate, Pro-Flo® SHIFT	1	04-3189-01
6	Gasket, Muffler Plate, Pro-Flo® SHIFT	1	04-3509-52
7	Gasket, Air Valve, Pro-Flo® SHIFT	1	04-2629-52
8	Center Block Assembly, Pro-Flo® SHIFT ²	1	15-3129-01
9	Pilot Sleeve Assembly	1	15-3884-99
10	O-Ring (-009), Pilot Spool Retaining (Ø.208" x Ø.070")	2	04-2650-49-700
11	Seal, Shaft	2	15-3210-55-225
12	Bushing, Shaft	2	15-3306-13
13	Gasket, Center Block Pro-Flo V™	2	04-3529-52
14	Seal, Air Control Spool	2	02-3210-55-225
15	Air Control Spool	1	15-3859-03
16	O-Ring (-114), Air Control Spool Retaining (Ø.612" x Ø.103")	2	04-3879-50
17	Air Chamber, Pro-Flo V™	2	15-3691-01
18	Screw, HHC (3/8" -16 x 1-1/8")	8	15-6130-08
19	Washer, Flat (Ø.406" x Ø.812" x .065")	8	15-6740-08-50
20	Retaining Ring	2	04-3890-03
21	Grounding Screw, (10-32 x .50") Self Tapping	1	04-6345-08
22	Muffler 1-1/2" NPT	1	04-3518-99R
23	Muffler 1/4" NPT	1	04-3240-07
WETTED PATH COMPONENTS			
24	Liquid Chamber, Bolted	2	15-5006-03
25	Manifold, Discharge (NPT)	1	15-5035-03
	Manifold, Discharge (BSPT)	1	15-5036-03
	Manifold, Discharge (ANSI)	1	15-5045-03
	Manifold, Discharge (DIN)	1	15-5046-03
26	Manifold, Inlet (NPT)	1	15-5095-03
	Manifold, Inlet (BSPT)	1	15-5096-03
	Manifold, Inlet (ANSI)	1	15-5125-03
	Manifold, Inlet (DIN)	1	15-5126-03
27	Screw, HHC (5/8" -11 x 2")	16	15-6180-03
28	Spring, Disk (5/8")	16	15-6820-03
29	Screw, HHC (1/2" -13 x 1-1/2")	16	04-6180-03
30	Spring, Disk (1/2")	16	15-6810-03
GASKETS/VALVE BALLS/VALVE SEATS/VALVE O-RINGS			
31	Ball, Valve	4	*
32	Seat, Valve	4	*
33	O-Ring (-358), Valve Seat PTFE Fitted (Ø5.600" x Ø.210")	4	15-1209-55
FULL STROKE RUBBER/TPE/PTFE COMPONENTS			
34	Shaft	1	15-3805-09
35	Piston, Inner	2	15-3700-01
36	Washer, Inner Piston Back-up	2	15-6850-08
37	Screw, HHC (3/8" -16 x 1-1/8")	12	15-6130-08
38	Washer (Ø.406" x Ø.812" x .065")	12	15-6740-08-50
39	Diaphragm, Primary	2	*
40	Diaphragm, Back-Up	2	*
41	Piston, Outer	2	15-4550-03

*See elastomer chart - Section 9

¹Air Valve Assembly includes items 2 and 3

²Metal Center Block Assembly includes item 11,

12, 14, 15 and 16

All boldface items are primary wear parts

LW0051 Rev. E



ELASTOMER OPTIONS

PS1500 Aluminum

MATERIAL	DIAPHRAGM (2)	BACK-UP DIAPHRAGMS FULL STROKE (2)	VALVE BALLS (4)	VALVE SEATS (4)	VALVE SEAT O-RING (4)	T-SECTION GASKET (4)
Polyurethane	15-1022-50	N/A	15-1080-50	15-1126-50	N/A	N/A
Neoprene	15-1010-51	N/A	15-1080-51	15-1126-51	N/A	15-1325-51
Buna-N	15-1010-52	N/A	15-1080-52	15-1126-52	N/A	15-1325-52
Conductive Buna-N	15-1010-86	N/A	N/A	N/A	N/A	N/A
Geolast®	15-1022-15	N/A	N/A	N/A	N/A	N/A
EPDM	15-1010-54	N/A	15-1080-54	15-1126-54	N/A	15-1325-54
Viton®	15-1010-53	N/A	15-1080-53	N/A	N/A	N/A
Full Stroke PTFE	15-1040-55-42	N/A	15-1080-55	N/A	15-1205-55 ¹	15-1325-55
Saniflex™	15-1022-56	15-1065-56	15-1080-56	15-1126-56	N/A	N/A
FDA Wil-Flex™	15-1022-57	15-1065-57	15-1080-57	15-1126-57	N/A	15-1325-57
Wil-Flex™	15-1022-58	N/A	15-1080-58	15-1126-58	N/A	15-1325-58
Stainless Steel	N/A	N/A	N/A	15-1125-03	N/A	N/A

¹Used in conjunction with metallic valve seat

LW0048 REV. E

PS1500 Stainless Steel

MATERIAL	DIAPHRAGM (2)	BACK-UP DIAPHRAGMS FULL STROKE (2)	VALVE BALLS (4)	VALVE SEATS (4)	VALVE SEAT O-RING (4)
Polyurethane	15-1022-50	N/A	15-1080-50	15-1120-50	N/A
Neoprene	15-1010-51	N/A	15-1080-51	15-1120-51	N/A
Buna-N	15-1010-52	N/A	15-1080-52	15-1120-52	N/A
Conductive Buna-N	15-1010-86	N/A	N/A	N/A	N/A
Geolast®	15-1022-15	N/A	N/A	N/A	N/A
EPDM	15-1010-54	N/A	15-1080-54	15-1120-54	N/A
Viton®	15-1010-53	N/A	15-1080-53	15-1120-53	N/A
Full Stroke PTFE	15-1040-55-42	N/A	15-1080-55	N/A	15-1200-55 ¹
Saniflex™	15-1022-56	15-1065-56	15-1080-56	15-1120-56	N/A
FDA Wil-Flex™	15-1022-57	15-1065-57	15-1080-57	15-1120-57	N/A
Wil-Flex™	15-1022-58	N/A	15-1080-58	15-1120-58	N/A
Stainless Steel	N/A	N/A	N/A	15-1121-03	N/A
Alloy C	N/A	N/A	N/A	15-1121-04	N/A

¹Used in conjunction with metallic valve seat

LW0050 REV. F

ELASTOMER OPTIONS

PS1500 Aluminum Drop-In

MATERIAL	DIAPHRAGM (2)	BACK-UP DIAPHRAGMS FULL STROKE (2)	VALVE BALLS (4)	VALVE SEATS (4)	VALVE SEAT O-RING (4)
Polyurethane	15-1022-50	N/A	15-1080-50	15-1126-50	N/A
Neoprene	15-1010-51	N/A	15-1080-51	15-1126-51	N/A
Buna-N	15-1010-52	N/A	15-1080-52	15-1126-52	N/A
Conductive Buna-N	15-1010-86	N/A	N/A	N/A	N/A
Geolast®	15-1022-15	N/A	N/A	N/A	N/A
EPDM	15-1010-54	N/A	15-1080-54	15-1126-54	N/A
Viton®	15-1010-53	N/A	15-1080-53	N/A	N/A
Full Stroke PTFE	15-1040-55-42	N/A	15-1085-55	N/A	15-1205-55 ¹
Saniflex™	15-1022-56	15-1065-56	15-1080-56	15-1126-56	N/A
FDA Wil-Flex™	15-1022-57	15-1065-57	15-1080-57	15-1126-57	N/A
Wil-Flex™	15-1022-58	N/A	15-1080-58	15-1126-58	N/A
Stainless Steel	N/A	N/A	N/A	15-1125-03	N/A

¹Used in conjunction with metallic valve seat

LW0049 REV. E

PS1500 Stainless Steel Drop-In

MATERIAL	DIAPHRAGM (2)	BACK-UP DIAPHRAGMS FULL STROKE (2)	VALVE BALLS (4)	VALVE SEATS (4)	VALVE SEAT O-RING (4)
Polyurethane	15-1022-50	N/A	15-1085-50	15-1128-50	N/A
Neoprene	15-1010-51	N/A	15-1085-51	15-1128-51	N/A
Buna-N	15-1010-52	N/A	15-1085-52	15-1128-52	N/A
Conductive Buna-N	15-1010-86	N/A	N/A	N/A	N/A
Geolast®	15-1022-15	N/A	N/A	N/A	N/A
EPDM	15-1010-54	N/A	15-1085-54	15-1128-54	N/A
Viton®	15-1010-53	N/A	15-1085-53	15-1128-53	N/A
Full Stroke PTFE	15-1040-55-42	N/A	15-1085-55	N/A	15-1209-55 ¹
Saniflex™	15-1022-56	15-1065-56	15-1085-56	15-1128-56	N/A
FDA Wil-Flex™	15-1022-57	15-1065-57	15-1085-57	15-1128-57	N/A
Wil-Flex™	15-1022-58	N/A	15-1085-58	15-1128-58	N/A
Stainless Steel	N/A	N/A	N/A	15-1129-03	N/A

¹Used in conjunction with metallic valve seat

LW0051 REV. D

NOTES

WARRANTY

Each and every product manufactured by Wilden Pump and Engineering, LLC is built to meet the highest standards of quality. Every pump is functionally tested to insure integrity of operation.

Wilden Pump and Engineering, LLC warrants that pumps, accessories and parts manufactured or supplied by it to be free from defects in material and workmanship for a period of five (5) years from date of installation or six (6) years from date of manufacture, whichever comes first. Failure due to normal wear, misapplication, or abuse is, of course, excluded from this warranty.

Since the use of Wilden pumps and parts is beyond our control, we cannot guarantee the suitability of any pump or part for a particular application and Wilden Pump and Engineering, LLC shall not be liable for any consequential damage or expense arising from the use or misuse of its products on any application. Responsibility is limited solely to replacement or repair of defective Wilden pumps and parts.

All decisions as to the cause of failure are the sole determination of Wilden Pump and Engineering, LLC.

Prior approval must be obtained from Wilden for return of any items for warranty consideration and must be accompanied by the appropriate MSDS for the product(s) involved. A Return Goods Tag, obtained from an authorized Wilden distributor, must be included with the items which must be shipped freight prepaid.

The foregoing warranty is exclusive and in lieu of all other warranties expressed or implied (whether written or oral) including all implied warranties of merchantability and fitness for any particular purpose. No distributor or other person is authorized to assume any liability or obligation for Wilden Pump and Engineering, LLC other than expressly provided herein.

PLEASE PRINT OR TYPE AND FAX TO WILDEN

PUMP INFORMATION			
Item # _____		Serial # _____	
Company Where Purchased _____			
YOUR INFORMATION			
Company Name _____			
Industry _____			
Name _____		Title _____	
Street Address _____			
City _____		State _____	Country _____
Postal Code _____		Country _____	
Telephone _____	Fax _____	E-mail _____	Web Address _____
Number of pumps in facility? _____		Number of Wilden pumps? _____	
Types of pumps in facility (check all that apply): <input type="checkbox"/> Diaphragm <input type="checkbox"/> Centrifugal <input type="checkbox"/> Gear <input type="checkbox"/> Submersible <input type="checkbox"/> Lobe			
<input type="checkbox"/> Other _____			
Media being pumped? _____			
How did you hear of Wilden Pump? <input type="checkbox"/> Trade Journal <input type="checkbox"/> Trade Show <input type="checkbox"/> Internet/E-mail <input type="checkbox"/> Distributor			
<input type="checkbox"/> Other _____			

ONCE COMPLETE, FAX TO (909) 783-3440

NOTE: WARRANTY VOID IF PAGE IS NOT FAXED TO WILDEN
WILDEN PUMP & ENGINEERING, LLC

PSG Brands

ABAQUE™
PERISTALTIC PUMPS
mouvex.com

ALMATEC®
AIR-OPERATED
DOUBLE-DIAPHRAGM PUMPS
almatec.de

AUTOMATIK
PELLETIZING SYSTEMS
maag.com

BLACKMER®
VANE PUMPS & COMPRESSORS
blackmer.com

FLUID DYNAMICS™
POLYMER BLENDING SYSTEMS
fluiddynamics1.com

GRISWOLD™
CENTRIFUGAL PUMPS
griswoldpump.com

**MAAG
FILTRATION**
PLASTIC MANUFACTURING &
PROCESSING FILTRATION
maag.com

**MAAG
INDUSTRIAL PUMPS**
GEAR & SCREW PUMPS
maag.com

**MAAG
PUMP SYSTEMS**
EXTRUSION PUMPS & SYSTEMS
maag.com

MOUVEX®
ECCENTRIC DISC PUMPS,
VANE PUMPS &
COMPRESSORS
mouvex.com

NEPTUNE™
DIAPHRAGM (METERING) PUMPS,
POLYMER SYSTEMS & MIXERS
neptune1.com

QUATTROFLOW™
QUATERNARY DIAPHRAGM
PUMP TECHNOLOGY
quattroflow.com

REDSCREW™
SCREW PUMPS
redscrewpump.com

SYSTEM ONE®
CENTRIFUGAL PUMPS
blackmer.com

WILDEN®
AIR-OPERATED
DOUBLE-DIAPHRAGM PUMPS
wildenpump.com



Where Innovation Flows

PSG reserves the right to modify the information and illustrations contained in this document without prior notice. This is a non-contractual document. 01-2013

Authorized PSG Representative:

WILDEN®
Part of Pump Solutions Group
A DOVER COMPANY

22069 Van Buren St.
Grand Terrace, CA 92313-5607
T: +1 (909) 422-1731
F: +1 (909) 783-3440

Copyright 2013, Pump Solutions Group (PSG), A Dover Company