

P2

EOM

Engineering
Operation &
Maintenance

Original™ Series **PLASTIC** Pumps



Simplify your process

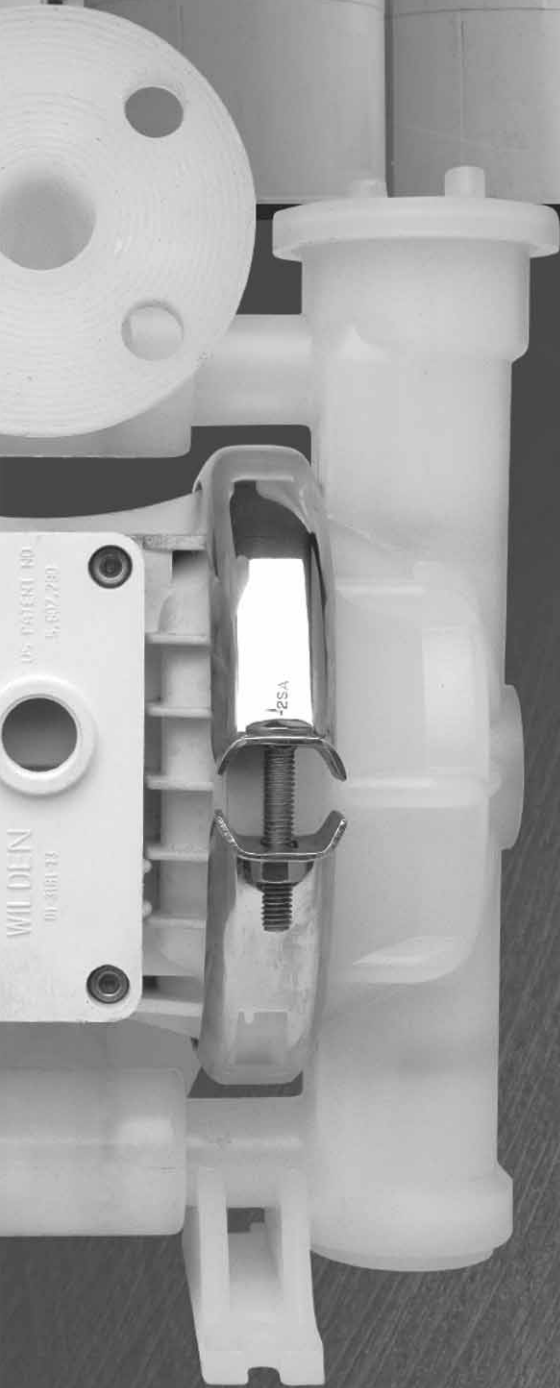

PROFLO[®]
PROGRESSIVE PUMP TECHNOLOGY

WILDEN[®]

A **DOVER** COMPANY



WIL-10150-E-06
REPLACES WIL-10150-E-05

TABLE OF CONTENTS

SECTION 1 CAUTIONS—READ FIRST! 1

SECTION 2 WILDEN PUMP DESIGNATION SYSTEM 2

SECTION 3 HOW IT WORKS—PUMP & AIR DISTRIBUTION SYSTEM 3

SECTION 4 DIMENSIONAL DRAWINGS 4

SECTION 5 PERFORMANCE

 A. P2 Performance Curves

 Rubber-Fitted 5

 TPE-Fitted 5

 Reduced Stroke PTFE-Fitted 6

 Full Stroke PTFE-Fitted 6

 B. Suction Lift Curves 7

SECTION 6 SUGGESTED INSTALLATION, OPERATION & TROUBLESHOOTING 8

SECTION 7 ASSEMBLY / DISASSEMBLY 11

 Reassembly Hints & Tips 16

 Gasket Kit Installation 17

SECTION 8 EXPLODED VIEW & PARTS LISTING

 P2 Plastic Full Stroke Diaphragm-Fitted 18

 P2 Plastic Reduced Stroke Diaphragm-Fitted 20

SECTION 9 ELASTOMER OPTIONS 22



CAUTIONS—READ FIRST!



TEMPERATURE LIMITS:

Polypropylene	0°C to 79°C	32°F to 175°F
PVDF	-12°C to 107°C	10°F to 225°F
Buna-N	-12.2°C to 82.2°C	10°F to 180°F
Neoprene	-17.8°C to 93.3°C	0°F to 200°F
EDPM	-51.1°C to 137.8°C	-60°F to 280°F
Polyurethane	12.2°C to 65.6°C	10°F to 150°F
Saniflex™	-28.9°C to 104.4°C	-20°F to 220°F
PTFE	4.4°C to 104.4°C	40°F to 220°F
Tetra-Flex™ PTFE Neoprene Backed	4.4° to 107.2°C	40°F to 225°F
Tetra-Flex™ PTFE EPDM Backed	-10° to 137°C	14°F to 280°F
Tetra-Flex™	4.4° to 107.2°C	40°F to 225°F
Viton®	-40°C to 176.7°C	-40°F to 350°F
Wil-Flex™	-40°C to 107.2°C	-40°F to 225°F



CAUTION: When choosing pump materials, be sure to check the temperature limits for all wetted components. Example: Viton® has a maximum limit of 176.7°C (350°F) but polypropylene has a maximum limit of only 79°C (175°F).



CAUTION: Maximum temperature limits are based upon mechanical stress only. Certain chemicals will significantly reduce maximum safe operating temperatures. Consult engineering guide for chemical compatibility and temperature limits.



CAUTION: Always wear safety glasses when operating pump. If diaphragm rupture occurs, material being pumped may be forced out air exhaust.



WARNING: Prevention of static sparking — If static sparking occurs, fire or explosion could result. Pump, valves, and containers must be properly grounded when handling flammable fluids and whenever discharge of static electricity is a hazard.



CAUTION: Do not exceed 8.6 bar (125 psig) air supply pressure.



CAUTION: P2 pumps are made of virgin plastic and are not UV stabilized. Direct sunlight for prolonged periods can cause deterioration of plastics.



CAUTION: Before any maintenance or repair is attempted, the compressed air line to the pump should be disconnected and all air pressure allowed to bleed from pump. Disconnect all intake, discharge and air lines. Drain the pump by turning it upside down and allowing any fluid to flow into a suitable container.



CAUTION: Blow out air line for 10 to 20 seconds before attaching to pump to make sure all pipe line debris is clear. Use an in-line air filter. **A 5µ (micron) air filter is recommended.**



NOTE: Tighten clamp bands and retainers prior to installation. Fittings may loosen during transportation.



NOTE: When installing PTFE diaphragms, it is important to tighten outer pistons simultaneously (turning in opposite directions) to ensure tight fit.



NOTE: Before starting disassembly, mark a line from each liquid chamber to its corresponding air chamber. This line will assist in proper alignment during reassembly.



CAUTION: Verify the chemical compatibility of the process and cleaning fluid to the pump's component materials in the Chemical Resistance Guide (see RBG E4).



CAUTION: When removing the end cap using compressed air, the air valve end cap may come out with considerable force. Hand protection such as a padded glove or rag should be used to capture the end cap.



CAUTION: P2 PTFE-fitted pumps come standard from the factory with expanded PTFE gaskets. (See Gasket Kit Installation in Section



CAUTION: Do not over-tighten the air inlet reducer bushing. Too much torque on the reducer bushing may damage the air valve muffler plate. Do not exceed 0.9 N·m (8in-lbs).



NOTE: When reinstalling the outer pistons, apply two (2) drops of Loctite® 246 to the shaft internal threads before the diaphragm assembly.

WILDEN PUMP DESIGNATION SYSTEM

**P2 ORIGINAL™
PLASTIC**

**25 mm (1") Pump
Maximum Flow Rate:
140 lpm (37 gpm)**

LEGEND

P2 / XXXXX / XXX / XX / XXX / XXXX

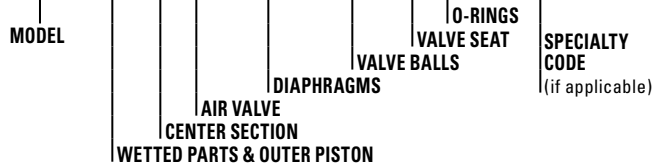

MATERIAL CODES

WETTED PARTS & OUTER PISTON

- KK = PVDF / PVDF
- PP = POLYPROPYLENE / POLYPROPYLENE
- PK = POLYPROPYLENE / PVDF

CENTER SECTION

- LL = ACETAL
- PP = POLYPROPYLENE

AIR VALVE

- L = ACETAL
- P = POLYPROPYLENE

DIAPHRAGMS

- BNS = BUNA-N (Red Dot)
- EPS = EPDM (Blue Dot)
- FSS = SANIFLEX™ [Hytrel® (Cream)]
- NES = NEOPRENE (Green Dot)
- PUS = POLYURETHANE (Clear)
- TEU = PTFE W/EPDM BACK-UP (White)
- TNU = PTFE W/NEOPRENE BACK-UP (White)
- TSU = PTFE W/SANIFLEX™ BACK-UP (White)
- VTS = VITON® (White Dot)
- WFS = WIL-FLEX™ [Santoprene® (Orange Dot)]
- TSS = FULL STROKE PTFE W/SANIFLEX™ BACK-UP
- TWS = FULL STROKE PTFE W/WIL-FLEX™ BACK-UP

VALVE BALL

- BN = BUNA-N (Red Dot)
- EP = EPDM (Blue Dot)
- FS = SANIFLEX™ [Hytrel® (Cream)]
- NE = NEOPRENE (Green Dot)
- PU = POLYURETHANE (Brown)
- TF = PTFE (White)
- VT = VITON® (White Dot)
- WF = WIL-FLEX™ [Santoprene® (Orange Dot)]

VALVE SEAT

- K = PVDF
- P = POLYPROPYLENE

VALVE SEAT O-RING

- BN = BUNA-N
- PU = POLYURETHANE (Brown)
- TV = PTFE ENCAP. VITON®
- WF = WIL-FLEX™ [Santoprene®]

SPECIALTY CODES

- | | | |
|--|---|---|
| 0100 Wil-Gard II™ 110V | 0420 P2 plastic, Wil-Gard II™ 110V | 0563 Split manifold, discharge ONLY |
| 0102 Wil-Gard II™ sensor wires ONLY | 0423 P2 plastic, PFA coated hardware, Wil-Gard II™ 110V | 0564 Split manifold, inlet ONLY |
| 0103 Wil-Gard II™ 220V | 0424 P2 plastic, Wil-Gard II™ 220V, DIN flange | 0603 PFA coated hardware, Wil-Gard II™ 110V |
| 0206 PFA coated hardware, Wil-Gard II™ sensor wires ONLY | 0426 P2 plastic, PFA coated hardware, Wil-Gard II™ 220V, DIN flange | 0608 PFA coated hardware, Wil-Gard II™ 220V |
| 0400 P2 plastic | 0428 P2 plastic, Wil-Gard II™ 220V | 0660 Split manifold, Wil-Gard II™ 110V |
| 0402 P2 plastic, PFA coated hardware | 0430 P2 plastic, SS outer pistons | 0661 Split manifold, PFA coated hardware, Wil-Gard II™ 110V |
| 0404 P2 plastic, DIN flange | 0502 PFA coated hardware | |
| 0406 P2 plastic, PFA coated hardware, DIN flange | 0560 Split manifold | |
| 0415 P2 plastic, Wil-Gard II™ sensor wires ONLY | 0561 Split manifold, PFA coated hardware | |
| 0416 P2, PFA coated hardware, Wil-Gard II™ sensor wires ONLY | | |

NOTE: MOST ELASTOMERIC MATERIALS USE COLORED DOTS FOR IDENTIFICATION.

Viton® is registered trademarks of DuPont Dow Elastomers.

HOW IT WORKS

The Wilden diaphragm pump is an air-operated, positive displacement, self-priming pump. These drawings show the flow pattern through the pump upon its initial stroke. It is assumed the pump has no fluid in it prior to its stroke.

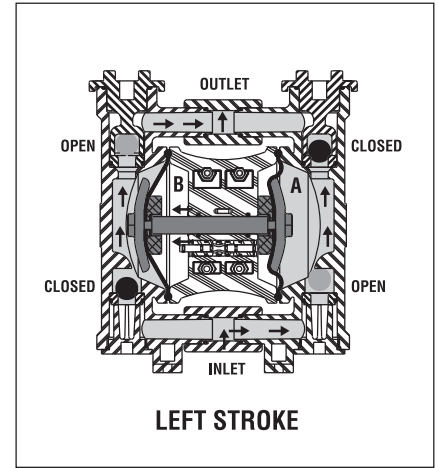
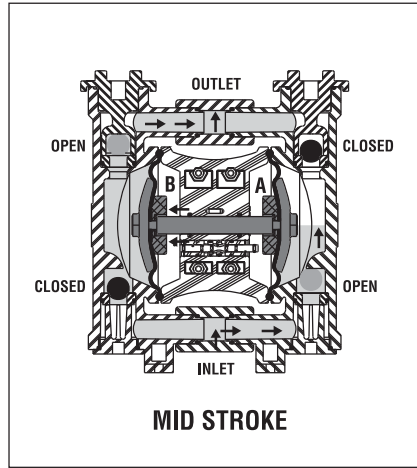
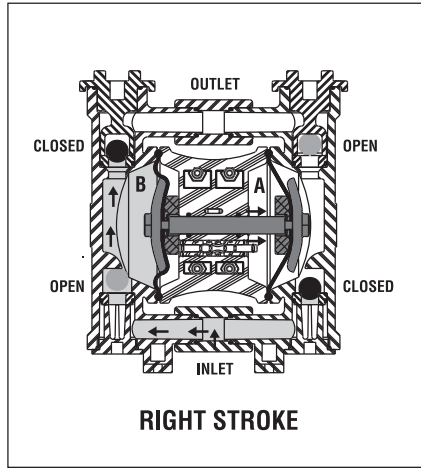

FIGURE 1 The air valve directs pressurized air to the back side of diaphragm A. The compressed air is applied directly to the liquid column separated by elastomeric diaphragms. The diaphragm acts as a separation membrane between the compressed air and liquid, balancing the load and removing mechanical stress from the diaphragm. The compressed air moves the diaphragm away from the center block of the pump. The opposite diaphragm is pulled in by the shaft connected to the pressurized diaphragm. Diaphragm B is on its suction stroke; air behind the diaphragm has been forced out to the atmosphere through the exhaust port of the pump. The movement of diaphragm B toward the center block of the pump creates a vacuum within chamber B. Atmospheric pressure forces fluid into the inlet manifold forcing the inlet valve ball off its seat. Liquid is free to move past the inlet valve ball and fill the liquid chamber (see shaded area).

FIGURE 2 When the pressurized diaphragm, diaphragm A, reaches the limit of its discharge stroke, the air valve redirects pressurized air to the back side of diaphragm B. The pressurized air forces diaphragm B away from the center block while pulling diaphragm A to the center block. Diaphragm B is now on its discharge stroke. Diaphragm B forces the inlet valve ball onto its seat due to the hydraulic forces developed in the liquid chamber and manifold of the pump. These same hydraulic forces lift the discharge valve ball off its seat, while the opposite discharge valve ball is forced onto its seat, forcing fluid to flow through the pump discharge. The movement of diaphragm A toward the center block of the pump creates a vacuum within liquid chamber A. Atmospheric pressure forces fluid into the inlet manifold of the pump. The inlet valve ball is forced off its seat allowing the fluid being pumped to fill the liquid chamber.

FIGURE 3 At completion of the stroke, the air valve again redirects air to the back side of diaphragm A, which starts diaphragm B on its exhaust stroke. As the pump reaches its original starting point, each diaphragm has gone through one exhaust and one discharge stroke. This constitutes one complete pumping cycle. The pump may take several cycles to completely prime depending on the conditions of the application.

HOW IT WORKS—AIR DISTRIBUTION SYSTEM

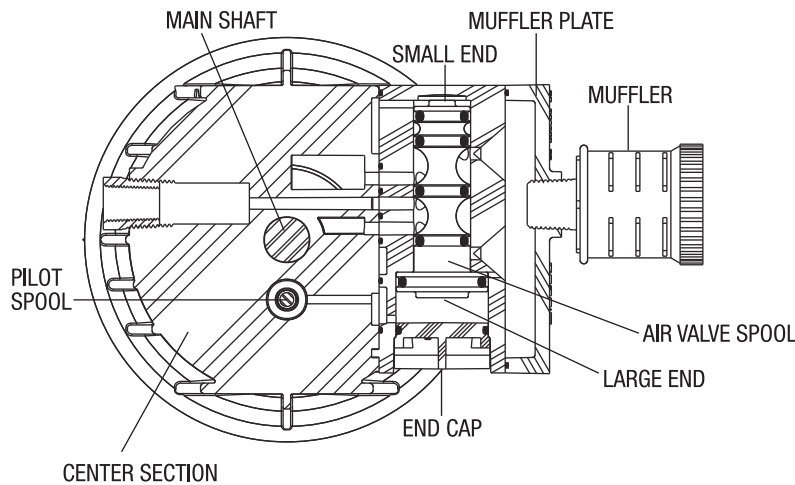
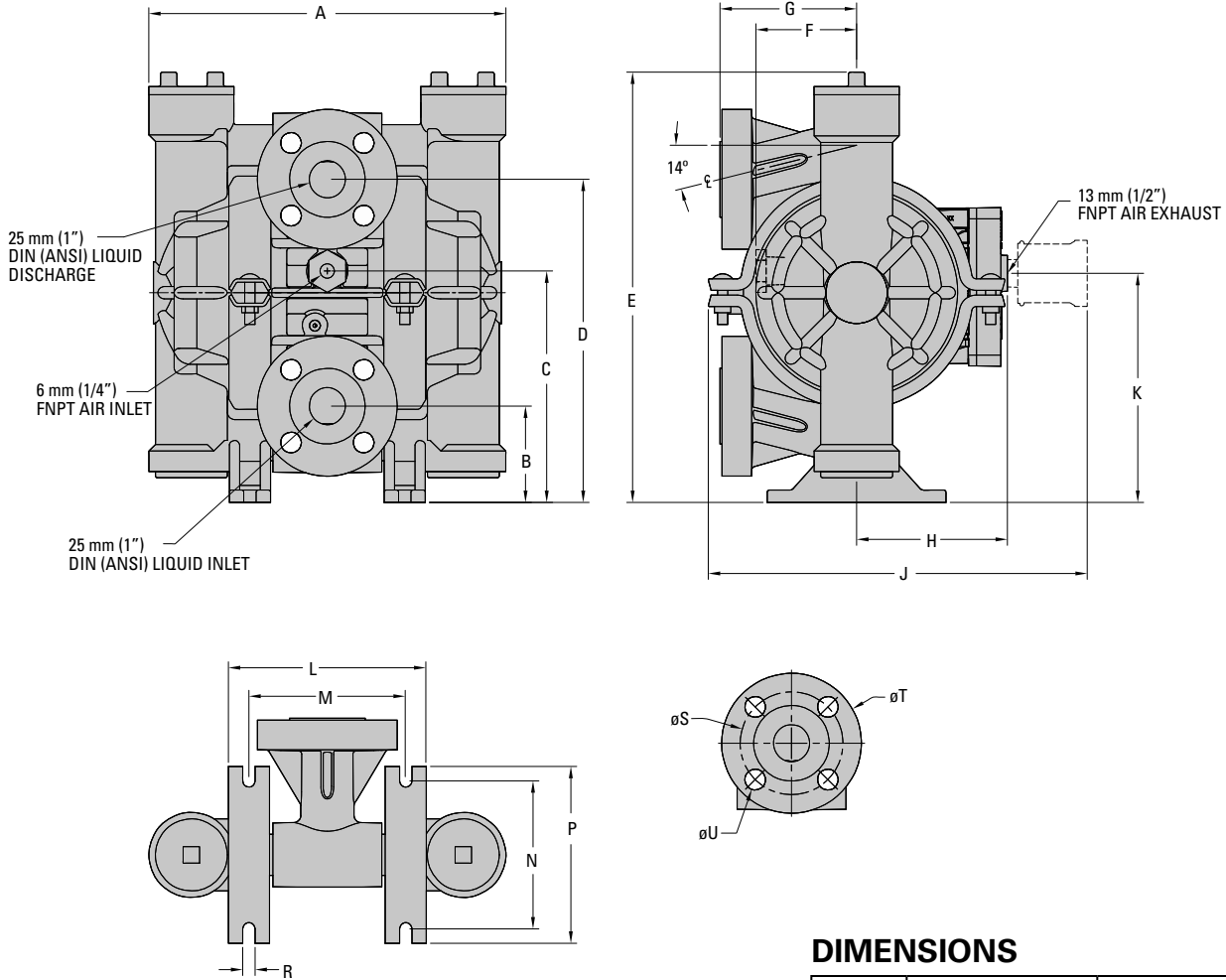

Figure A The Pro-Flo® patented air distribution system incorporates three moving parts: the air valve spool, the pilot spool, and the main shaft/diaphragm assembly. The heart of the system is the air valve spool and air valve. As shown in Figure A, this valve design incorporates an unbalanced spool. The smaller end of the spool is pressurized continuously, while the large end is alternately pressurized then exhausted to move the spool. The spool directs pressurized air to one air chamber while exhausting the other. The air causes the main shaft/diaphragm assembly to shift to one side — discharging liquid on that side and pulling liquid in on the other side. When the shaft reaches the end of its stroke, the inner piston actuates the pilot spool, which pressurizes and exhausts the large end of the air valve spool. The repositioning of the air valve spool routes the air to the other air chamber.

DIMENSIONAL DRAWINGS



DIMENSIONS

ITEM	METRIC (mm)	STANDARD (Inch)
A	277	10.9
B	76	3.0
C	180	7.1
D	249	9.8
E	333	13.1
F	81	3.2
G	107	4.2
H	124	4.9
J	292	11.5
K	180	7.1
L	152	6.0
M	122	4.8
N	114	4.5
P	137	5.4
R	10	0.4
DIN		
S	84 DIA	3.3 DIA
T	114 DIA	4.5 DIA
U	15 DIA	.6 DIA
ANSI		
S	79 DIA	3.1 DIA
T	109 DIA	4.3 DIA
U	15 DIA	.6 DIA

SUCTION LIFT CURVE

**P2 PLASTIC
SUCTION LIFT
CAPABILITY**

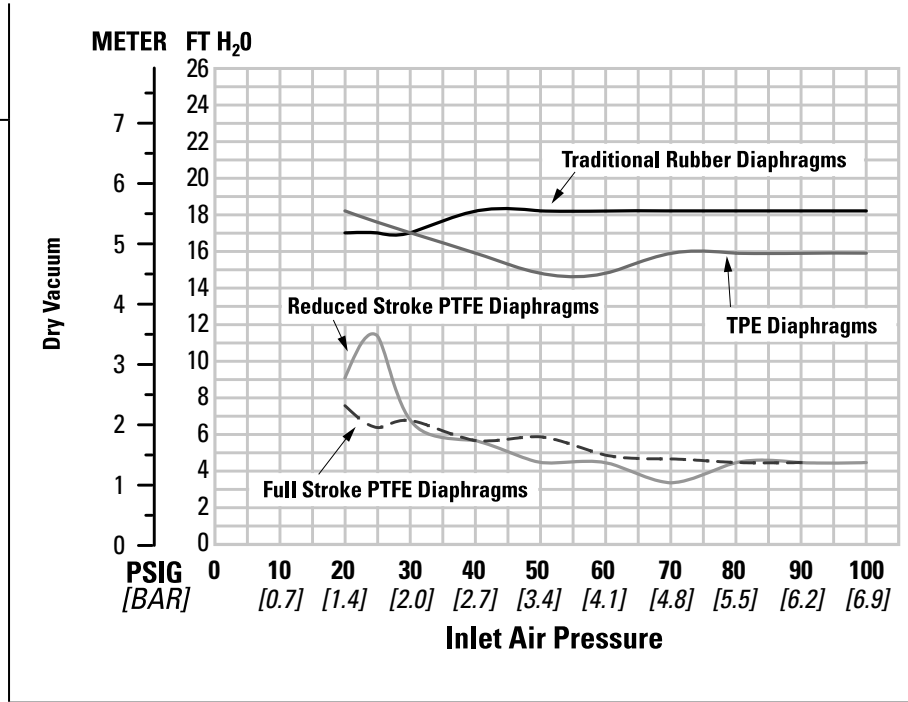

Suction lift curves are calibrated for pumps operating at 305 m (1,000') above sea level. This chart is meant to be a guide only. There are many variables which can affect your pump's operating characteristics. The number of intake and

discharge elbows, viscosity of pumping fluid, elevation (atmospheric pressure) and pipe friction loss all affect the amount of suction lift your pump will attain.

SUGGESTED INSTALLATION

The Pro-Flo® model P2 has a 25 mm (1") inlet and 25 mm (1") outlet and is designed for flows to 140 lpm (37 gpm). The **P2 Plastic** pump is manufactured with wetted parts of pure, unpigmented PVDF or polypropylene. The **P2 Plastic** is constructed with a polypropylene or acetal center section. A variety of diaphragms and o-rings are available to satisfy temperature, chemical compatibility, abrasion and flex concerns.

The suction pipe size should be at least 25 mm (1") diameter or larger if highly viscous material is being pumped. The suction hose must be non-collapsible, reinforced type as the P2 is capable of pulling a high vacuum. Discharge piping should be at least 25 mm (1"); larger diameter can be used to reduce friction losses. It is critical that all fittings and connections are airtight or a reduction or loss of pump suction capability will result.

INSTALLATION: Months of careful planning, study, and selection efforts can result in unsatisfactory pump performance if installation details are left to chance.

Premature failure and long term dissatisfaction can be avoided if reasonable care is exercised throughout the installation process.

LOCATION: Noise, safety, and other logistical factors usually dictate where equipment be situated on the production floor. Multiple installations with conflicting requirements can result in congestion of utility areas, leaving few choices for additional pumps.

Within the framework of these and other existing conditions, every pump should be located in such a way that five key factors are balanced against each other to maximum advantage.

ACCESS: First of all, the location should be accessible. If it's easy to reach the pump, maintenance personnel will have an easier time carrying out routine inspections and adjustments. Should major repairs become necessary, ease of access can play a key role in speeding the repair process and reducing total downtime.

AIR SUPPLY: Every pump location should have an air line large enough to supply the volume of air necessary to achieve the desired pumping rate (see Section 5). Use air pressure up to a maximum of 8.6 bar (125 psig) depending on pumping requirements.

For best results, the pumps should use a 5µ micron air filter, needle valve and regulator. The use of an air filter before the pump will insure that the majority of any pipeline contaminants will be eliminated.

SOLENOID OPERATION: When operation is controlled by a solenoid valve in the air line, three-way valves should be used, thus allowing trapped air to bleed off and improving pump performance. Pumping volume can be set by counting the number of strokes per minute and multiplying by displacement per stroke.

Sound levels are reduced below OSHA specifications using the standard Wilden muffler element. Other mufflers can be used but usually reduce pump performance.

ELEVATION: Selecting a site that is well within the pump's dynamic lift capability will assure that loss-of-prime troubles will be eliminated. In addition, pump efficiency can be adversely affected if proper attention is not given to site location.

PIPING: Final determination of the pump site should not be made until the piping problems of each possible location have been evaluated. The impact of current and future installations should be considered ahead of time to make sure that inadvertent restrictions are not created for any remaining sites.

The best choice possible will be a site involving the shortest and straightest hook-up of suction and discharge piping. Unnecessary elbows, bends, and fittings should be avoided. Pipe sizes should be selected so as to keep friction losses within practical limits. All piping should be supported independently of the pump. In addition, the piping should be aligned so as to avoid placing stresses on the pump fittings.

Flexible hose can be installed to aid in absorbing the forces created by the natural reciprocating action of the pump. If the pump is to be bolted down to a solid location, a mounting pad placed between the pump and the foundation will assist in minimizing pump vibration. Flexible connections between the pump and rigid piping will also assist in minimizing pump vibration. If quick-closing valves are installed at any point in the discharge system, or if pulsation within a system becomes a problem, a surge suppressor should be installed to protect the pump, piping and gauges from surges and water hammer.

The P2 can be installed in submersible applications only when both the wetted and non-wetted portions are compatible with the material being pumped. If the pump is to be used in a submersible application, a hose should be attached to the pump's air and pilot spool exhaust ports and piped above the liquid level. The exhaust area for the pilot spool is designed to be tapped for a 1/8" NPT fitting.

When pumps are installed in applications involving flooded suction or suction head pressures, a gate valve should be installed in the suction line to permit closing of the line for pump service.

If the pump is to be used in a self-priming application, be sure that all connections are airtight and that the suction lift is within the model's ability. Note: Materials of construction and elastomer material have an effect on suction lift parameters. Please consult Wilden distributors for specifics.

Pumps in service with a positive suction head are most efficient when inlet pressure is limited to 0.5–0.7 bar (7–10 psig). Premature diaphragm failure may occur if positive suction is 10 psig and higher.

THE MODEL P2 WILL PASS 3.2 mm (1/8") SOLIDS. WHENEVER THE POSSIBILITY EXISTS THAT LARGER SOLID OBJECTS MAY BE SUCKED INTO THE PUMP, A STRAINER SHOULD BE USED ON THE SUCTION LINE.

CAUTION: DO NOT EXCEED 8.6 BAR (125 PSIG) AIR SUPPLY PRESSURE.

SUGGESTED INSTALLATION

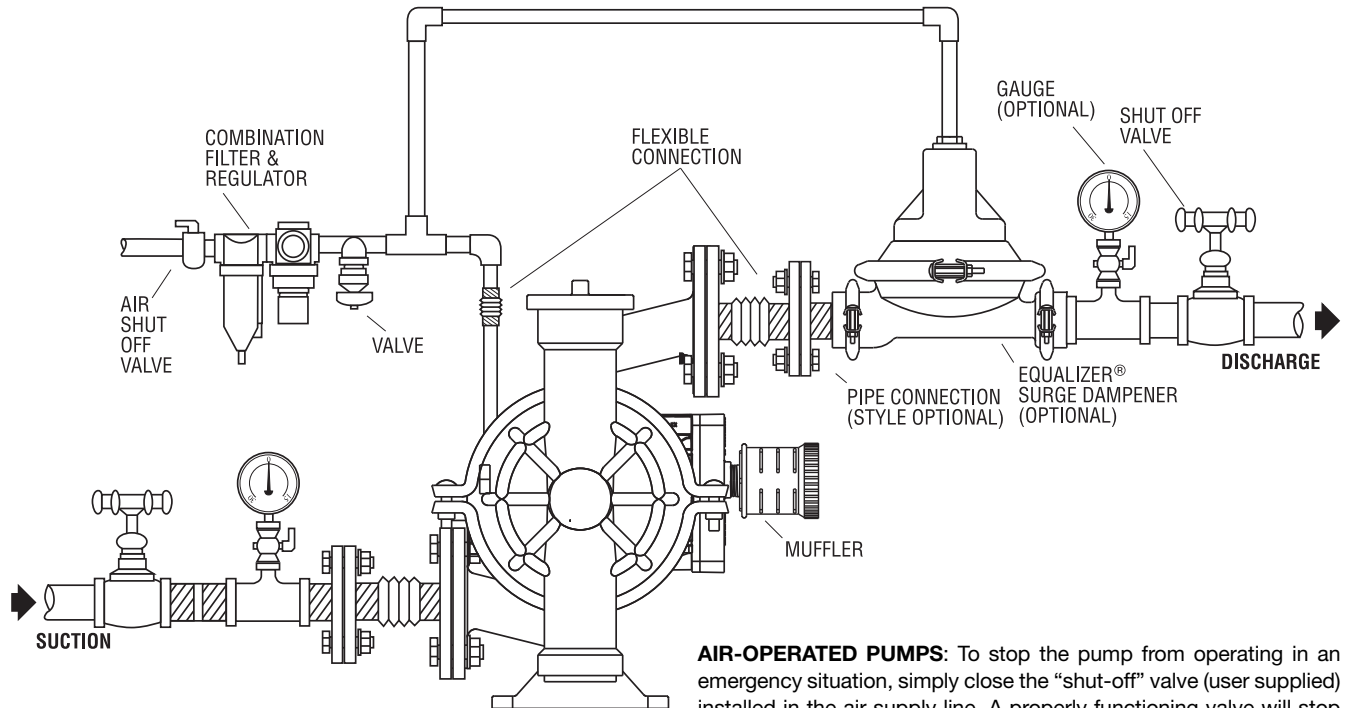

AIR-OPERATED PUMPS: To stop the pump from operating in an emergency situation, simply close the “shut-off” valve (user supplied) installed in the air supply line. A properly functioning valve will stop the air supply to the pump, therefore stopping output. This shut-off valve should be located far enough away from the pumping equipment such that it can be reached safely in an emergency situation.

NOTE: In the event of a power failure, the shutoff valve should be closed, if the restarting of the pump is not desirable once power is regained.

SUGGESTED OPERATION & MAINTENANCE

OPERATION: Pump discharge rate can be controlled by limiting the volume and/or pressure of the air supply to the pump (preferred method). An air regulator is used to regulate air pressure. A needle valve is used to regulate volume. Pump discharge rate can also be controlled by throttling the pump discharge by partially closing a valve in the discharge line of the pump. This action increases friction loss which reduces flow rate. This is useful when the need exists to control the pump from a remote location. When the pump discharge pressure equals or exceeds the air supply pressure, the pump will stop; no bypass or pressure relief valve is needed, and pump damage will not occur. The pump has reached a “deadhead” situation and can be restarted by reducing the fluid discharge pressure or increasing the air inlet pressure. The Wilden P2 pump runs solely on compressed air and does not generate heat, therefore your process fluid temperature will not be affected.

RECORDS: When service is required, a record should be made of all necessary repairs and replacements. Over a period of time, such records can become a valuable tool for predicting and preventing future maintenance problems and unscheduled downtime. In addition, accurate records make it possible to identify pumps that are poorly suited to their applications.

MAINTENANCE AND INSPECTIONS: Since each application is unique, maintenance schedules may be different for every pump. Frequency of use, line pressure, viscosity and abrasiveness of process fluid all affect the parts life of a Wilden pump. Periodic inspections have been found to offer the best means for preventing unscheduled pump downtime. Personnel familiar with the pump’s construction and service should be informed of any abnormalities that are detected during operation.

Pump will not run or runs slowly.

1. Ensure that the air inlet pressure is at least 0.4 bar (5 psig) above startup pressure and that the differential pressure (the difference between air inlet and liquid discharge pressures) is not less than 0.7 bar (10 psig).
2. Check air inlet filter for debris (see recommended installation).
3. Check for extreme air leakage (blow by) which would indicate worn seals/bores in the air valve, pilot spool, main shaft.
4. Disassemble pump and check for obstructions in the air passageways or objects which would obstruct the movement of internal parts.
5. Check for sticking ball check valves. If material being pumped is not compatible with pump elastomers, swelling may occur. Replace ball check valves and seals with proper elastomers. Also, as the check valve balls wear out, they become smaller and can become stuck in the seats. In this case, replace balls and seats.
6. Check for broken inner piston which will cause the air valve spool to be unable to shift.
7. Remove plug from pilot spool exhaust.

Pump runs but little or no product flows.

1. Check for pump cavitation; slow pump speed down to allow thick material to flow into liquid chambers.
2. Verify that vacuum required to lift liquid is not greater than the vapor pressure of the material being pumped (cavitation).

3. Check for sticking ball check valves. If material being pumped is not compatible with pump elastomers, swelling may occur. Replace ball check valves and seals with proper elastomers. Also, as the check valve balls wear out, they become smaller and can become stuck in the seats. In this case, replace balls and seats.

Pump air valve freezes.

1. Check for excessive moisture in compressed air. Either install a dryer or hot air generator for compressed air. Alternatively, a coalescing filter may be used to remove the water from the compressed air in some applications.

Air bubbles in pump discharge.

1. Check for ruptured diaphragm.
2. Check tightness of outer pistons (refer to Section 8C).
3. Check tightness of clamp bands and integrity of o-rings and seals, especially at intake manifold.
4. Ensure pipe connections are airtight.

Product comes out air exhaust.

1. Check for diaphragm rupture.
2. Check tightness of outer pistons to shaft.

CAUTION: Before any maintenance or repair is attempted, the compressed air line to the pump should be disconnected and all air pressure allowed to bleed from the pump. Disconnect all intake, discharge, and air lines. Drain the pump by turning it upside down and allowing any fluid to flow into a suitable container. Be aware of any hazardous effects of contact with your process fluid.

The Wilden model P2 has a 25 mm (1") inlet and 25 mm (1") outlet and is designed for flows up to 140 lpm (37 gpm). The wetted path comes in both PVDF and polypropylene. The single-piece center section, consisting of center block and air chambers, is molded of polypropylene or acetal. The air valve body is manufactured of acetal or polypropylene. All o-rings used in the pump are of a special material and shore hardness that should only be replaced with factory-supplied parts.

TOOLS REQUIRED:

1/2" Box Wrench
 1/2" Socket
 1/2" Socket Drive
 2 – 1" Sockets or Adjustable Wrench
 Adjustable Wrench
 Vise equipped with soft jaws (such as plywood, plastic or other suitable material)

NOTE: The model used for these instructions incorporates rubber diaphragms, balls, and seats. Models with PTFE diaphragms, balls and seats are the same except where noted.

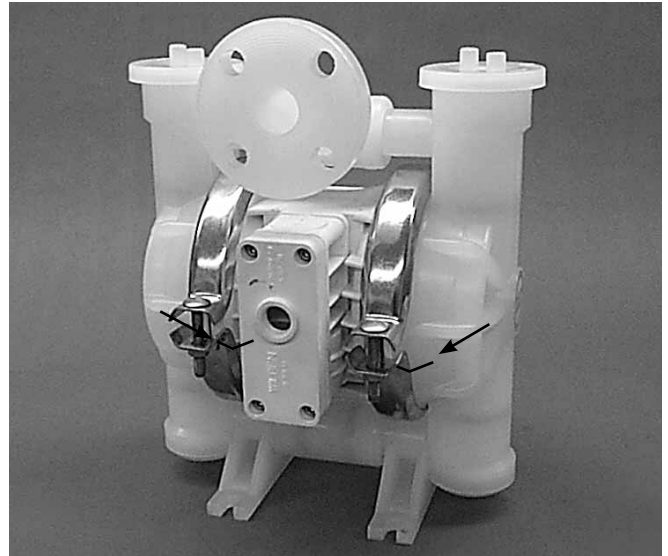

DISASSEMBLY:

Figure 1

Step 1.

Before starting disassembly, mark a line from each liquid chamber to its corresponding air chamber. This line will assist in proper alignment during reassembly.



Step 2.

Figure 2

Using a screwdriver or other long, slim object, loosen the top liquid retainers from the liquid chambers.

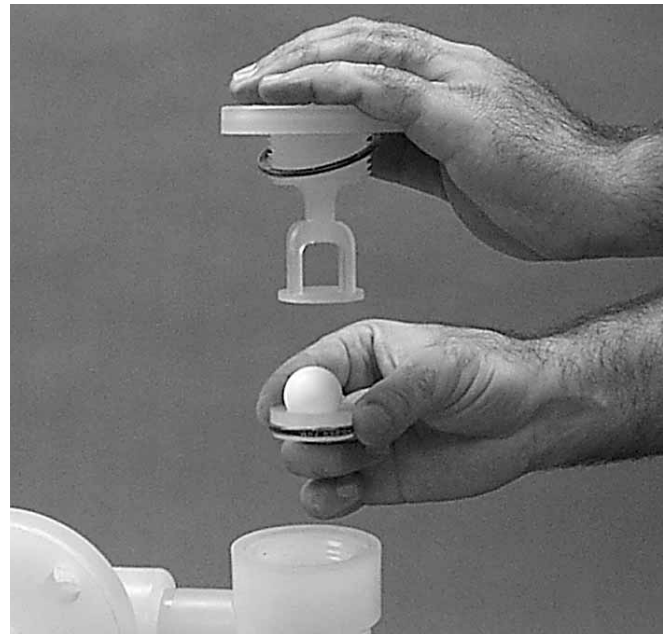

Step 3.

Figure 3

Remove the top liquid retainer to expose the valve balls, valve seats and valve seat o-rings.

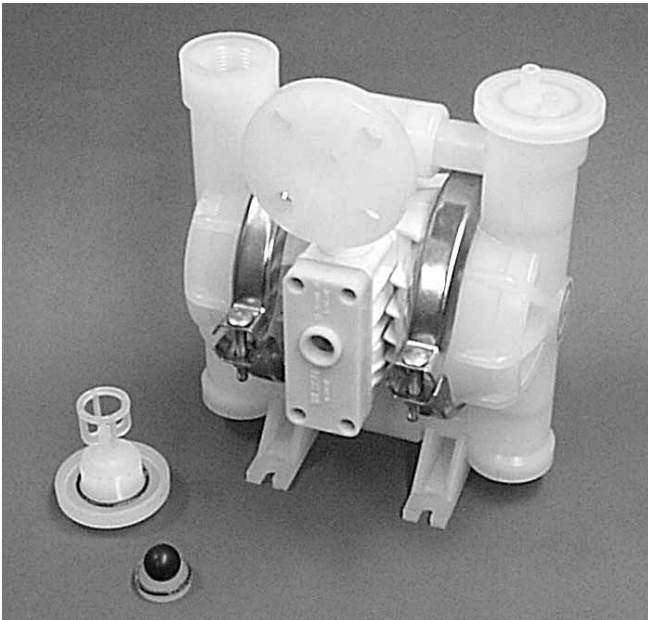

Step 4. *Figure 4*

Remove the top liquid retainer and retainer o-rings, discharge valve balls, seats and valve seat o-rings from the liquid chamber and inspect for nicks, gouges, chemical attack or abrasive wear. Replace worn parts with genuine Wilden parts for reliable performance.



Step 5. *Figure 5*

Using a 1/2" socket driver, loosen the bottom retainers.



Step 6. *Figure 6*

Remove the bottom liquid retainer and retainer o-rings, discharge valve balls, seats and valve seat o-rings from the liquid chamber and inspect for nicks, gouges, chemical attack or abrasive wear. Replace worn parts with genuine Wilden parts for reliable performance.

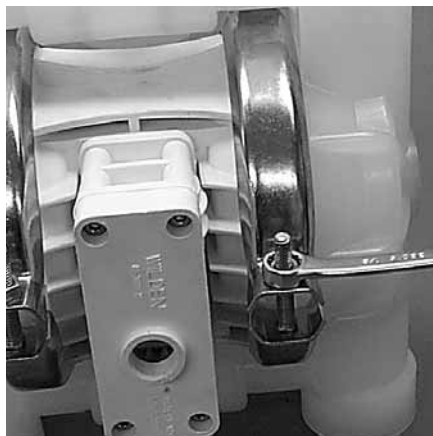

Step 7. *Figure 7*

With a 1/2" box wrench, loosen the large clamp bands that secure the liquid chambers to the center section.



Step 8. *Figure 8*

Rotate the clamp bands so that they can be removed.



Step 9. *Figure 9*
After clamp bands are removed, pull liquid chambers apart.

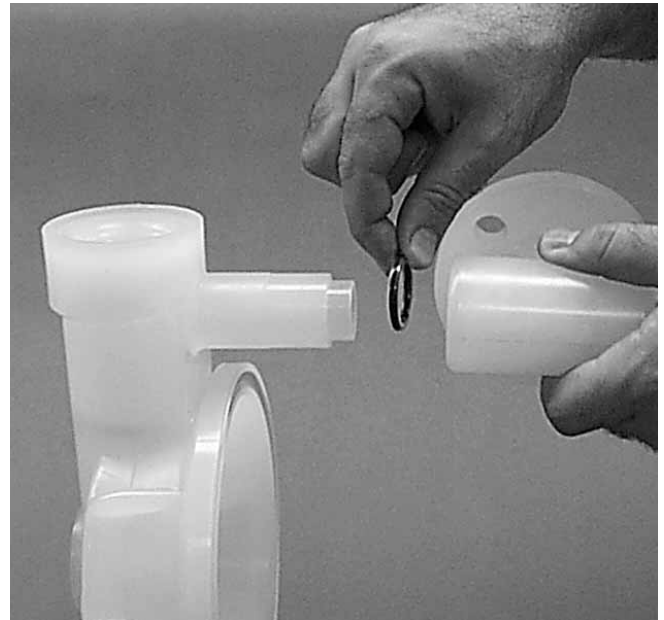

Step 10. *Figure 10*
Remove tee section from liquid chamber and inspect o-rings for signs of wear. Replace worn parts with genuine Wilden parts for reliable performance.



Step 11. *Figure 11*
Using two 1" sockets, remove diaphragm assembly from center section assembly.

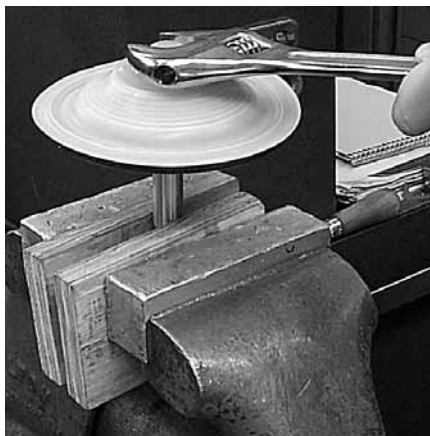

Step 12. *Figure 12*
To remove the remaining diaphragm assembly from the shaft, secure shaft with soft jaws (a vise fitted with plywood or other suitable material) to ensure shaft is not nicked, scratched, or gouged. Using an adjustable wrench, remove diaphragm assembly from shaft. Inspect all parts for wear and replace with genuine Wilden parts if necessary.



Step 13. *Figure 13*
Inspect diaphragms, outer and inner pistons and disc spring (not shown) for signs of wear. Replace with genuine Wilden parts if necessary.

AIR VALVE DISASSEMBLY:

CAUTION: Before any maintenance or repair is attempted, the compressed air line to the pump should be disconnected and all air pressure allowed to bleed from the pump. Disconnect all intake, discharge, and air lines. Drain the pump by turning it upside down and allowing any fluid to flow into a suitable container. Be aware of hazardous effects of contact with your process fluid.

The Wilden Plastic P2 utilizes a revolutionary Pro-Flo® air distribution system. A 6 mm (1/4") air inlet connects the air supply to the center section. Proprietary composite seals reduce the coefficient of friction and allow the P2 to run lube-free. Constructed of acetal or polypropylene, the Pro-Flo® air distribution system is designed to perform in on/off, non-freezing, non-stalling, tough duty applications.

TOOLS REQUIRED:

- 3/16" Hex Head Wrench
- Snap Ring Pliers
- O-Ring Pick

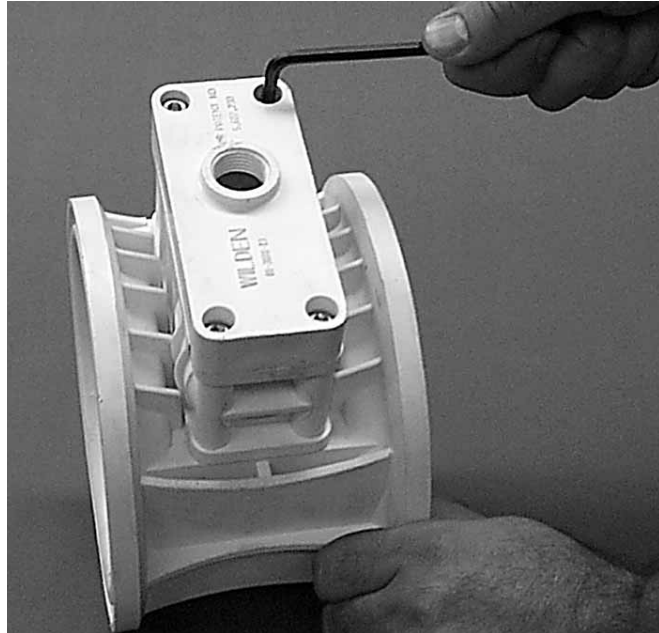

Step 1. *Figure 1*

Loosen the air valve bolts utilizing a 3/16" hex head wrench.

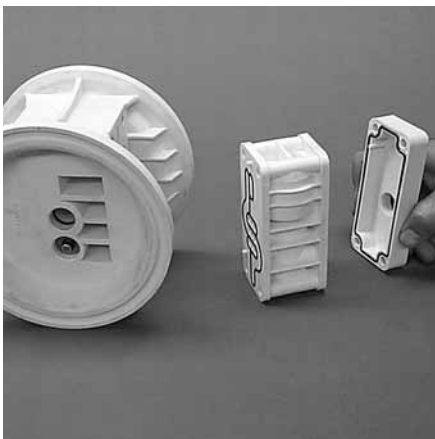

Step 2. *Figure 2*

Remove muffer plate and air valve bolts from air valve assembly exposing muffer gasket for inspection. Replace if necessary.



Step 3. *Figure 3*

Lift away air valve assembly and remove air valve gasket for inspection. Replace if necessary.



Step 4. *Figure 4*

Remove air valve end cap to expose air valve spool by simply lifting up on end cap once air valve bolts are removed.



Step 5. *Figure 5*

Remove air valve spool from air valve body by threading one air valve bolt into the end of the spool and gently sliding the spool out of the air valve body. Inspect seals for signs of wear and replace entire assembly if necessary. Use caution when handling air valve spool to prevent damaging seals.

NOTE: Seals should not be removed from assembly. Seals are not sold separately.



Step 6. *Figure 6*

Remove pilot spool sleeve retaining snap ring on both sides of center section with snap ring pliers.



Step 7. *Figure 7*

Remove pilot spool sleeve from center section.



Step 8. *Figure 8*

With o-ring pick, gently remove pilot spool retaining o-ring. Replace if necessary. Gently remove pilot spool from sleeve and inspect spool and seals for nicks, gouges or other signs of wear. Replace pilot sleeve assembly or outer sleeve o-rings if necessary.

NOTE: Seals should not be removed from pilot spool. Seals are not sold separately.

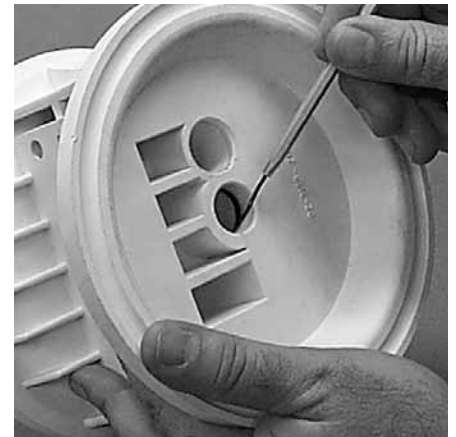

Step 9. *Figure 9*

Check center section Glyd™ rings for signs of wear. If necessary, remove Glyd™ rings with o-ring pick and replace.

REASSEMBLY HINTS & TIPS

ASSEMBLY:

Upon performing applicable maintenance to the air distribution system, the pump can now be reassembled. Please refer to the disassembly instructions for photos and parts placement. To reassemble the pump, follow the disassembly instructions in reverse order. The air distribution system needs to be assembled first, then the diaphragms and finally the wetted path. Please find the applicable torque specifications on this page. The following tips will assist in the assembly process.

- Clean the inside of the center section shaft bore to ensure no damage is done to new seals.
- Stainless bolts should be lubed to reduce the possibility of seizing during tightening.
- Be sure to tighten outer pistons simultaneously on PTFE-fitted pumps to ensure proper torque values.
- Apply two (2) drops of Loctite® 246 to the shaft internal threads before the diaphragm assembly.
- Concave side of disc spring in diaphragm assembly faces **toward** inner piston.

MAXIMUM TORQUE SPECIFICATIONS

Description of Part	Plastic Pumps
Air Valve, Pro-Flo®	3.1 N•m (27 in-lbs)
Air Inlet, Reducer Bushing	0.9 N•m (8 in-lbs)
Outer Piston — Rubber- and PTFE-fitted	27.1 N•m (20 ft-lbs)
Top and Bottom Retainers	14.1 N•m (125 in-lbs)
Large Clamp Band — Rubber-fitted	10.7 N•m (95 in-lbs)
Large Clamp Band — PTFE-fitted	14.1 N•m (125 in-lbs)

GASKET KIT INSTALLATION

PTFE-fitted P2 pumps require expanded PTFE material around the diaphragm bead (P/N 02-9502-99). Carefully prepare sealing surfaces by removing all debris and foreign matter from

diaphragm bead and all mating surfaces. If necessary, smooth or deburr all sealing surfaces. Mating surfaces must be properly aligned in order to ensure positive sealing characteristics.

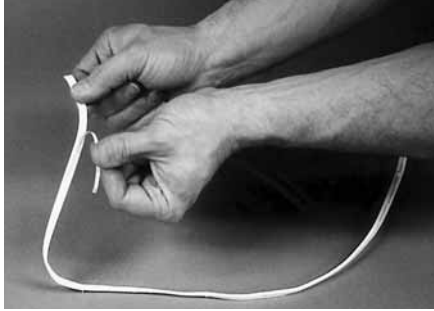

Step 1. *Figure 1*

Gently remove the adhesive covering from the back of the PTFE tape. Ensure that the adhesive strip remains attached to the PTFE tape.

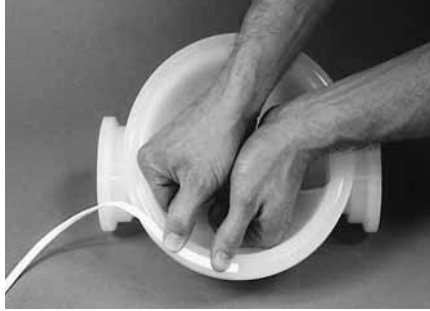

Step 2. *Figure 2*

Starting at any point, place the PTFE tape in the center of the diaphragm bead groove on the liquid chamber and press lightly on the tape to ensure that the adhesive holds it in place during assembly. Do not stretch the tape during placement in center of diaphragm bead groove.



Step 3. *Figure 3*

The ends of the tape should overlap approximately 13 mm (1/2"). Proceed to install the PTFE tape on the remaining liquid chamber.

EXPLODED VIEW & PARTS LISTING

P2 PLASTIC

FULL STROKE DIAPHRAGM-FITTED

EXPLODED VIEW

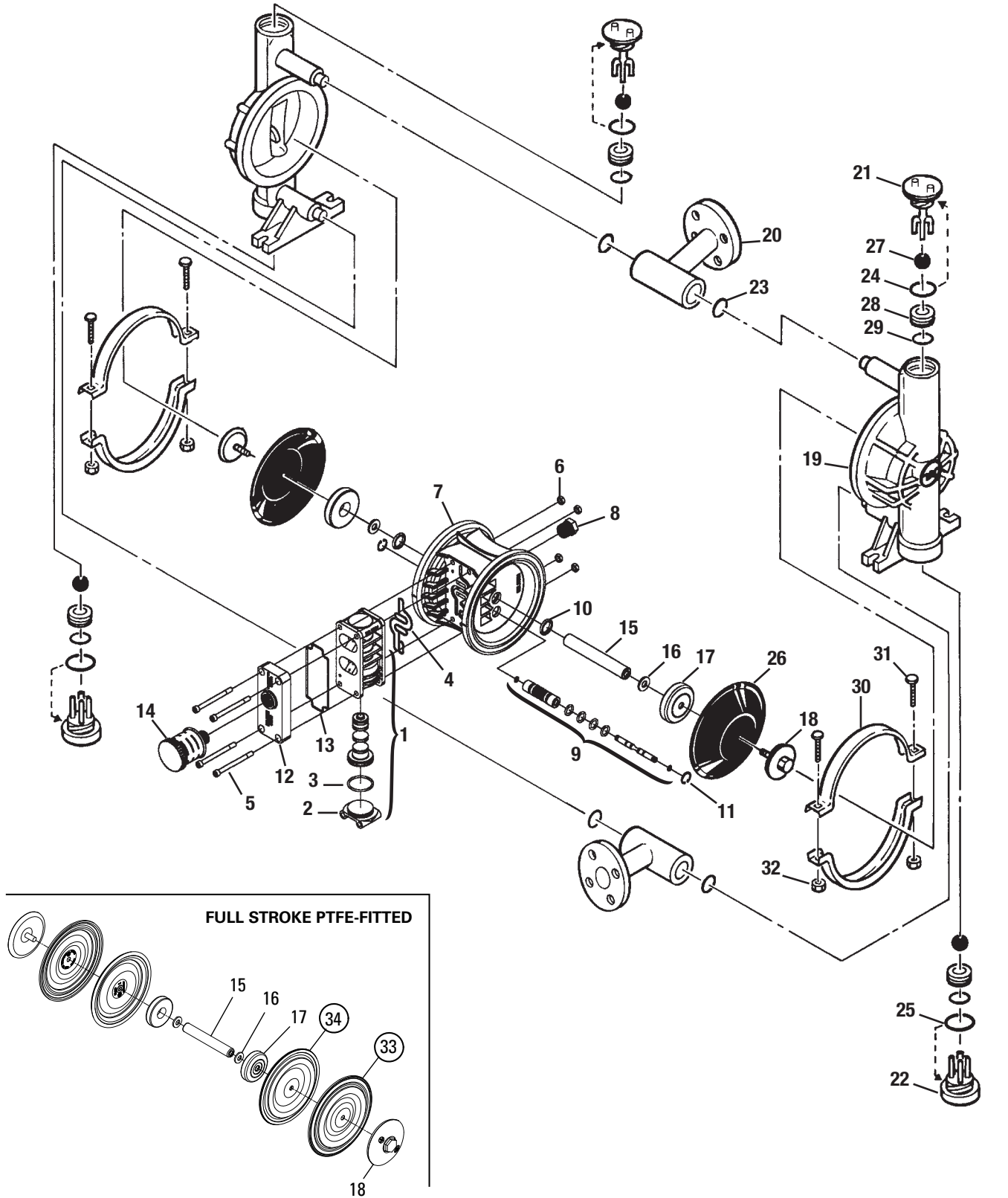

EXPLODED VIEW & PARTS LISTING

P2 PLASTIC

FULL STROKE DIAPHRAGM-FITTED

PARTS LISTING

Item	Part Description	Qty. Per Pump	P2/ PKPPP/0400 P/N	P2/ PKPPP/0402 P/N	P2/ KKPPP/0400 P/N	P2/ KKPPP/0402 P/N
1	Pro-Flo® Air Valve Assembly¹	1	01-2010-20	01-2010-20	01-2010-20	01-2010-20
2	End Cap	1	01-2332-20	01-2332-20	01-2332-20	01-2332-20
3	O-Ring, End Cap	1	01-2395-52	01-2395-52	01-2395-52	01-2395-52
4	Gasket, Air Valve	1	01-2615-52	01-2615-52	01-2615-52	01-2615-52
5	Screw, HSHC, Air Valve 1/4-20	4	01-6001-03	01-6001-05	01-6001-03	01-6001-05
6	Nut, Hex, 1/4"-20	4	04-6400-03	04-6400-05	04-6400-03	04-6400-05
7	Center Section	1	02-3140-20	02-3140-20	02-3140-20	02-3140-20
8	Bushing, Reducer	1	01-6950-20	01-6950-20	01-6950-20	01-6950-20
9	Removable Pilot Sleeve Assembly	1	02-3880-99	02-3880-99	02-3880-99	02-3880-99
10	Glyd™ Ring II	2	02-3210-55-225	02-3210-55-225	02-3210-55-225	02-3210-55-225
11	Retaining Ring	2	00-2650-03	00-2650-03	00-2650-03	00-2650-03
12	Muffler Plate	1	01-3181-20	01-3181-20	01-3181-20	01-3181-20
13	Gasket, Muffler Plate	1	01-3505-52	01-3505-52	01-3505-52	01-3505-52
14	Muffler	1	02-3510-99	02-3510-99	02-3510-99	02-3510-99
15	Shaft, Pro-Flo®	1	02-3810-03	02-3810-03	02-3810-03	02-3810-03
16	Disc Spring (Belleville Washer)	2	02-6802-08	02-6802-08	02-6802-08	02-6802-08
17	Inner Piston	2	02-3701-01	02-3701-01	02-3701-01	02-3701-01
18	Outer Piston	2	02-4550-21-500	02-4550-21-500	02-4550-21-500	02-4550-21-500
19	Liquid Chamber	2	02-5001-20-400	02-5001-20-400	02-5001-21-400	02-5001-21-400
20	Manifold Tee Section	2	02-5160-20-400	02-5160-20-400	02-5160-21-400	02-5160-21-400
21	Top Retainer	2	02-5411-20-400	02-5411-20-400	02-5411-21-400	02-5411-21-400
22	Bottom Retainer	2	02-5420-20-400	02-5420-20-400	02-5420-21-400	02-5420-21-400
23	T-Section O-Ring	4	*	*	*	*
24	Top Retainer O-Ring	2	*	*	*	*
25	Bottom Retainer O-Ring	2	*	*	*	*
26	Diaphragm	2	*	*	*	*
27	Valve Ball	4	*	*	*	*
28	Valve Seat	4	02-1120-20-400	02-1120-20-400	02-1120-21-400	02-1120-21-400
29	Valve Seat O-Ring	4	*	*	*	*
30	Clamp Band Assembly	4	02-7300-03-400	02-7300-05-402	02-7300-03-400	02-7300-05-402
31	Clamp Band Bolt 5/16" 18 x 1-3/4"	4	08-6050-03-500	08-6050-05-500	08-6050-03-500	08-6050-05-500
32	Clamp Band Nut 5/16"-18	4	08-6400-03	08-6400-05	08-6400-03	08-6400-05
33	Diaphragm, Primary Full Stroke PTFE	2	02-1040-55	02-1040-55	02-1040-55	02-1040-55
34	Diaphragm, Backup Full Stroke PTFE	2	*	*	*	*

¹Air Valve Assembly includes items 2 and 3.
*Refer to corresponding elastomer chart in Section 10.
0400 Specialty Code = P2R
0402 Specialty Code = P2R with PFA coating

All boldface items are primary wear parts.

EXPLODED VIEW & PARTS LISTING

P2 PLASTIC

REDUCED STROKE DIAPHRAGM-FITTED

EXPLODED VIEW

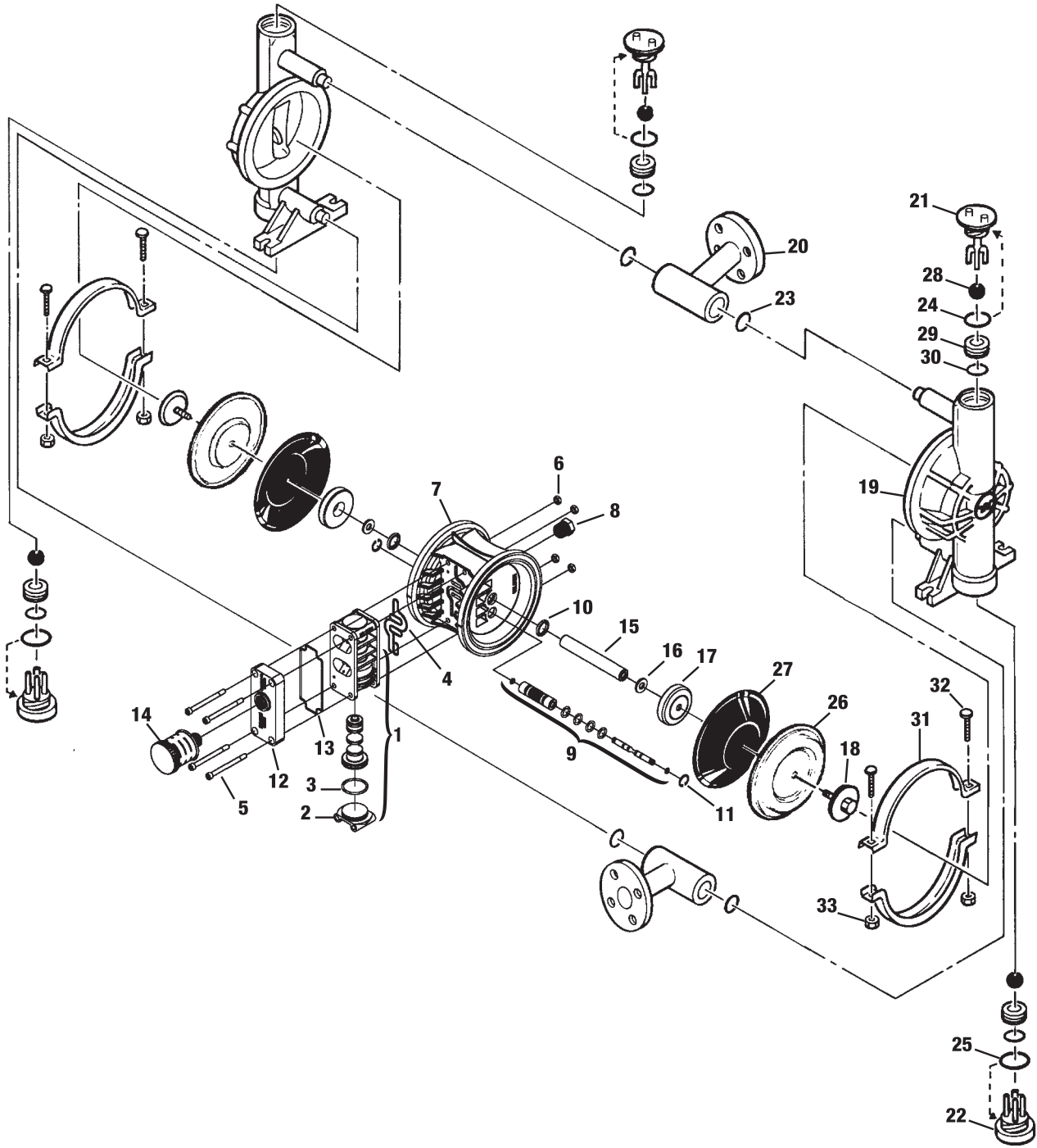

EXPLODED VIEW & PARTS LISTING

P2 PLASTIC

REDUCED STROKE DIAPHRAGM-FITTED

PARTS LISTING

Item	Part Description	Qty. Per Pump	P2/ PKPPP/0400 P/N	P2/ PKPPP/0402 P/N	P2/ KKPPP/0400 P/N	P2/ KKPPP/0402 P/N
1	Pro-Flo® Air Valve Assembly¹	1	01-2010-20	01-2010-20	01-2010-20	01-2010-20
2	End Cap	1	01-2332-20	01-2332-20	01-2332-20	01-2332-20
3	O-Ring, End Cap	1	01-2395-52	01-2395-52	01-2395-52	01-2395-52
4	Gasket, Air Valve	1	01-2615-52	01-2615-52	01-2615-52	01-2615-52
5	Screw, HSHC, Air Valve 1/4-20	4	01-6001-03	01-6001-05	01-6001-03	01-6001-05
6	Nut, Hex, 1/4"-20	4	04-64 00-03	04-6400-05	04-6400-03	04-6400-05
7	Center Section	1	02-3140-20	02-3140-20	02-3140-20	02-3140-20
8	Bushing, Reducer	1	01-6950-20	01-6950-20	01-6950-20	01-6950-20
9	Removable Pilot Sleeve Assembly	1	02-3880-99	02-3880-99	02-3880-99	02-3880-99
10	Glyd™ Ring II	2	02-3210-55-225	02-3210-55-225	02-3210-55-225	02-3210-55-225
11	Retaining Ring	2	00-2650-03	00-2650-03	00-2650-03	00-2650-03
12	Muffler Plate	1	01-3181-20	01-3181-20	01-3181-20	01-3181-20
13	Gasket, Muffler Plate	1	01-3505-52	01-3505-52	01-3505-52	01-3505-52
14	Muffler	1	02-3510-99	02-3510-99	02-3510-99	02-3510-99
15	Shaft, Pro-Flo®	1	02-3840-03	02-3840-03	02-3840-03	02-3840-03
16	Disc Spring (Belleville Washer)	2	02-6802-08	02-6802-08	02-6802-08	02-6802-08
17	Inner Piston	2	02-3751-01	02-3751-01	02-3751-01	02-3751-01
18	Outer Piston	2	02-4600-21-500	02-4600-21-500	02-4600-21-500	02-4600-21-500
19	Liquid Chamber	2	02-5001-20-400	02-5001-20-400	02-5001-21-400	02-5001-21-400
20	Manifold Tee Section	2	02-5160-20-400	02-5160-20-400	02-5160-21-400	02-5160-21-400
21	Top Retainer	2	02-5411-20-400	02-5411-20-400	02-5411-21-400	02-5411-21-400
22	Bottom Retainer	2	02-5420-20-400	02-5420-20-400	02-5420-21-400	02-5420-21-400
23	T-Section O-Ring	4	02-1300-60-400	02-1300-60-400	02-1300-60-400	02-1300-60-400
24	Top Retainer O-Ring	2	02-1220-60	02-1220-60	02-1220-60	02-1220-60
25	Bottom Retainer O-Ring	2	02-1230-60	02-1230-60	02-1230-60	02-1230-60
26	Diaphragm	2	02-1010-55	02-1010-55	02-1010-55	02-1010-55
27	Backup Diaphragm	2	*	*	*	*
28	Valve Ball	4	02-1080-55	02-1080-55	02-1080-55	02-1080-55
29	Valve Seat	4	02-1120-20-400	02-1120-20-400	02-1120-21-400	02-1120-21-400
30	Valve Seat O-Ring	4	02-1200-60-400	02-1200-60-400	02-1200-60-400	02-1200-60-400
31	Clamp Band Assembly	4	02-7300-03-400	02-7300-05-402	02-7300-03-400	02-7300-05-402
32	Clamp Band Bolt 5/16" 18 x 1-3/4"	4	08-6050-03-500	08-6050-05-500	08-6050-03-500	08-6050-05-500
33	Clamp Band Nut 5/16"-18	4	08-6400-03	08-6400-05	08-6400-03	08-6400-05

¹Air Valve Assembly includes items 2 and 3.

*Refer to corresponding elastomer chart in Section 10.

0400 Specialty Code = P2R

0402 Specialty Code = P2R with PFA coating

All boldface items are primary wear parts.

ELASTOMER OPTIONS

ELASTOMER OPTIONS FOR MODEL P2 PLASTIC PUMPS

Material	Diaphragm P/N (2)	Reduced Stroke Backup Diaphragm (2)	Full Stroke Backup Diaphragm (2)	Valve Ball P/N (4)	Valve Seat O-Ring P/N (4)	Tee Section O-Ring P/N (4)	Top Retainer O-Ring P/N (2)	Bottom Retainer O-Ring P/N (2)
Polyurethane	02-1010-50	N/A	N/A	02-1080-50	02-1200-50-400	02-1300-50-400	02-1220-50	02-1230-50
Buna-N	02-1010-52	N/A	N/A	02-1080-52	08-2390-52	04-2390-52	04-2390-52-700	02-1230-52
PTFE Encapsulated Viton®	N/A	N/A	N/A	N/A	02-1200-60-400	02-1300-60-400	02-1220-60	02-1230-60
Neoprene	02-1010-51	02-1060-51	N/A	02-1080-51	N/A	N/A	N/A	N/A
Viton®	02-1010-53	N/A	N/A	02-1080-53	N/A	N/A	N/A	N/A
EPDM	02-1010-54	N/A	N/A	02-1080-54	N/A	N/A	N/A	N/A
PTFE	02-1010-55	N/A	N/A	02-1080-55	N/A	N/A	N/A	N/A
Full Stroke PTFE	02-1040-55	N/A	N/A	02-1080-55	N/A	N/A	N/A	02-1045-57
Tetra-Flex™ PTFE, Neoprene Backed	02-1010-64	N/A	N/A	N/A	N/A	N/A	N/A	N/A
Tetra-Flex™ PTFE, EPDM Backed	02-1010-81	N/A	N/A	N/A	N/A	N/A	N/A	N/A
Saniflex™	02-1010-56	02-1060-56	02-1065-56	02-1080-56	N/A	N/A	N/A	N/A
Wil-Flex™	02-1010-58	N/A	02-1065-57	02-1080-58	02-1200-58-400	02-1300-58-400	02-1220-58	02-1230-58

*Backup diaphragms for use with PTFE diaphragms only.

NOTES

NOTES

WARRANTY

Each and every product manufactured by Wilden Pump and Engineering, LLC is built to meet the highest standards of quality. Every pump is functionally tested to insure integrity of operation.

Wilden Pump and Engineering, LLC warrants that pumps, accessories and parts manufactured or supplied by it to be free from defects in material and workmanship for a period of five (5) years from date of installation or six (6) years from date of manufacture, whichever comes first. Failure due to normal wear, misapplication, or abuse is, of course, excluded from this warranty.

Since the use of Wilden pumps and parts is beyond our control, we cannot guarantee the suitability of any pump or part for a particular application and Wilden Pump and Engineering, LLC shall not be liable for any consequential damage or expense arising from the use or misuse of its products on any application. Responsibility is limited solely to replacement or repair of defective Wilden pumps and parts.

All decisions as to the cause of failure are the sole determination of Wilden Pump and Engineering, LLC.

Prior approval must be obtained from Wilden for return of any items for warranty consideration and must be accompanied by the appropriate MSDS for the product(s) involved. A Return Goods Tag, obtained from an authorized Wilden distributor, must be included with the items which must be shipped freight prepaid.

The foregoing warranty is exclusive and in lieu of all other warranties expressed or implied (whether written or oral) including all implied warranties of merchantability and fitness for any particular purpose. No distributor or other person is authorized to assume any liability or obligation for Wilden Pump and Engineering, LLC other than expressly provided herein.

PLEASE PRINT OR TYPE AND FAX TO WILDEN

PUMP INFORMATION			
Item # _____		Serial # _____	
Company Where Purchased _____			
YOUR INFORMATION			
Company Name _____			
Industry _____			
Name _____		Title _____	
Street Address _____			
City _____		State _____	Postal Code _____
Country _____			
Telephone _____		Fax _____	E-mail _____
Web Address _____			
Number of pumps in facility? _____		Number of Wilden pumps? _____	
Types of pumps in facility (check all that apply): <input type="checkbox"/> Diaphragm <input type="checkbox"/> Centrifugal <input type="checkbox"/> Gear <input type="checkbox"/> Submersible <input type="checkbox"/> Lobe			
<input type="checkbox"/> Other _____			
Media being pumped? _____			
How did you hear of Wilden Pump? <input type="checkbox"/> Trade Journal <input type="checkbox"/> Trade Show <input type="checkbox"/> Internet/E-mail <input type="checkbox"/> Distributor			
<input type="checkbox"/> Other _____			

ONCE COMPLETE, FAX TO (909) 783-3440

NOTE: WARRANTY VOID IF PAGE IS NOT FAXED TO WILDEN
WILDEN PUMP & ENGINEERING, LLC

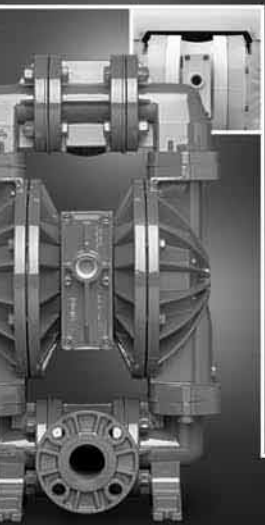

ADVANCED S E R I E S

Advance Your Process

- Advanced wetted path designs
- Lower the cost of operation
- Maximize product containment
- Longer MTBF (Mean Time Between Failures)
- Enhanced internal clearance
- The result of advanced thought

UNITEC S E R I E S

Enrich Your Process

- Simplicity of design
- Unique Technology
- Reliable, leak-free & quiet
- Validated & certified
- Intrinsically safe
- The result of unique thought

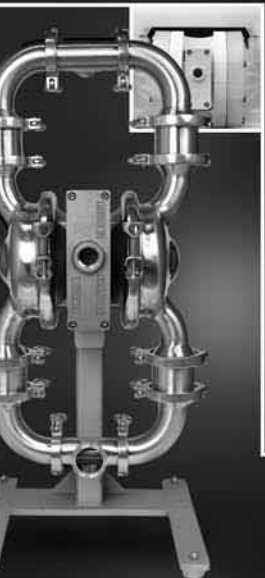
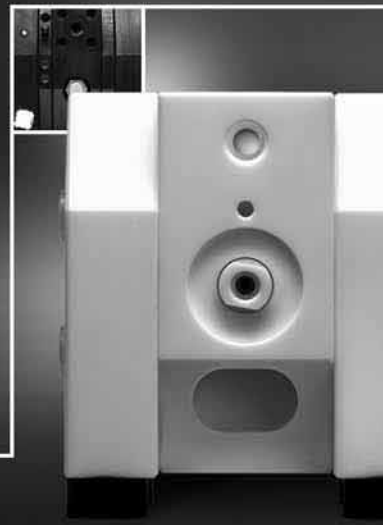

SANIFLO S A N I T A R Y P U M P T E C H N O L O G Y

Refine Your Process

- Designed for sanitary applications
- Minimize product degradation
- Improved production yields
- Easy to inspect, clean & assemble
- Minimized water requirements
- The result of progressive thought

ACCESSORIES

Maximize Your Process

- Electronic control & monitoring
- Level control & containment
- Pulsation dampening
- Drum unloading systems
- Complete system solutions
- The result of innovative thought

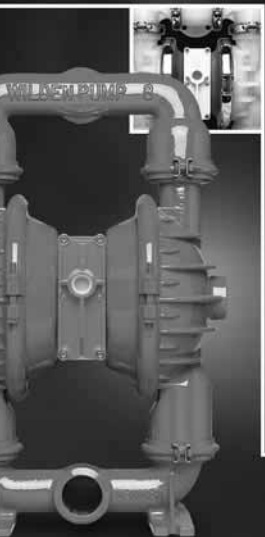

ORIGINAL S E R I E S

Simplify Your Process

- Long standing design simplicity
- Portable & submersible
- Variable connection options
- Fewest parts in industry
- Solutions since 1955
- The result of original thought



WILDEN[®]

A **DOVER** COMPANY

22069 VAN BUREN STREET • GRAND TERRACE, CA 92313-5607
(909) 422-1730 • FAX (909) 783-3440
www.wildenpump.com

Your Local Authorized Distributor: