

PUMP STATION CONTROLLERS - AUXILLARY EQUIPMENT

BMS/RSI/SMS

DESCRIPTION

- External alarm equipment to provide remote alarms as required
- Options include BMS, RSI and SMS management systems

CONSTRUCTION/FEATURES

BMS - (Building Management System)

- Interface for SPC and DPC controllers
- 4 Output Relays - Pump 1, Pump 2, High Level Faults, Power Fail

RSI - (Remote Status Indicator)

- For SPC and DPC Controllers
- Indication of power on, high level and pump faults
- Mute button, built in buzzer

SMS - (Smart Message System) - Alarm Sender

- Send text messages when pump station fault,
- 4 output relays
- Up to 5 separate cell phone numbers to send descriptive messages to
- Dual and single pump controller compatible

APPLICATIONS

- Sewage Pumps/Pumping Stations
- Stormwater Pumps/Pumping Stations
- Constant Pressure Pumps/Pumping Stations
- Hot Water Circulation Systems
- Transfer Pumping Systems

Model	Description
FPC-30110	BMS Module
FPC-15100	Remote Status - Single Pump
FPC-30100	Remote Status - Dual Pump
FPC-30120	SMS Alarm Sender

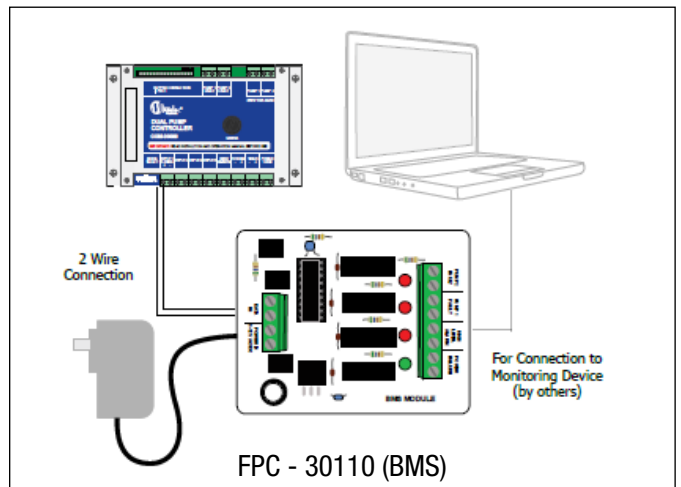

FPC - 15100



FPC - 30100

