

A1

Engineering Operation & Maintenance

CE

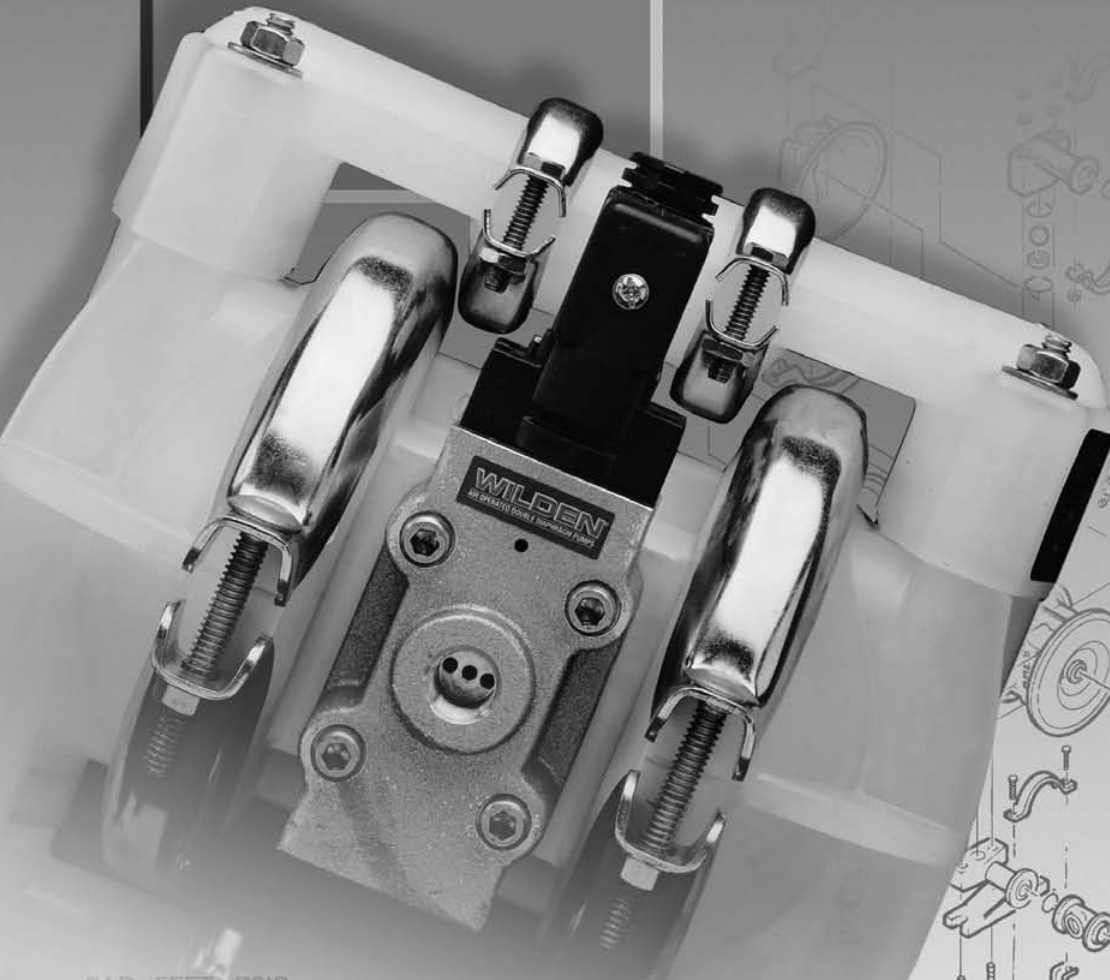

WILDEN®

A DOVER COMPANY

ACCUFLO™

SOLENOID PUMP TECHNOLOGY

Plastic Pumps

TABLE OF CONTENTS

	PAGE #
SECTION # 1 — WILDEN PUMP DESIGNATION SYSTEM	1
SECTION # 2 — THE WILDEN PUMP - HOW IT WORKS	2
SECTION # 3 — CAUTIONS — READ FIRST!	3
SECTION # 4 — DIMENSIONAL DRAWINGS	
A. Model A1T PLASTIC (T-series Center Section)	4
B. Model A1B PLASTIC (Adapter Block with T-series Center Section)	4
C. Model A1P PLASTIC (P-series Center Section)	5
D. Model A1B PLASTIC (Adapter Block with P-series Center Section)	5
SECTION # 5 — PERFORMANCE CURVES	
A. Model A1T PLASTIC Rubber Fitted (T-series Center Section)	6
B. Model A1T PLASTIC PTFE Fitted (T-series Center Section)	6
C. Model A1P PLASTIC Rubber Fitted (P-series Center Section)	7
D. Model A1P PLASTIC PTFE Fitted (P-series Center Section)	7
SECTION # 6 — 70/30 OPERATING CONDITION	
A. Model A1T PLASTIC Rubber Fitted (T-series Center Section)	8
A. Model A1T PLASTIC PTFE Fitted (T-series Center Section)	8
B. Model A1P PLASTIC Rubber Fitted (P-series Center Section)	8
B. Model A1P PLASTIC PTFE Fitted (P-series Center Section)	8
SECTION # 7 — INSTALLATION & OPERATION	
A. Installation Accu-Flo	9
B. Operating Principals	10
C. Operation & Maintenance	10
D. Troubleshooting	11
SECTION # 8 — DIRECTIONS FOR DISASSEMBLY/REASSEMBLY	
A. Models A1T & A1P & A1B Plastic - Wetted Path	12
B. Reassembly Hints & Tips	15
C. Gasket Kit Installation	16
SECTION # 9 — EXPLODED VIEW/PARTS LISTING	
A. Model A1T PLASTIC (T-series Center Section)	18
B. Model A1P PLASTIC (P-series Center Section)	20
SECTION # 10 — ELASTOMER OPTIONS/ ELECTRICAL INFORMATION	
A. Elastomer Options	22
B. Electrical Information	23

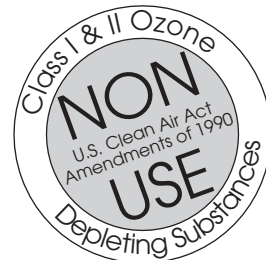

SECTION 1

WILDEN PUMP DESIGNATION SYSTEM

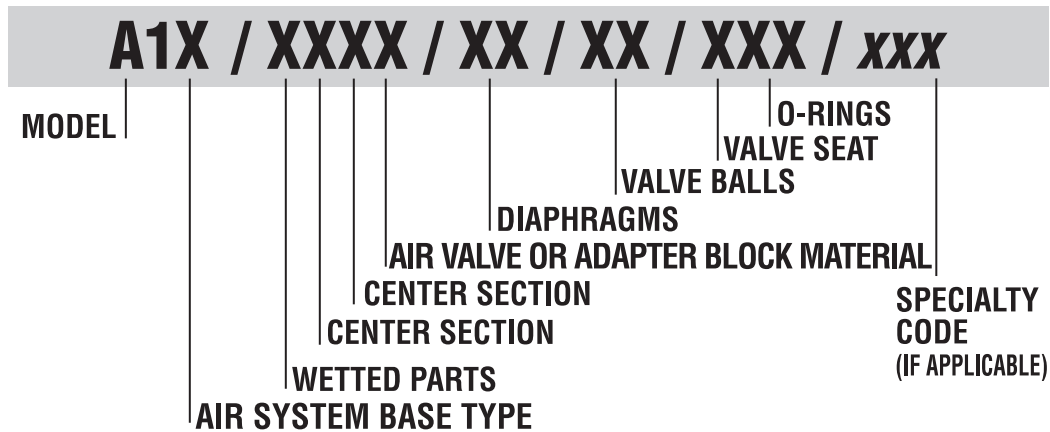

MODEL A1 PLASTIC MATERIAL CODES

AIR SYSTEM BASE TYPE

- T = TURBO-FLO™
- P = PRO-FLO™
- B = ADAPTER BLOCK

WETTED PARTS

- K = PVDF
- P = POLYPROPYLENE

CENTER SECTION

- PP = POLYPROPYLENE

AIR VALVE

- A = ALUMINUM (available for A1T only)
- P = POLYPROPYLENE
- U = UHMW (available for A1B only)
- L = ACETAL (Available for A1B and A1P only)

DIAPHRAGMS

- BN = BUNA-N (Red Dot)
- FG = SANIFLEX™ (Cream)
- PU = POLYURETHANE (Clear)
- TF = TEFLON® PTFE (White)
- VT = VITON® (Silver or White Dot)
- WF = WIL-FLEX™ (Orange)

VALVE BALL

- BN = BUNA-N (Red Dot)
- FG = SANIFLEX™
- PU = POLYURETHANE (Brown)
- TF = TEFLON® PTFE (White)
- VT = VITON® (Silver or White Dot)
- WF = WIL-FLEX™ (Orange)

VALVE SEAT

- K = PVDF
- VT = VITON®

VALVE SEAT O-RING

- BN = BUNA-N (Red Dot)
- FG = SANIFLEX™ (Cream)
- PU = POLYURETHANE (Brown)
- TV = TEFLON® ENCAP. VITON®
- WF = WIL-FLEX™ (Orange)

NOTE: MOST ELASTOMERIC MATERIALS USE COLORED DOTS FOR IDENTIFICATION.

SECTION 2

THE WILDEN PUMP — HOW IT WORKS

The Wilden diaphragm pump is an air-operated, positive displacement, self-priming pump. These drawings show the flow pattern through the pump upon its initial stroke. It is assumed the pump has no fluid in it prior to its initial stroke.

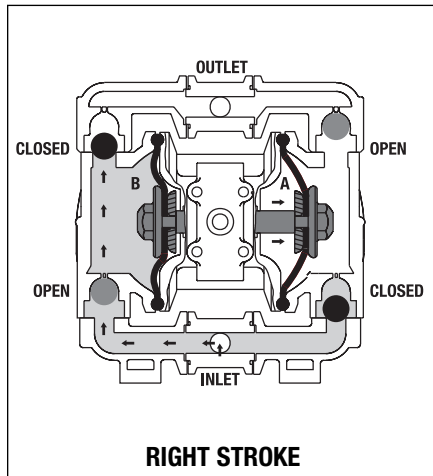

RIGHT STROKE

FIGURE 1 When the solenoid is energized, the air valve directs pressure to the back side of diaphragm A. The compressed air is applied directly to the liquid column separated by elastomeric diaphragms. The diaphragm acts as a membrane between the compressed air and the liquid, balancing the load and removing mechanical stress from the diaphragm. The compressed air moves the diaphragm away from the center section of the pump. The opposite diaphragm is pulled in by the shaft connected to the pressurized diaphragm. Diaphragm B is on its suction stroke; air behind the diaphragm has been forced out to the atmosphere through the exhaust port. The movement of diaphragm B toward the center section of the pump creates a vacuum within chamber B. Atmospheric pressure forces fluid into the inlet manifold forcing the inlet valve ball off of its seat. Liquid is free to move past the inlet valve ball and fill the liquid chamber (see shaded area).

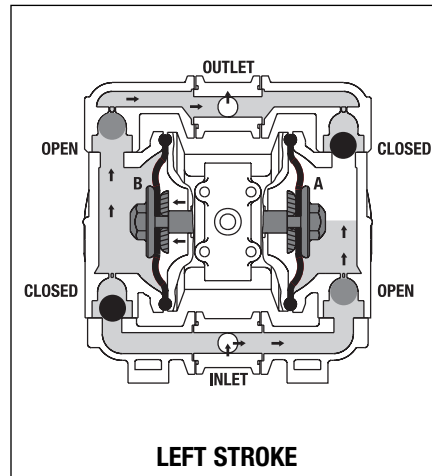

LEFT STROKE

FIGURE 2 When the solenoid valve is deenergized, the air valve redirects pressurized air to the back side of diaphragm B. The pressurized air forces diaphragm B away from the center section while pulling diaphragm A to the center section. Diaphragm B is now on its discharge stroke. Diaphragm B forces the inlet valve ball onto its seat due to the hydraulic forces developed in the liquid chamber and manifold of the pump. These same hydraulic forces lift the discharge valve ball off of its seat, while the opposite discharge valve ball is forced onto its seat, forcing fluid to flow through the pump discharge. The movement of diaphragm A toward the center section of the pump creates a vacuum within liquid chamber A. Atmospheric pressure forces fluid into the inlet manifold of the pump. The inlet valve ball is forced off of its seat allowing the fluid being pumped to fill the liquid chamber.

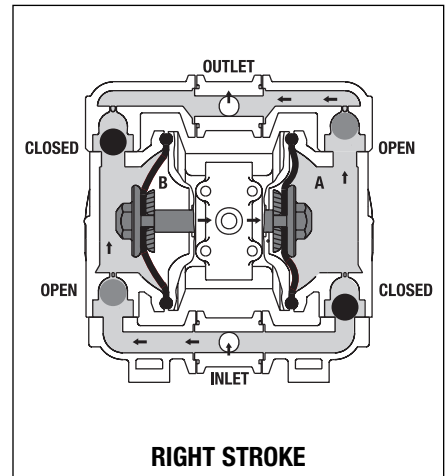

RIGHT STROKE

FIGURE 3 Once the solenoid valve is reenergized, the air is redirected to the back side of diaphragm A, which starts diaphragm B on its exhaust stroke. As the pump reaches its original starting point, each diaphragm has gone through one intake and one discharge stroke. This constitutes one complete pumping cycle. The pump may take several cycles to completely prime depending on the conditions of the application.

SECTION 3

WILDEN MODEL A1 PLASTIC CAUTIONS – READ FIRST!



TEMPERATURE LIMITS:

Polypropylene	0°C to 79°C	32°F to 175°F
PVDF	-12°C to 107°C	10°F to 225°F
Neoprene	-17.8°C to 93.3°C	0°F to 200°F
Buna-N	-12.2°C to 82.2°C	10°F to 180°F
Viton®	-40°C to 176.7°C	-40°F to 350°F
Wil-Flex™	-40°C to 107.2°C	-40°F to 225°F
Polyurethane	12.2°C to 65.6°C	10°F to 150°F
Saniflex™	-28.9°C to 104.4°C	-20°F to 220°F
Teflon® PTFE	4.4°C to 104.4°C	40°F to 220°F



CAUTION: When choosing pump materials, be sure to check the temperature limits for all wetted components. Example: Viton® has a maximum limit of 176.7°C (350°F) but polypropylene has a maximum limit of only 79°C (175°F).



CAUTION: Maximum temperature limits are based upon mechanical stress only. Certain chemicals will significantly reduce maximum safe operating temperatures. Consult engineering guide for chemical compatibility and temperature limits.



CAUTION: Always wear safety glasses when operating pump. If diaphragm rupture occurs, material being pumped may be forced out air exhaust.



WARNING: Prevention of static sparking — If static sparking occurs, fire or explosion could result. Pump, valves, and containers must be properly grounded when handling flammable fluids and whenever discharge of static electricity is a hazard.



CAUTION: Do not exceed 8.6 Bar (125) psig air supply pressure.



CAUTION: Plastic series pumps are made of virgin plastic and are not UV stabilized. Direct sunlight for prolonged periods can cause deterioration of plastics.



CAUTION: Before any maintenance or repair is attempted, the compressed air line to the pump should be disconnected and all air pressure allowed to bleed from pump. Disconnect all intake, discharge and air lines. Drain the pump by turning it upside down and allowing any fluid to flow into a suitable container.



CAUTION: Blow out air line for 10 to 20 seconds before attaching to pump to make sure all pipe line debris is clear. Use an in-line air filter. A 5µ (micron) air filter is recommended.



NOTE: Tighten clamp bands and other fasteners prior to installation. Fittings may loosen during transportation.



NOTE: When installing Teflon® diaphragms, it is important to tighten outer pistons simultaneously (turning in opposite directions) to ensure tight fit.



NOTE: Before starting disassembly, mark a line from each liquid chamber to its corresponding air chamber. This line will assist in proper alignment during reassembly.



CAUTION: Verify the chemical compatibility of the process and cleaning fluid to the pump's component materials in the Chemical Resistance Guide (see E4).



CAUTION: Only explosion proof (NEMA 7) solenoid valves should be used in areas where explosion proof equipment is required.



CAUTION: Do not lubricate lube-free pumps.



NOTE: A1 Plastic Teflon®-fitted pumps come standard from the factory with expanded Teflon® gaskets. (See Gasket Kit Installation in Section 8C.)



CAUTION: Do not over-tighten the air inlet reducer bushing. Too much torque on the reducer bushing may cause damage. Do not exceed .9 N-m (8 in.-lbs.).



CAUTION: The A1 pump is not submersible.

SECTION 4A

DIMENSIONAL DRAWING

WILDEN MODEL A1T PLASTIC CHAMP ACCU-FLO™

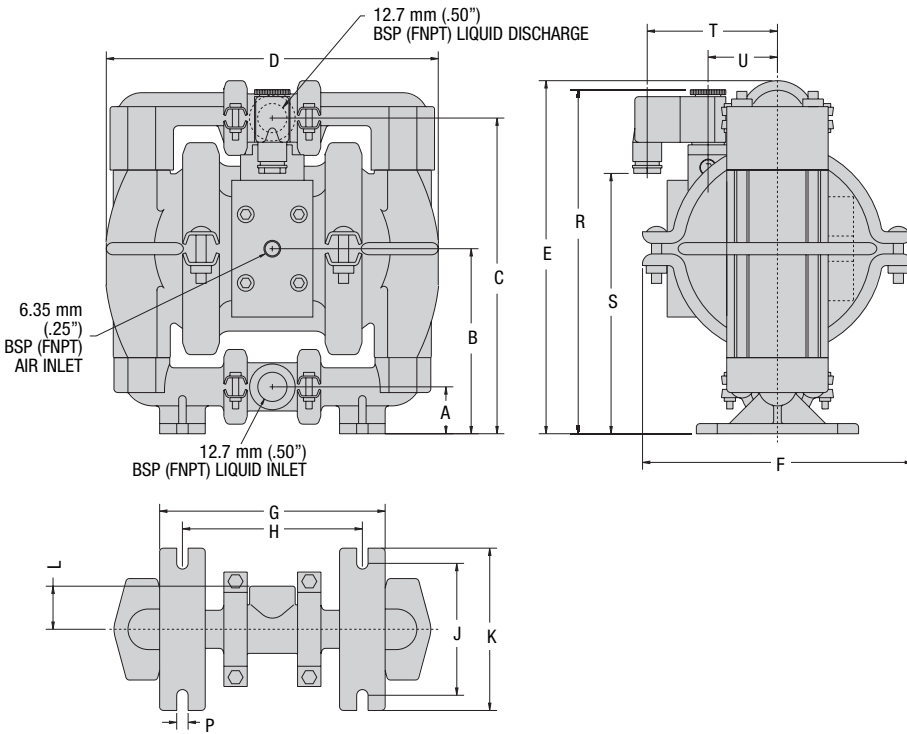

DIMENSIONS – A1T - ACCU-FLO™ (PLASTIC)		
ITEM	METRIC (mm)	STANDARD (inch)
A	30	1.16
B	114	4.50
C	196	7.69
D	208	8.19
E	218	8.63
F	118	7.00
G	145	5.66
H	114	4.50
J	84	3.25
K	102	4.00
L	28	1.09
N	84	3.31
P	8	.28
R	213	8.38
S	160	6.31
T	81	3.22
U	46	1.75

SECTION 4B

DIMENSIONAL DRAWING

WILDEN MODEL A1B PLASTIC CHAMP (T-SERIES CENTER SECTION)

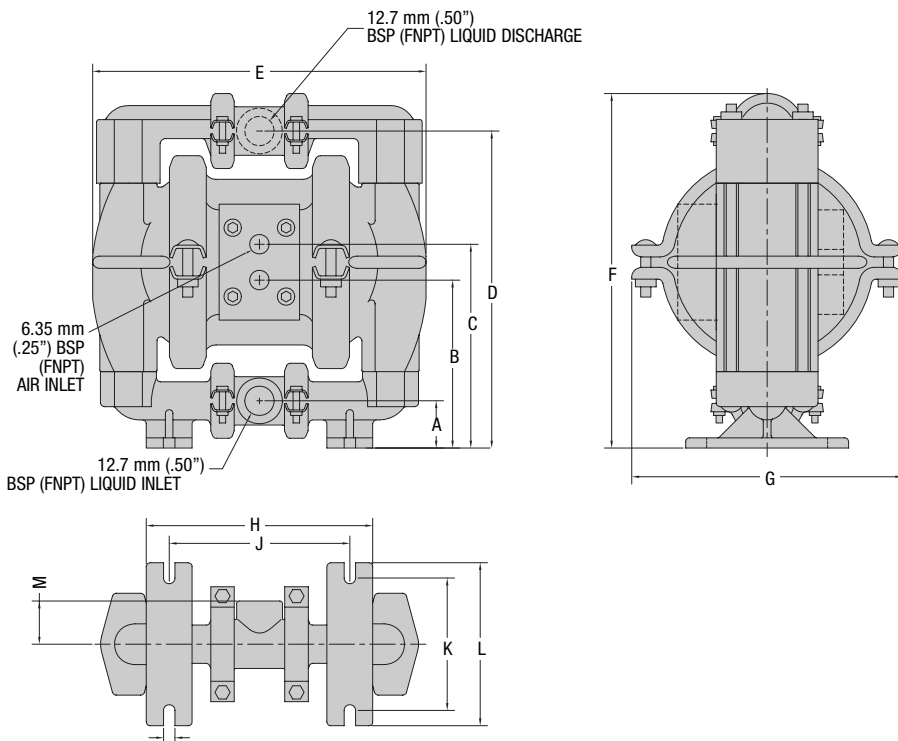

DIMENSIONS – A1B ACCU-FLO™ (PLASTIC)		
ITEM	METRIC (mm)	STANDARD (inch)
A	30	1.16
B	104	4.06
C	124	4.94
D	196	7.69
E	208	8.19
F	218	8.63
G	118	7.00
H	145	5.66
J	114	4.50
K	84	3.25
L	102	4.00
M	28	1.09
P	8	.28

SECTION 4C

DIMENSIONAL DRAWING

WILDEN MODEL A1P PLASTIC CHAMP ACCU-FLO™

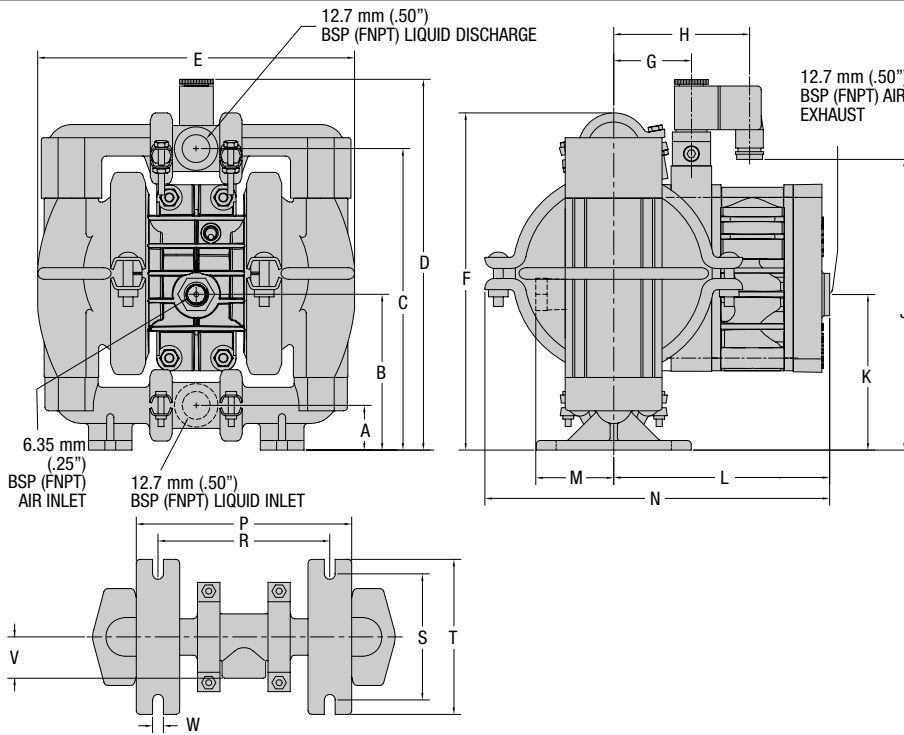

DIMENSIONS – A1P ACCU-FLO (PLASTIC)		
ITEM	METRIC (mm)	STANDARD (inch)
A	30	1.16
B	117	4.59
C	196	7.69
D	244	9.56
E	208	8.19
F	218	8.63
G	51	2.00
H	89	3.50
J	191	7.50
K	117	4.56
L	142	5.56
M	56	2.16
N	231	9.06
P	145	5.66
R	114	4.50
S	84	3.25
T	102	4.00
V	28	1.09
W	8	.28

SECTION 4D

DIMENSIONAL DRAWING

WILDEN MODEL A1B PLASTIC CHAMP (P-SERIES CENTER SECTION)

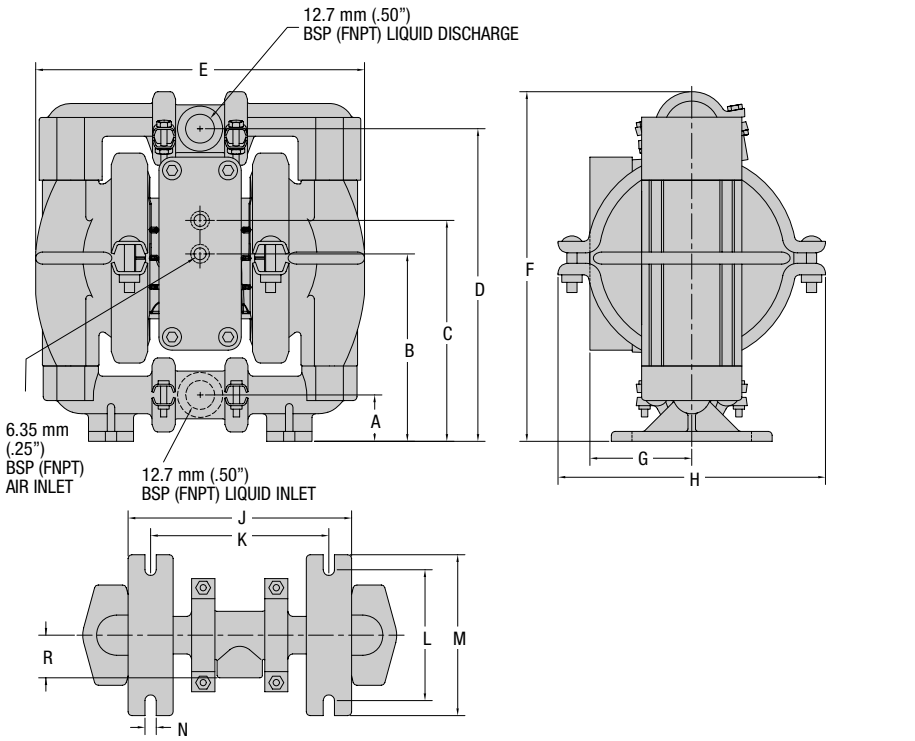

DIMENSIONS – A1B ACCU-FLO (PLASTIC)		
ITEM	METRIC (mm)	STANDARD (inch)
A	30	1.16
B	117	4.59
C	140	5.50
D	196	7.69
E	208	8.19
F	218	8.63
G	64	2.53
H	118	6.88
J	145	5.66
K	114	4.50
L	884	3.25
M	102	4.00
N	8	.28
R	28	1.09

SECTION 5A

PERFORMANCE CURVES

MODEL A1T PLASTIC RUBBER-FITTED

Height218 mm (8.63")
 Width208 mm (8.19")
 Depth118 mm (7.00")
 Ship WeightPolypropylene 4.1 kg (9 lbs.)
 PVDF 5.1 kg (11 lbs.)
 Air Inlet6.35 mm (1/4")
 Inlet12.7 mm (1/2")
 Outlet12.7 mm (1/2")
 Suction Lift4.49 m Dry (15')
 9.33 m Wet (31')

Displacement per Stroke06 l (.015 gal.)¹
 Max. Flow Rate33.4 lpm (9.1 gpm)
 Max. Size Solids.....1.59 mm (1/16")
¹Displacement per stroke was calculated at 4.8 Bar (70 psig) air inlet pressure against a 2 Bar (30 psig) head pressure.

Example: To pump 18.9 lpm (5 gpm) against a discharge head pressure of 2.2 Bar (32 psig) requires 4.1 Bar (60 psig) and 16.2 Nm³/h (9.5 scfm) air consumption. (See dot on chart.)

Caution: Do not exceed 8.6 Bar (125 psig) air supply pressure.

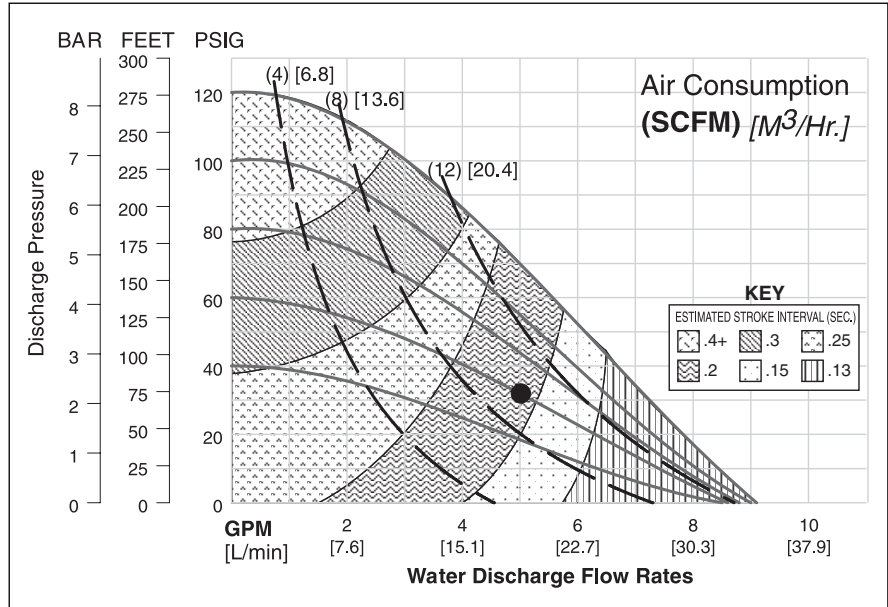

Flow rates indicated on chart were determined by pumping water.

For optimum life and performance, pumps should be specified so that daily operation parameters will fall in the center of the pump performance curve.

SECTION 5B

PERFORMANCE CURVES

MODEL A1T PLASTIC TEFLON[®]-FITTED

Height218 mm (8.63")
 Width208 mm (8.19")
 Depth118 mm (7.00")
 Ship WeightPolypropylene 4.1 kg (9 lbs.)
 PVDF 5.1 kg (11 lbs.)
 Air Inlet6.35 mm (1/4")
 Inlet12.7 mm (1/2")
 Outlet12.7 mm (1/2")
 Suction Lift3.46 m Dry (11')
 9.33 m Wet (31')

Displacement per Stroke06 l (.014 gal.)¹
 Max. Flow Rate29.1 lpm (7.7 gpm)
 Max. Size Solids.....1.59 mm (1/16")
¹Displacement per stroke was calculated at 4.8 Bar (70 psig) air inlet pressure against a 2 Bar (30 psig) head pressure.

Example: To pump 18.9 lpm (5 gpm) against a discharge head pressure of 1.7 Bar (25 psig) requires 4.1 Bar (60 psig) and 17 Nm³/h (10 scfm) air consumption. (See dot on chart.)

Caution: Do not exceed 8.6 Bar (125 psig) air supply pressure.

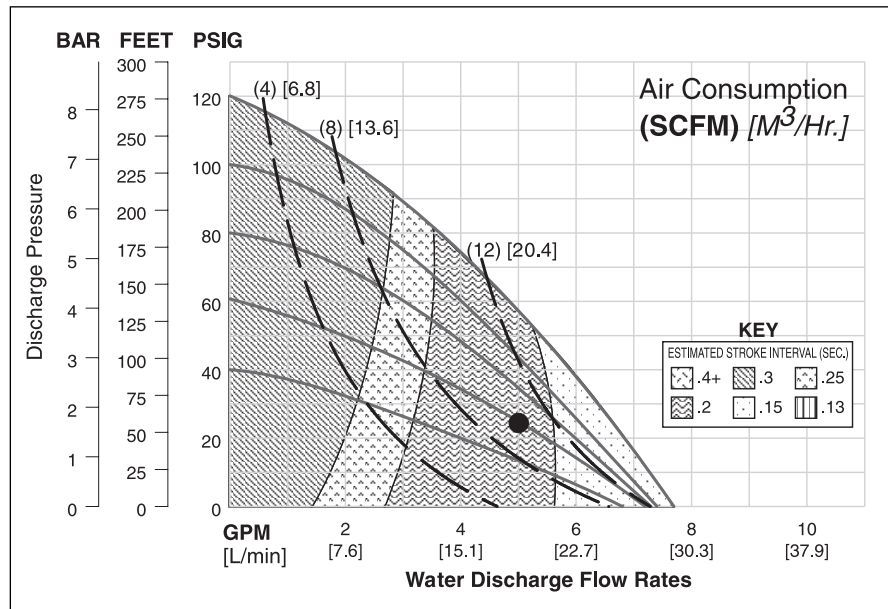

Flow rates indicated on chart were determined by pumping water.

For optimum life and performance, pumps should be specified so that daily operation parameters will fall in the center of the pump performance curve.

SECTION 5C

PERFORMANCE CURVES

MODEL A1P PLASTIC RUBBER-FITTED

Height244 mm (9.56")
Width208 mm (8.19")
Depth231 mm (9.06")
Ship WeightPolypropylene 4.1 kg (9 lbs.)
 PVDF 5.1 kg (11 lbs.)
Air Inlet6.35 mm (1/4")
Inlet12.7 mm (1/2")
Outlet12.7 mm (1/2")
Suction Lift6.05 m Dry (20')
 8.99 m Wet (29')

Displacement per
Stroke 12 l (.032 gal.)¹
Max. Flow Rate39.0 lpm (10.3 gpm)
Max. Size Solids.....1.59 mm (1/16")
¹Displacement per stroke was calculated at 4.8 Bar (70 psig) air inlet pressure against a 2 Bar (30 psig) head pressure.

Example: To pump 18.9 lpm (5 gpm) against a discharge head pressure of 2.7 Bar (39 psig) requires 4.1 Bar (60 psig) and 11.1 Nm³/h (6.5 scfm) air consumption. (See dot on chart.)

Caution: Do not exceed 8.6 Bar (125 psig) air supply pressure.

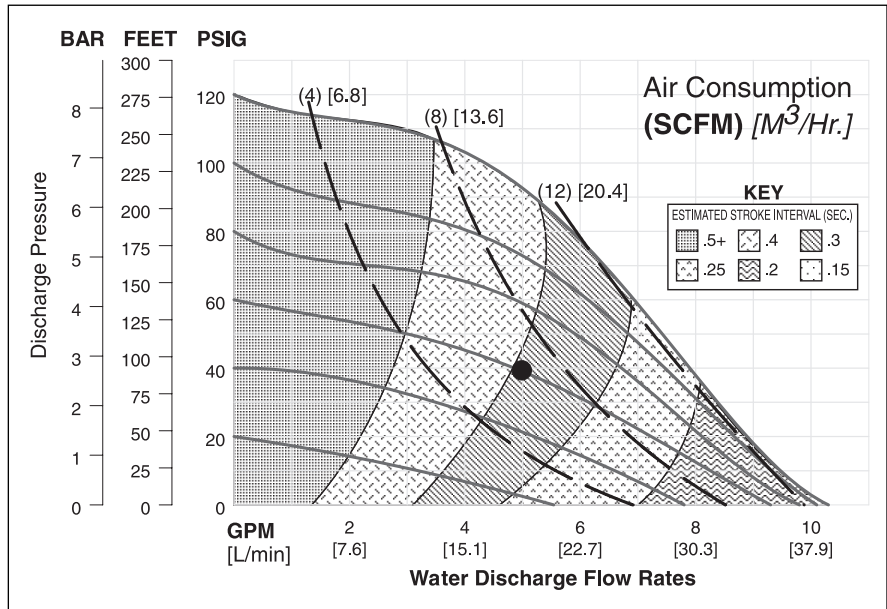

Flow rates indicated on chart were determined by pumping water.

For optimum life and performance, pumps should be specified so that daily operation parameters will fall in the center of the pump performance curve.

SECTION 5D

PERFORMANCE CURVES

MODEL A1P PLASTIC TEFLON[®]-FITTED

Height244 mm (9.56")
Width208 mm (8.19")
Depth231 mm (9.06")
Ship WeightPolypropylene 4.1 kg (9 lbs.)
 PVDF 5.1 kg (11 lbs.)
Air Inlet6.35 mm (1/4")
Inlet12.7 cm (1/2")
Outlet12.7 cm (1/2")
Suction Lift5.18 m Dry (17')
 8.99 m Wet (29')

Displacement per
Stroke 11 l (.028 gal.)¹
Max. Flow Rate39.0 lpm (10.3 gpm)
Max. Size Solids.....1.59 mm (1/16")
¹Displacement per stroke was calculated at 4.8 Bar (70 psig) air inlet pressure against a 2 Bar (30 psig) head pressure.

Example: To pump 18.9 lpm (5 gpm) against a discharge head pressure of 2.3 Bar (34 psig) requires 4 Bar (60 psig) and 11.1 Nm³/h (6.5 scfm) air consumption. (See dot on chart.)

Caution: Do not exceed 8.6 Bar (125 psig) air supply pressure.

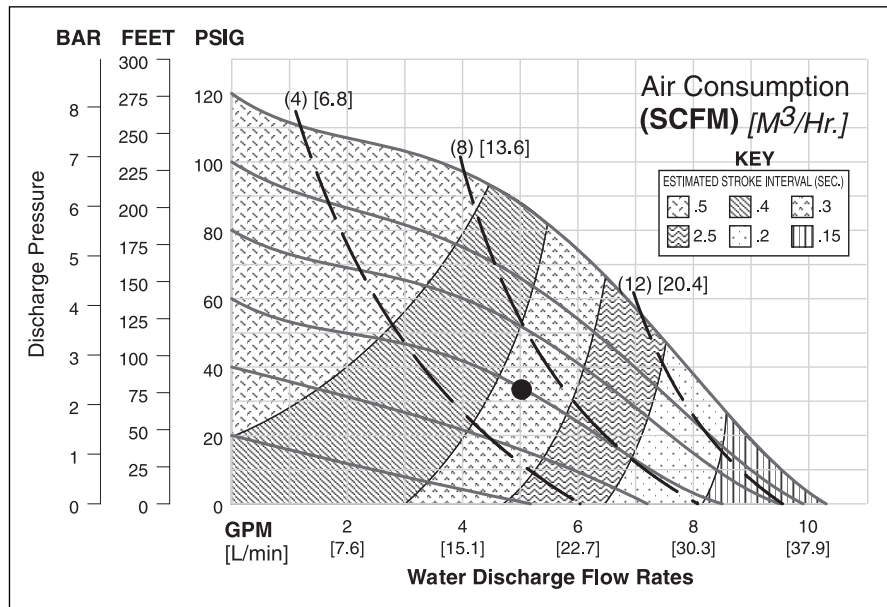

Flow rates indicated on chart were determined by pumping water.

For optimum life and performance, pumps should be specified so that daily operation parameters will fall in the center of the pump performance curve.

SECTION 6A

70/30 OPERATING CONDITION

MODEL A1T PLASTIC ACCU-FLO™

These curves demonstrate the flow created when the stroke rate is modified under static air and fluid pressure condition. This curve can be applied to different pressure conditions to estimate the change in flow due to stroke rate.

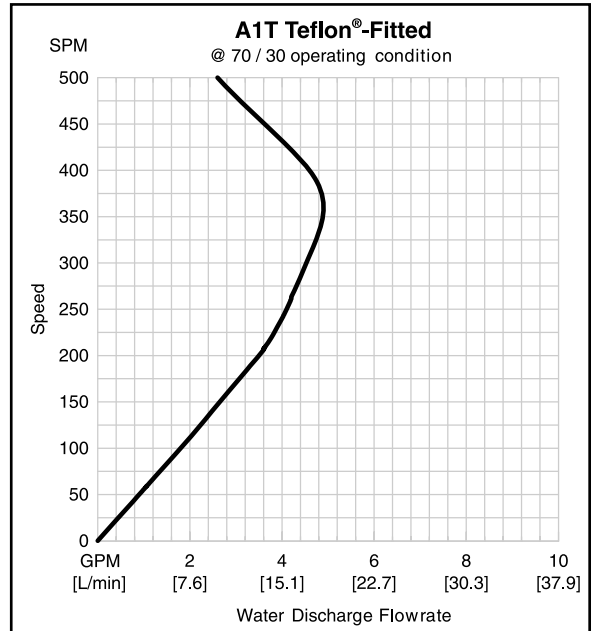
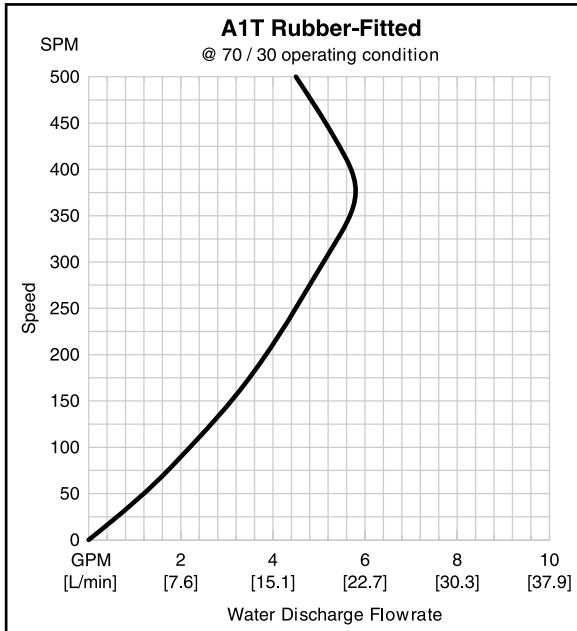

SECTION 6B

70/30 OPERATING CONDITION

MODEL A1P PLASTIC ACCU-FLO™

These curves demonstrate the flow created when the stroke rate is modified under static air and fluid pressure condition. This curve can be applied to different pressure conditions to estimate the change in flow due to stroke rate.

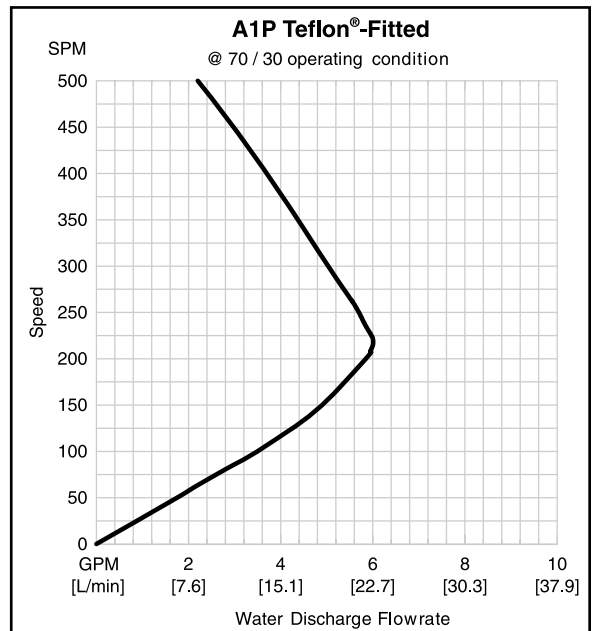
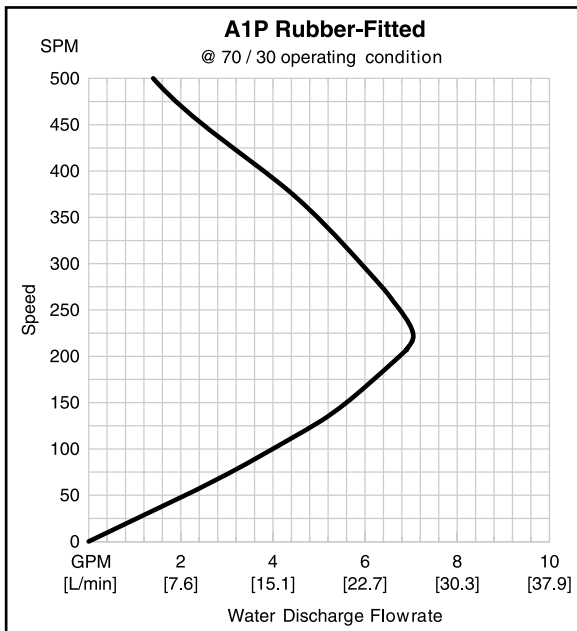

SECTION 7A

INSTALLATION

All Wilden pumps are manufactured with a variety of materials for the air distribution system, liquid path and elastomers. This variety is offered to satisfy the temperature, chemical compatibility, abrasion and flex life requirements for most applications. Consult manual for available materials and temperature limitations for this pump model.

For Accu-Flo models only, all wiring used to operate the pump should be placed and connected according to all applicable electrical codes. It is important that the wiring be of adequate gauge to carry the current required to operate the pump. In addition, it is necessary that the electrical power supply be large enough to supply the current required to operate the pump. Wiring should be above ground level if possible (in case of fluid spill or leakage), and all wiring and connections which could become wet or damp should be made watertight.

The suction pipe used for installation should be sized equal to, or greater than, the pump liquid inlet connection. This will minimize pump cavitation and potential blockages of the pump inlet. The discharge piping should also be sized equal to, or greater than, the pump liquid discharge connection. If the pump is to be used in a self-priming application, be sure that all connections are airtight and that the suction lift is within the pump's ability. (Consult manual for suction lift information.) Note: Materials of construction and elastomer materials have an effect on suction lift parameters.

INSTALLATION: Months of careful planning, study and selection efforts can result in unsatisfactory pump performance if installation details are left to chance.

Premature failure and long term dissatisfaction can be avoided if reasonable care is exercised throughout the installation process.

LOCATION: Noise, safety, and other logistical factors usually dictate that "utility" equipment be situated away from the production floor. Multiple installations with conflicting requirements can result in congested utility areas, leaving few choices for siting additional pumps.

Within the framework of these and other existing conditions, every pump should be located in such a way that four key factors are balanced against each other to maximum advantage.

1. **ACCESS:** First of all, the location should be accessible. If it is easy to reach the pump, maintenance personnel will have an easier time carrying out routine inspections and adjustments. Should major repairs become necessary, ease of access can play a key role in speeding the repair process and reducing total downtime.

2. **AIR SUPPLY:** Every pump location should have an air line large enough to supply the volume of air necessary to achieve the desired pumping rate. (Consult manual for performance information.) The use of an air filter before the pump will ensure that the majority of pipeline contaminants will be eliminated. For best results, the pump should use an air filter, regulator system.

Sound levels are reduced below OSHA specifications using the standard Wilden muffler.

3. **ELEVATION:** Selecting a site that is well within the pump's dynamic lift capability will assure that a loss-of-prime condition will be avoided. In addition, pump efficiency can be adversely effected if proper attention is not given to site location.

4. **PIPING:** Final determination of the pump site should not be made until the piping problems of each possible location have been evaluated. The impact of current and future installations should be considered ahead of time to make sure that inadvertent restrictions are not created for any remaining sites.

The best choice possible will be a site involving the shortest and straightest hook-up of suction and discharge piping. Unnecessary elbows, bends, and fittings should be avoided. Pipe sizes should be selected so as to keep friction losses within practical limits. All piping should be supported independently of the pump to avoid damage. In addition, the piping should be aligned so as to avoid placing stress on the pump fittings.

Flexible hose can be installed to aid absorbing the forces created by the natural reciprocating action of the pump. If the pump is to be bolted down to a solid location, a mounting pad placed between the pump and the foundation will assist in minimizing pump vibration. Flexible connections between the pump and rigid piping will also assist in minimizing pump vibration. If quick-closing valves are installed at any point in the discharge system, or if pulsation within a system becomes a problem, a Wilden Equalizer surge dampener should be installed to protect the pump, piping and gauges from surges and water hammer. Installation of a tee at the discharge of the pump will allow the addition of an Equalizer to the system at a later date without requiring piping modifications. Installation of inlet and discharge isolation valves are also recommended to make service and repair easier.

Pumps in service with a positive suction head are most efficient when pressure is limited to .4-.7 Bar (7-10 psig). Premature diaphragm failure may occur if positive suction exceeds these recommended pressures.

A STRAINER SHOULD BE USED ON THE SUCTION LINE OF THE SYSTEM IF THERE IS A POSSIBILITY THAT SOLIDS ENTERING THE PUMP MAY EXCEED THE PUMP'S SOLIDS HANDLING CAPABILITIES.

PLEASE READ AND FOLLOW ALL CAUTIONS NOTED IN THIS MANUAL.

Pump should be thoroughly flushed before installing into process line.

Blow out air line for 10 to 20 seconds before attaching pump to clear all pipe line debris.

SECTION 7B

OPERATING PRINCIPLES BEHIND ACCU-FLO™ PUMPS

When the solenoid is not powered, one air chamber is pressurized with air, while the opposite chamber is exhausted. When electric power is applied, the solenoid shifts, and the pressurized air chamber is exhausted while the opposite chamber is pressurized. By alternately applying and removing power, the solenoid-operated pump runs like a standard Wilden pump.

The speed of the pump is controlled electrically. Since each stroke is controlled by an electrical signal, the pump is ideal for batching and other electrically controlled dispensing applications.

Although the speed of the pump is controlled electrically, the air pressure is important. Air pressure displaces the fluid, and if the pressure is insufficient to complete the physical stroke before an electronic impulse signals the pump to shift, the stroke will not be completed, and the displacement per stroke will be reduced. This does not harm the unit in any way, but it may cause inaccuracy when attempting to batch specific quantities with high precision if this effect is not taken into account.

There are three coil voltage options available. One coil allows for 24V DC operation. The second coil option allows for operation with either 12V DC or 24V AC at 60 Hz and the third coil option allows for 110V AC operation.

ELECTRICAL CONNECTIONS

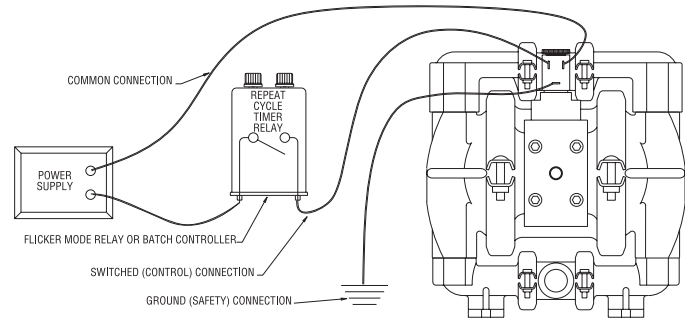

PLUMBING CONNECTIONS

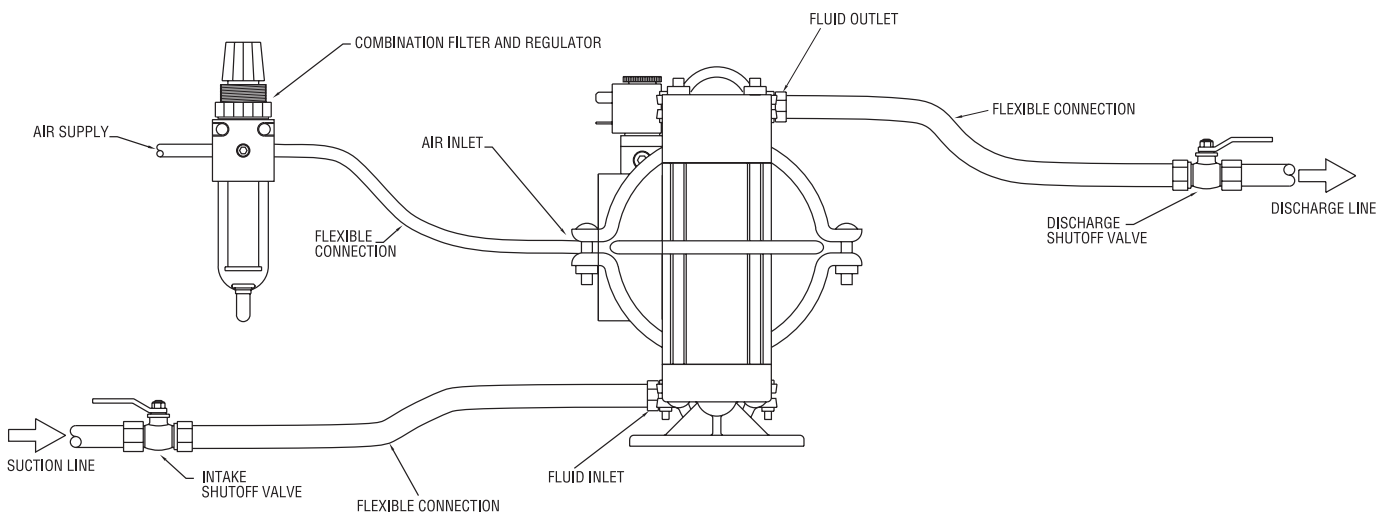

SECTION 7C - ACCU-FLO™

SUGGESTED OPERATION AND MAINTENANCE INSTRUCTIONS

A red button on the side of the air valve is a manual override; when actuated it will shift the valve as if an electric current had actuated the solenoid.

RECORDS: When service is required, a record should be made of all necessary repairs and replacements. Over a period of time, such records can become a valuable tool for predicting and preventing future maintenance problems and unscheduled downtime. In addition, accurate records make it possible to identify pumps that are poorly suited to their applications.

MAINTENANCE AND INSPECTIONS: Since each application is unique, maintenance schedules may be different for every pump. Frequency of use, line pressure, viscosity and abrasiveness of process fluid all effect the parts life of a Wilden pump. Periodic inspections have been found to offer the best means for preventing unscheduled pump downtime. Personnel familiar with the pump's construction and service should be informed of any abnormalities that are detected during operation. Internal maintenance is not recommended for Accu-Flo™ solenoid air valves. When worn or damaged, a new air valve body, coil or terminal connector must be purchased. Please consult section 9 for part numbers.

SECTION 7D – ACCU-FLO™

TROUBLESHOOTING

Pump will not run.

1. Check for pressurized air at the inlet.
2. Check air inlet and filter for debris.
3. Connect a test lamp to the two wires which run to pump and ensure that the lamp cycles on and off.
4. Make sure that the air valve manual override (small red knob on front of valve) is switched to the “0” position.
5. Check pilot pressure vent at the top of the operator/coil assembly to ensure that it is not clogged.
6. Check for a worn out air valve. If air continually blows out the exhaust in very large quantities, the air valve seals may be worn beyond their ability to function. In this case, the valve must be replaced.

NOTE: Before the valve is scrapped, it is possible that it may be saved by completely disassembling the valve, cleaning all components and relubricating the valve.

Pump runs but little or no fluid comes out.

1. Check that the discharge isolation valve is not closed.
2. Check that the electronic signal is slow enough that the pump is able to complete each physical stroke before it is signaled to change direction. The time required to complete the stroke is determined by a variety of factors which include fluid viscosity and head pressure.
3. Check for pump cavitation; slow pump speed down to match the thickness of the material being pumped.
4. Check for sticking ball check valves. If the material being pumped is not compatible with the pump elastomers, swelling may occur. Replace ball check valves and O-ring with the proper elastomers.
5. Check to make sure that all suction connections are air tight, and that the clamp bands are properly tightened.

Pump air passages blocked with ice.

Check for excessive moisture in compressed air line. As the air expands out the exhaust during the operation of the pump, water vapor entrapped in the compressed air can freeze and block the air passageways in the pump. If this occurs, it may be necessary to install a coalescing filter, an air dryer, or a hot

air generator for the compressed air.

Air bubbles in pump discharge.

1. Check for ruptured diaphragm.
2. Check tightness of clamp bands, and the integrity of the O-rings, especially at intake manifold.

Product comes out of the air exhaust.

1. Check for diaphragm rupture.
2. Check tightness of piston plates to shaft.

Pump rattles.

1. Create false discharge head or suction lift.

Solenoid buzzes or solenoid burnout.

1. Incorrect voltage, faulty or dirty solenoid.

Solenoid valve fails to shift electrically but shifts with manual override.

1. Incorrect voltage, defective coil or wiring.

Solenoid valve fails to shift electrically or with manual override.

1. Inadequate air supply, contamination, inadequate or improper lubrication, mechanical binding in the valve.

Valve shifts but fails to return.

1. Broken spring, mechanical binding.

Excessive leaking from air valve vent.

1. Worn seals in air valve.

SECTION 8A

MODEL A1 PLASTIC DIRECTIONS FOR DISASSEMBLY/REASSEMBLY

CAUTION: Before any maintenance or repair is attempted, the compressed air line to the pump should be disconnected and all air pressure allowed to bleed from the pump. Disconnect all intake, discharge, and air lines. Drain the pump by turning it upside down and allowing any fluid to flow into a suitable container. Be aware of any hazardous effects of contact with your process fluid.

The Wilden model A1 has a 12.7 mm (1/2") inlet and outlet. The single-piece center section, consisting of center block and air chambers, is molded of polypropylene. Its air distribution system is based on time-proven designs, which offer economical reliability and performance. The model A1 Plastic is available in injection-molded polypropylene and PVDF.

TOOLS REQUIRED:

5/16" Wrench

3/16" Allen Wrench

3/8" Wrench

7/16" Wrench

Adjustable Wrench

Vise equipped with soft jaws (such as plywood, plastic or other suitable material)

NOTE: The model used for these instructions incorporates Teflon® diaphragms, balls, and seats. Models with rubber diaphragms, balls and seats are the same except where noted.

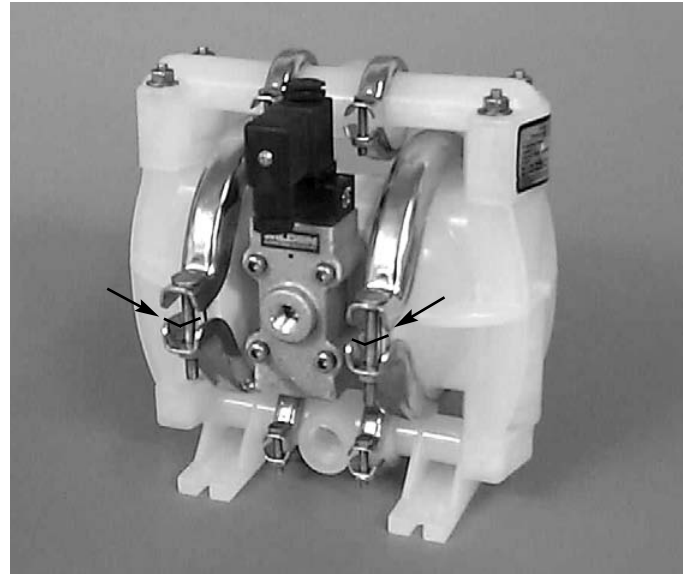

DISASSEMBLY:

Figure 1

Step 1.

Before starting disassembly, mark a line from each liquid chamber to its corresponding air chamber. This line will assist in proper alignment during reassembly. (Figure 1)

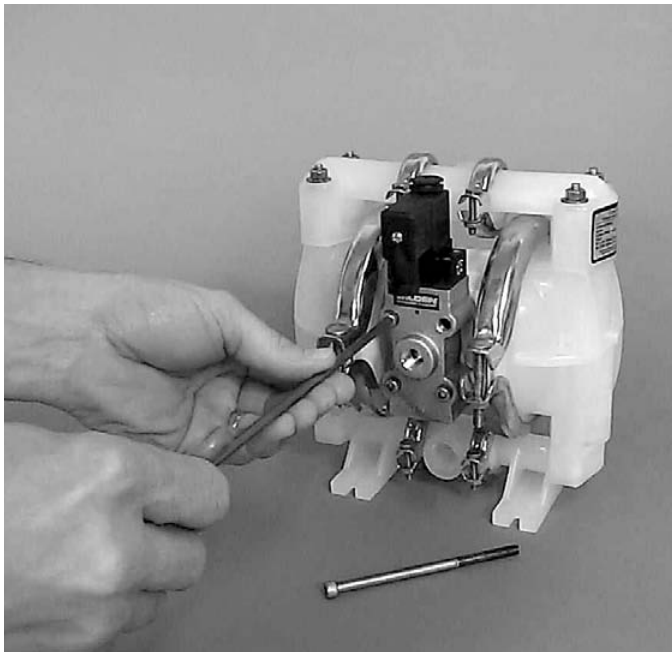

Step 2.

Figure 2

Using the 3/16" Allen Wrench, remove air valve bolts. Inspect air valve assembly for wear or damage. (Figure 2)

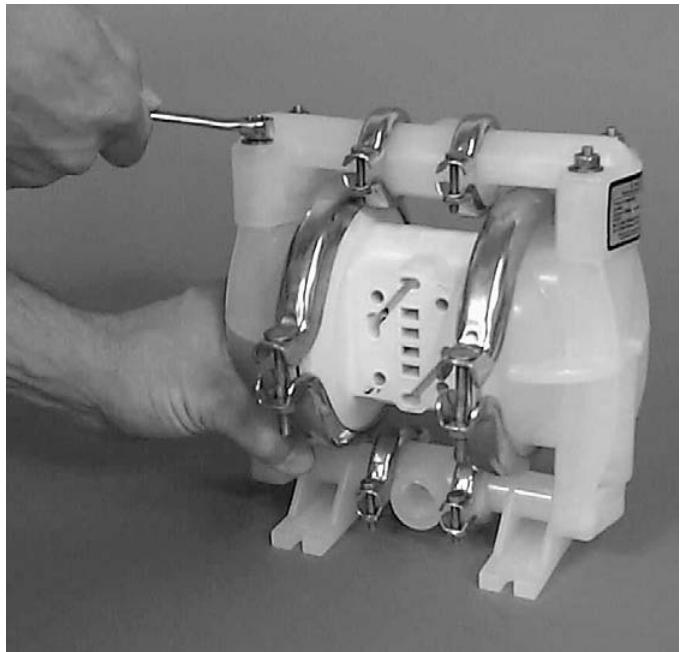

Step 3.

Figure 3

Utilizing the 7/16" box wrench, start by removing the four long carriage bolts that hold the top and bottom manifolds to the center section. (Figure 3)

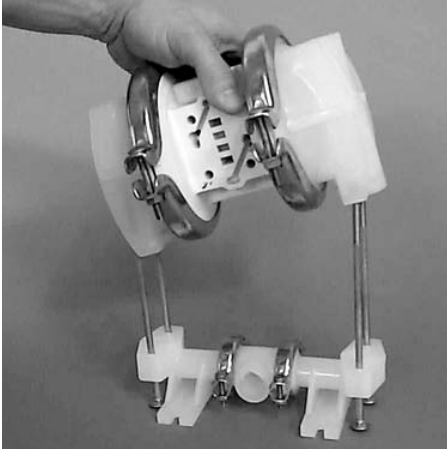

Step 4. *Figure 4*
Remove the top manifold and lift the center section off the inlet manifold. (Figure 4)

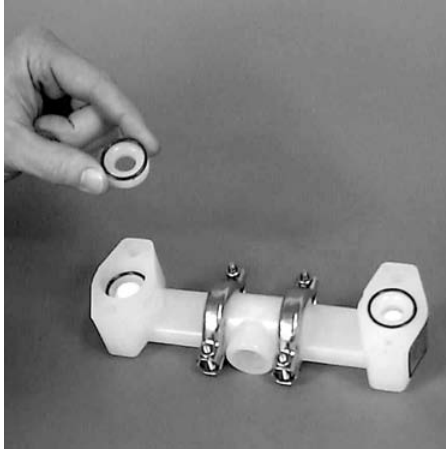

Step 5. *Figure 5*
Remove the discharge valve balls, seats and O-rings from the discharge manifold and inspect for nicks, gouges, chemical attack and/or abrasive wear. Replace worn parts with genuine Wilden parts for reliable performance. (Figure 5)

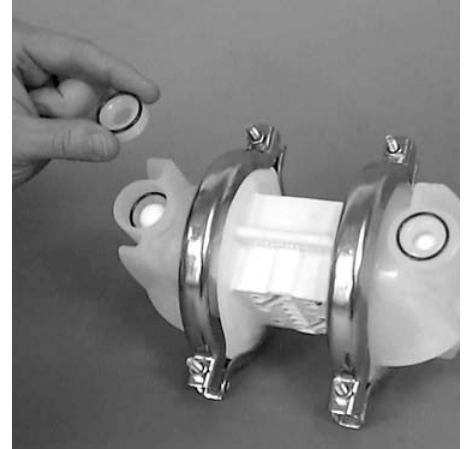

Step 6. *Figure 6*
Remove and inspect the seat, seat O-ring, and valve ball. Check for nicks, gouges, chemical attack or abrasive wear. Replace worn parts with genuine Wilden parts for reliable performance. (Figure 6)

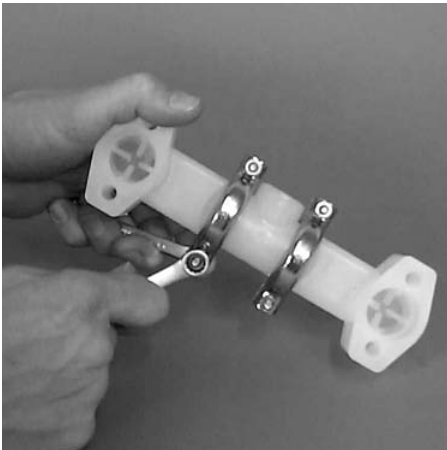

Step 7. *Figure 7*
Normally the inlet and discharge manifold should not be disassembled during regular pump maintenance. Should this be necessary completely remove and disassemble manifold clamp bands. (Figure 7)

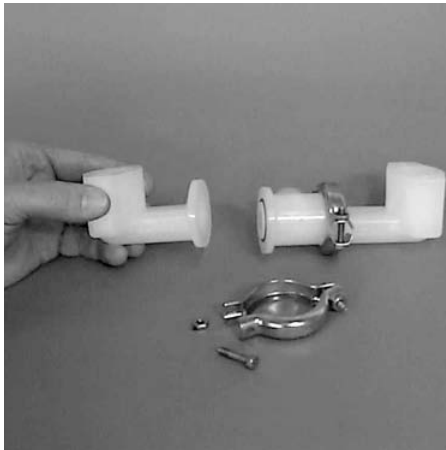

Step 8. *Figure 8*
Inspect O-rings for wear or damage and replace if necessary. (Figure 8)

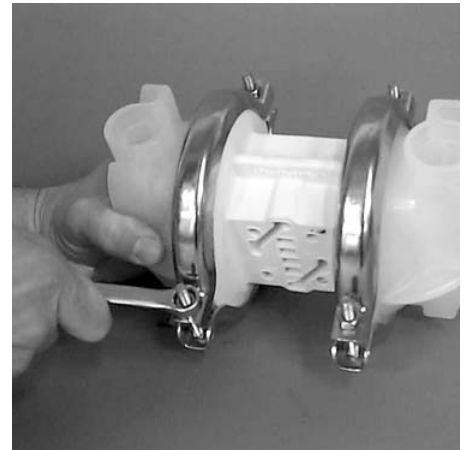

Step 9. *Figure 9*
Use a $\frac{7}{16}$ " wrench to remove one set of clamp bands that secure one liquid chamber to the one-piece center section. (Figure 9)

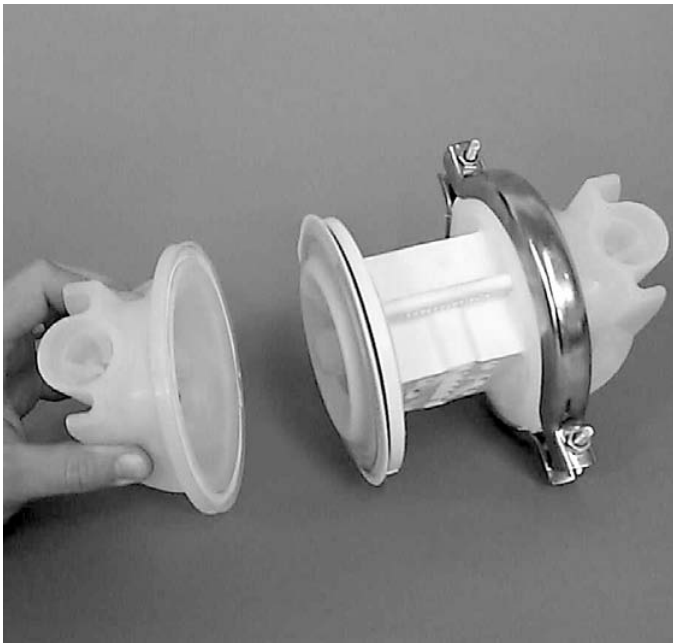

Step 10. *Figure 10*
Lift the liquid chamber away from the center section to expose the diaphragm and outer piston. (Figure 10)



Step 11. *Figure 11*
Using an adjustable wrench, or by rotating the diaphragm by hand, remove the diaphragm assembly from the center section. (Figure 11)



Step 12A. *Figure 12A*

NOTE: Due to varying torque values, one of the following two situations may occur:
1) The outer piston, diaphragm and inner piston remain attached to the shaft and the entire assembly can be removed from the center section. (Figure 12A)



Step 12B. *Figure 12B*

2) The outer piston, diaphragm, inner piston, and disc spring separate from the shaft which remains connected to the opposite side diaphragm assembly (Figure 12B). Teflon®-fitted pumps come standard with back-up diaphragms. **NOTE:** Disc spring not shown on Figure 12B.



Step 13. *Figure 13*

To remove the diaphragm assembly from the shaft, secure shaft with soft jaws (a vise fitted with plywood or other suitable material) to ensure shaft is not nicked, scratched, or gouged. Using an adjustable wrench, remove diaphragm assembly from shaft. Inspect all parts for wear and replace with genuine Wilden parts if necessary. (Figure 13)

SECTION 8B

REASSEMBLY HINTS & TIPS

ASSEMBLY:

Upon performing applicable maintenance to the air distribution system, the pump can now be reassembled. Please refer to the disassembly instructions for photos and parts placement. To reassemble the pump, follow the disassembly instructions in reverse order. The air distribution system needs to be assembled first, then the diaphragms and finally the wetted path. Please find the applicable torque specifications on this page. The following tips will assist in the assembly process.

- Clean the inside of the center section shaft bushing to ensure no damage is done to new seals.
- Stainless bolts should be lubed to reduce the possibility of seizing during tightening.
- Level the water chamber side of the intake/discharge manifold to ensure a proper sealing surface. This is most easily accomplished by placing them on a flat surface prior to tightening their clamp bands to the desired torque (see this page for torque specs).
- Be sure to tighten outer pistons simultaneously on Teflon®-fitted pumps to ensure proper torque values.

- Ensure proper mating of liquid chambers to manifolds prior to tightening vertical bolts. Overhang should be equal on both sides.
- Apply a small amount of Loctite 242 to the threads of the shaft prior to assembling the diaphragms and outer pistons.

MAXIMUM TORQUE SPECIFICATIONS

Description of Part	Plastic Pumps
Air Valve & Solenoid	2.3 N•m [20 in. •lbs.]
Outer Piston	8.7 N•m [75 in. •lbs.]
Small Clamp Band	1.7 N•m [15 in. •lbs.]
Large Clamp Band (Rubber-fitted)	7.4 N•m [65 in. •lbs.]
Large Clamp Band (Teflon®-fitted)	9.6 N•m [85 in. •lbs.]
Vertical Bolts (Kynar [Rubber only])	5.6 N•m [50 in. •lbs.]
Vertical Bolts (Kynar — Teflon®-fitted)	2.8 N•m [25 in. •lbs.]
Vertical Bolts, all Polypropylene	9 N•m [80 in. •lbs.]

SECTION 8C

GASKET KIT INSTALLATION

A1 PVDF pumps come standard with expanded Teflon® Gasket Kits (P/N 01-9501-99) for all sealing surfaces. A1 Poly pumps come standard with expanded Teflon® Gasket Kits (P/N 01-9500-99) for diaphragm bead only. Carefully prepare sealing surfaces

by removing all debris and foreign matter from diaphragm bead and all mating surfaces. If necessary, smooth or deburr all sealing surfaces. Mating surfaces must be properly aligned in order to ensure positive sealing characteristics.

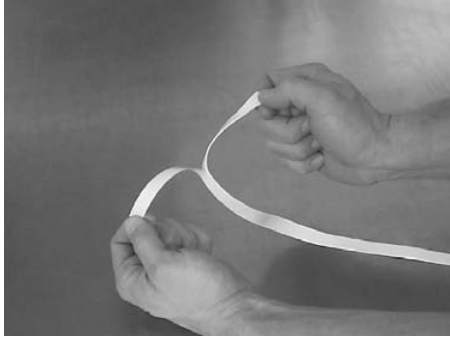

Step 1. *Figure 1*

Gently remove the adhesive covering from the back of the Teflon® tape. Ensure that the adhesive strip remains attached to the Teflon® tape.



Step 2. *Figure 2*

Starting at any point, place the Teflon® tape in the center of the diaphragm bead and press lightly on the tape to ensure that the adhesive holds it in place during assembly. Do not stretch the tape during placement.



Step 3. *Figure 3*

The ends of the tape should overlap approximately 12.7 mm ($\frac{1}{2}$ ") (*Figure 3*). Proceed to install the Teflon® tape on the remaining diaphragm.



Step 4. *Figure 4*

Carefully remove the protective covering from the back of the Teflon® gasket attached to tape. (*Figure 4*)



Step 5. *Figure 5*

Install the valve ball, valve seat and O-ring. (*Figure 5*)



Step 6. *Figure 6*

Center the gasket so that it evenly covers the O-ring and seat areas. (*Figure 6*)



Step 7. *Figure 7*

Gently apply pressure to gasket to ensure the adhesive maintains a positive seal to stay in place during pump assembly. (*Figure 7*)

MAINTENANCE RECORD

DATE	SERVICE RENDERED	SERVICED BY

SECTION 9A

EXPLODED VIEW/PARTS LISTING

A1T PLASTIC ACCU-FLO™

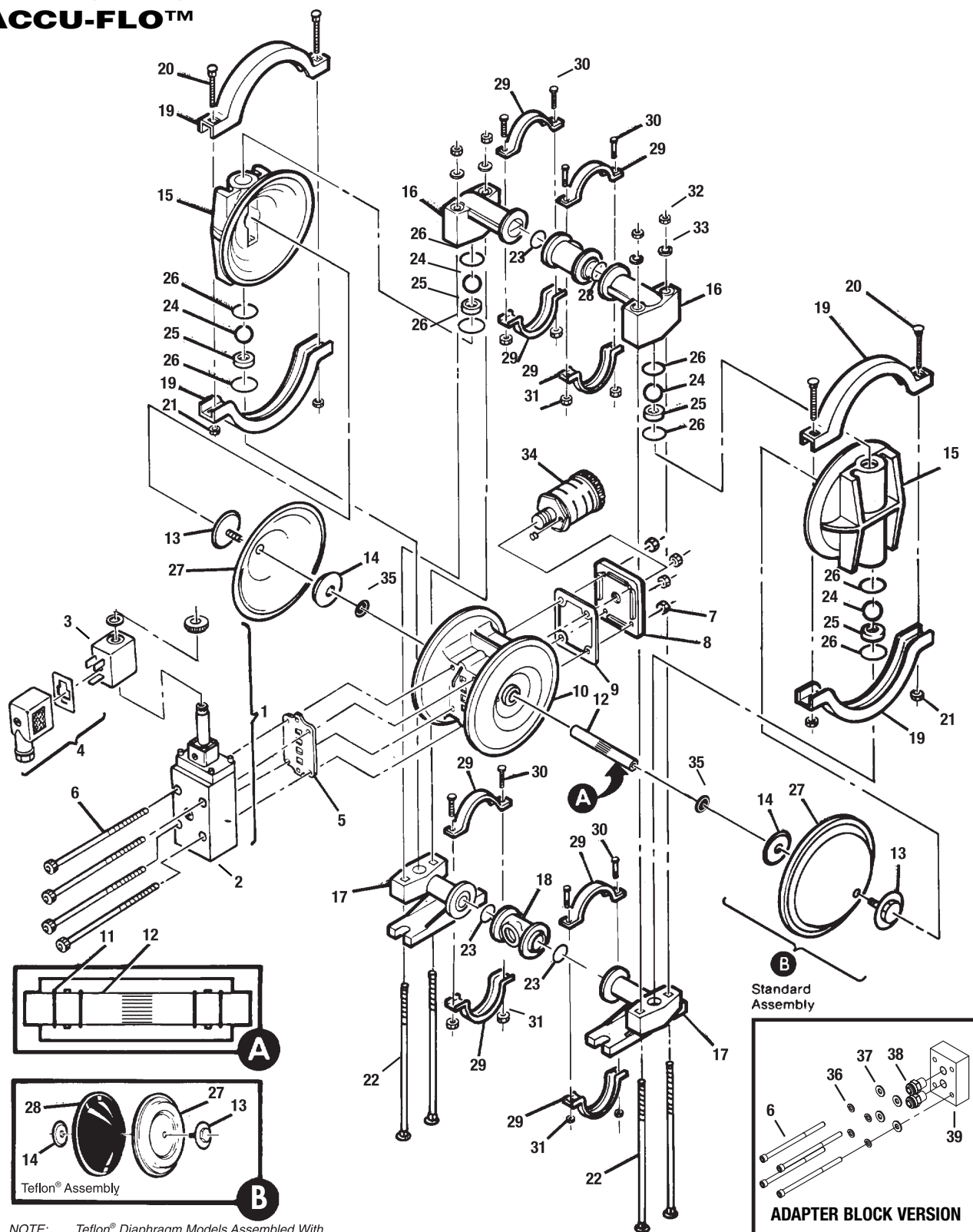

NOTE: Teflon® Diaphragm Models Assembled With Teflon® Gasket Kit At Factory (Not Shown)

MODEL A1T PLASTIC ACCU-FLO™ — DC

Item	Part Description	Qty. Per Pump	Rubber-Fitted		Teflon®-Fitted	
			A1T/PPPA-150	A1T/KPPA-150	A1T/PPPA-150	A1T/KPPA-150
			P/N	P/N	P/N	P/N
1	24 Volt DC Valve Assembly ¹	1	01-2000-99-150	01-2000-99-150	01-2000-99-150	01-2000-99-150
2	Main Valve Body	1	01-2000-01-150	01-2000-01-150	01-2000-01-150	01-2000-01-150
3	24 Volt DC Coil	1	00-2110-99-150	00-2110-99-150	00-2110-99-150	00-2110-99-150
4	Terminal Connector	1	00-2130-99	00-2130-99	00-2130-99	00-2130-99
5	Air Valve Gasket	1	01-2600-52	01-2600-52	01-2600-52	01-2600-52
6	Air Valve Screw	4	01-6000-03	01-6000-03	01-6000-03	01-6000-03
7	Air Valve Screw Nut	4	04-6400-03	04-6400-03	04-6400-03	04-6400-03
8	Muffler Plate	1	01-3180-20	01-3180-20	01-3180-20	01-3180-20
9	Muffler Plate Gasket	1	01-3500-52	01-3500-52	01-3500-52	01-3500-52
10	Center Section	1	01-3153-20	01-3153-20	01-3153-20	01-3153-20
11	Center Block Glyd™ Ring	4	01-3220-55	01-3220-55	01-3220-55	01-3220-55
12	Shaft	1	01-3800-03-09	01-3800-03-09	01-3800-03-09	01-3800-03-09
13	Piston, Outer	2	01-4570-20-500	01-4570-21-500	01-4570-20-500	01-4570-21-500
14	Piston, Inner	2	01-3710-01-150	01-3710-01-150	01-3710-01-150	01-3710-01-150
15	Liquid Chamber	2	01-5000-20	01-5000-21	01-5000-20	01-5000-21
16	Discharge Manifold Elbow	2	01-5230-20	01-5230-21	01-5230-20	01-5230-21
17	Inlet Manifold Elbow	2	01-5220-20	01-5220-21	01-5220-20	01-5220-21
18	Manifold Tee Section (Female, Threaded)	2	01-5160-20	01-5160-21	01-5160-20	01-5160-21
19	Large Clamp Band Assembly	2	01-7300-03	01-7300-03	01-7300-03	01-7300-03
20	Large Clamp Band Bolt	4	01-6070-03	01-6070-03	01-6070-03	01-6070-03
21	Large Clamp Band Nut	4	04-6400-03	04-6400-03	04-6400-03	04-6400-03
22	Vertical Bolt	4	01-6080-03	01-6080-03	01-6080-03	01-6080-03
23	Manifold O-Ring	4	*	*	01-1300-60-500	01-1300-60-500
24	Valve Ball	4	*	*	01-1080-55	01-1080-55
25	Valve Seats	4	01-1120-21-500	01-1120-21-500	01-1120-21-500	01-1120-21-500
26	Valve Seat O-Ring	8	*	*	00-1260-60	00-1260-60
27	Diaphragm	2	*	*	01-1010-55	01-1010-55
28	Back-up Diaphragm	2	N/A	N/A	01-1060-51	01-1060-51
29	Small Clamp Band Assembly	4	01-7100-03	01-7100-03	01-7100-03	01-7100-03
30	Small Clamp Band Bolt	8	01-6101-03	01-6101-03	01-6101-05	01-6101-05
31	Small Clamp Band Nut	8	01-6400-03	01-6400-03	01-6400-03	01-6400-03
32	Vertical Bolt Nut	4	04-6400-03	04-6400-03	04-6400-03	04-6400-03
33	Vertical Bolt Washer	4	01-6730-03	01-6730-03	01-6730-03	01-6730-03
34	Muffler	1	01-3510-99	01-3510-99	01-3510-99	01-3510-99
35	Disc Spring	2	01-6802-08	01-6802-08	01-6802-08	01-6802-08
36	Lock Washer ²	4	50-6760-03	50-6760-03	50-6760-03	50-6760-03
37	Flat Washer ²	4	01-6730-03	01-6730-03	01-6730-03	01-6730-03
38	Fitting, Air Inlet ²	2	00-2170-20	00-2170-20	00-2170-20	00-2170-20
39	Adapter Block ²	1	01-2150-XX*	01-2150-XX*	01-2150-XX*	01-2150-XX*
	Vent Plug (not shown)	1	01-7020-17	01-7020-17	01-7020-17	01-7020-17
	Gasket Tape & Doghnuts (not shown)		N/R	N/R	01-9500-99	01-9501-99

¹Air valve assembly includes items 2, 3 and 4.

²Adapter block version ONLY.

*Refer to Section 10 for options.

-Use 12v DC coil with FCS-II and SPC-I

All boldface items are primary wear parts.

SECTION 9B

EXPLODED VIEW/PARTS LISTING

A1P PLASTIC ACCU-FLO™

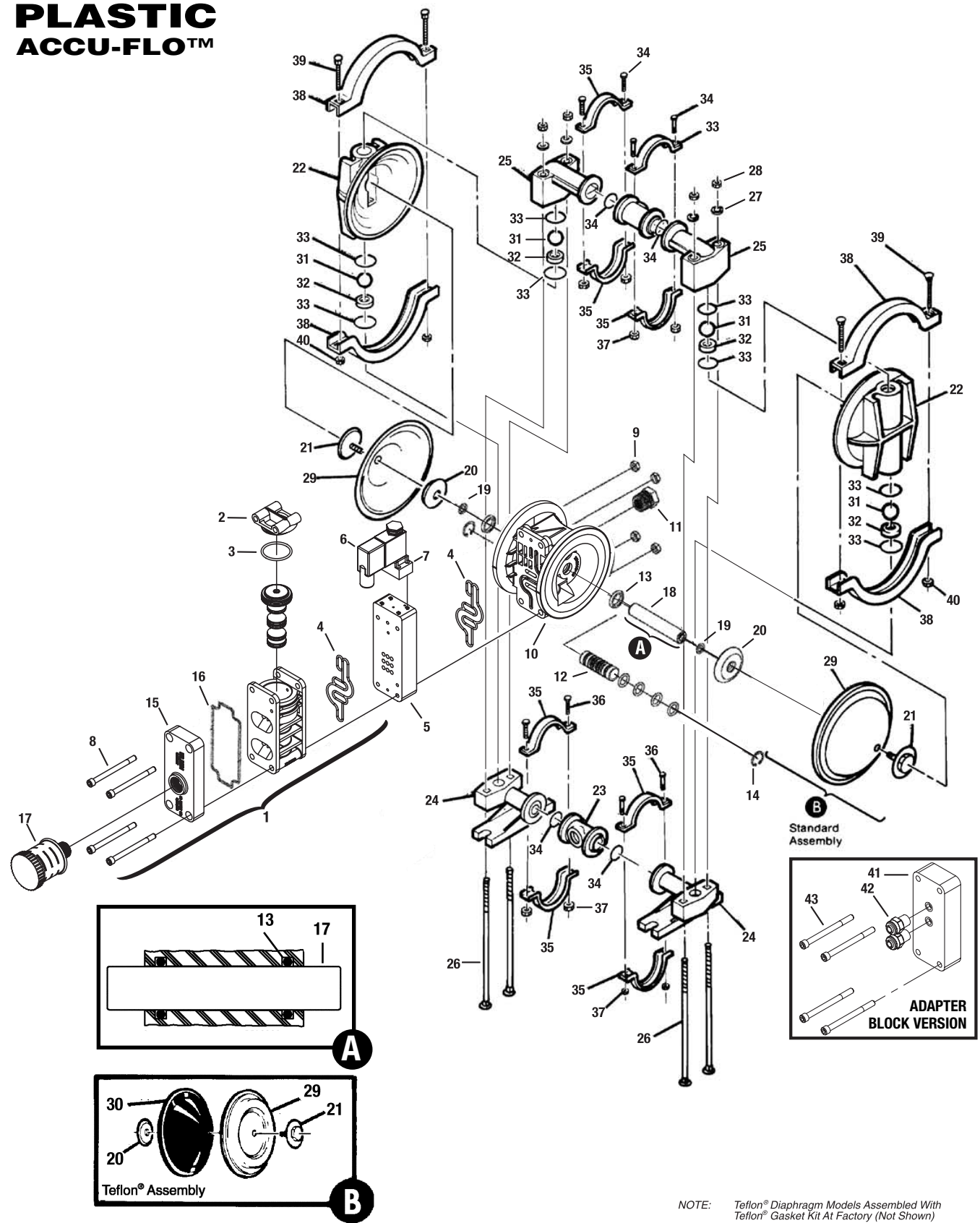

NOTE: Teflon® Diaphragm Models Assembled With Teflon® Gasket Kit At Factory (Not Shown)

MODEL A1P PLASTIC ACCU-FLO™ — DC

Item	Part Description	Qty. Per Pump	Rubber-Fitted		Teflon®-Fitted	
			A1P/PPPA-150	A1P/KPPA-150	A1P/PPPA-150	A1P/KPPA-150
			P/N	P/N	P/N	P/N
1	Pro-Flo™ Air Valve Assembly ¹	1	01-2010-20	01-2010-20	01-2010-20	01-2010-20
2	End Cap	1	01-2332-20	01-2332-20	01-2332-20	01-2332-20
3	O-Ring, End Cap	1	01-2395-52	01-2395-52	01-2395-52	01-2395-52
4	Gasket, Air Valve	2	01-2615-52	01-2615-52	01-2615-52	01-2615-52
5	Pro-Flo™ Solenoid Spacer	1	01-2160-20	01-2160-20	01-2160-20	01-2160-20
6	Terminal Connector	1	00-2130-99	00-2130-99	00-2130-99	00-2130-99
7	24 Volt DC Coil	1	00-2110-99-150	00-2110-99-150	00-2110-99-150	00-2110-99-150
8	Screw, HSHC, Air Valve 1/4-20	4	01-6000-03	01-6000-03	01-6000-03	01-6000-03
9	Nut, Hex, 1/4"-20	4	04-6400-03	04-6400-03	04-6400-03	04-6400-03
10	Center Section Assembly	1	01-3140-20	01-3140-20	01-3140-20	01-3140-20
11	Bushing, Reducer	1	01-6950-20	01-6950-20	01-6950-20	01-6950-20
12	Pilot Sleeve Plug Assy	1	01-2285-99	01-2285-99	01-2285-99	01-2285-99
13	Glyd™ Ring II	2	01-3220-55	01-3220-55	01-3220-55	01-3220-55
14	Retaining Ring	2	00-2650-03	00-2650-03	00-2650-03	00-2650-03
15	Muffler Plate	1	01-3181-20	01-3181-20	01-3181-20	01-3181-20
16	Gasket, Muffler Plate	1	01-3505-52	01-3505-52	01-3505-52	01-3505-52
17	Muffler	1	02-3510-99	02-3510-99	02-3510-99	02-3510-99
18	Shaft, Pro-Flo™	1	01-3810-03	01-3810-03	01-3810-03	01-3810-03
19	Disc Spring	2	01-6802-08	01-6802-08	01-6802-08	01-6802-08
20	Inner Piston	2	01-3711-08	01-3711-08	01-3711-08	01-3711-08
21	Outer Piston	2	01-4570-20-500	01-4570-21-500	01-4570-20-500	01-4570-21-500
22	Liquid Chamber	2	01-5000-20	01-5000-21	01-5000-20	01-5000-21
23	Manifold Tee Section	2	01-5160-20	01-5160-21	01-5160-20	01-5160-21
24	Inlet Manifold Elbow	2	01-5220-20	01-5220-21	01-5220-20	01-5220-21
25	Discharge Manifold Elbow	2	01-5230-20	01-5230-21	01-5230-20	01-5230-21
26	Screw, SHCS (Chamber Bolt)	4	01-6080-03	01-6080-03	01-6080-03	01-6080-03
27	Vertical Bolt Washer	4	01-6730-03	01-6730-03	01-6730-03	01-6730-03
28	Vertical Bolt Nut	4	04-6400-03	04-6400-03	04-6400-03	04-6400-03
29	Diaphragm	2	*	*	01-1010-55	01-1010-55
30	Back-up Diaphragm	2	N/A	N/A	01-1060-51	01-1060-51
31	Valve Ball	4	*	*	01-1080-55	01-1080-55
32	Valve Seat	4	01-1120-21-500	01-1120-21-500	01-1120-21-500	01-1120-21-500
33	Valve Seat O-Ring	4	*	*	00-1260-60	00-1260-60
34	Manifold O-Ring	4	*	*	01-1300-500	01-1300-500
35	Small Clamp Band	8	01-7100-03	01-7100-03	01-7100-03	01-7100-03
36	Small Clamp Band Bolt	8	01-6101-03	01-6101-03	01-6101-03	01-6101-03
37	Small Clamp Band Nut	8	01-6400-03	01-6400-03	01-6400-03	01-6400-03
38	Large Clamp Band	4	01-7300-03	01-7300-03	01-7300-03	01-7300-03
39	Large Clamp Band Bolt	4	01-6070-03	01-6070-03	01-6070-03	01-6070-03
40	Large Clamp Band Nut	4	04-6400-03	04-6400-03	04-6400-03	04-6400-03
41	Adapter Block ²	1	00-2155-20	00-2155-20	00-2155-20	00-2155-20
42	Adapter Block Air Fittings ²	2	00-2170-20	00-2170-20	00-2170-20	00-2170-20
43	Air Valve Bolts ²	4	04-6000-03	04-6000-03	04-6000-03	04-6000-03
	Gasket Tape & Donuts (not shown)	1	N/R	N/R	01-9500-99	01-9501-99

¹Air valve assembly includes items 1, 2, 3 and 4.

²Adapter block version ONLY.

*Refer to Section 10 for options.

-Use 12v DC coil with FCS-II and SPC-I

All boldface items are primary wear parts.

SECTION 10A

ELASTOMER OPTIONS

ELASTOMER OPTIONS FOR MODEL A1 PLASTIC PUMPS

Material	Diaphragm P/N	Valve Ball P/N	Valve Seat* P/N	Valve Seat O-Ring P/N	Manifold O-Ring P/N
Polyurethane	01-1010-50	01-1080-50	N/A	01-1200-50	01-1300-50
Buna-N	01-1010-52	01-1080-52	N/A	00-1260-52	01-1300-52
Viton®	01-1010-53	01-1080-53	01-1120-53 ¹	N/A	N/A
Wil-Flex™	01-1010-58	01-1080-58	N/A	00-1260-58	01-1300-58
Saniflex™	01-1010-56	01-1080-56	N/A	01-1200-56	01-1300-56
Teflon® PTFE ²	01-1010-55	01-1080-55	N/A	N/A	N/A
PVDF	N/A	N/A	01-1120-21-500	N/A	N/A
Teflon® Encapsulated/ Viton®	N/A	N/A	N/A	00-1260-60	01-1300-60-500

¹Must be used with part number 01-5010-21-500.

²Teflon® PTFE diaphragms require Neoprene back-up diaphragms (P/N 01-1060-51).

*Viton valve seats do not require O-rings. Must use KYNAR ball ring P/N 01-5010-21-500.

SOLENOID-OPERATED VALVE ASSEMBLY OPTIONS (CONSISTS OF VALVE BODY, COIL AND CONNECTOR)

Pump Models Designating Specialty Code #	Part Number	Description
151	01-2000-99-151	24V AC / 12V DC Valve Assembly
153	01-2000-99-153	24V AC / 12V DC Valve Assembly (NEMA 7)
150	01-2000-99-150	24V DC Valve Assembly
154	01-2000-99-154	24V DC Valve Assembly (NEMA 7)
157	01-2000-99-157	International 24V DC Valve Assembly*
155	01-2000-99-155	110V AC Valve Assembly
156	01-2000-99-156	110V AC Valve Assembly (NEMA 7)

ITEM 1 MAIN VALVE BODY OPTIONS

Part Number	Description
01-2000-01-150	Main Valve Body
01-2000-01-154	Main Valve Body (Nema 7)

ADAPTER BLOCK OPTIONS (T-SERIES)

Part Number	Description
01-2150-32	UHMW PE
01-2150-13	Acetal
01-2150-20	Polypropylene

ITEM 2 COIL OPTIONS

Pump Models Designating Specialty Code #	Part Number	Description
150	00-2110-99-150	24V DC Coil
151	00-2110-99-151	24V AC Coil
153	00-2110-99-153	24V AC, NEMA 7 Coil
154	00-2110-99-154	24V DC, NEMA 7 Coil
155	00-2110-99-155	110V AC Coil
156	00-2110-99-156	110V AC NEMA 7 Coil
157	00-2110-99-157	International 24V DC*Coil

*International 24V DC coil is explosion proof per PTB file #EX-91.C.2027

SECTION 10B

ELECTRICAL INFORMATION

NEMA 4 / UL / CSA

Part Number	Voltage $\pm 10\%$			Power (W) $\pm 10\%$	Current (A)			Resistivity (Ω)
	DC	AC			DC	AC		
		60 Hz	50 Hz			Inrush	Holding	
00-2110-99-150	24	48	44	4.8	.20	.20	.20	121
00-2110-99-151	12	24	22	4.8	.40	.40	.40	32
00-2110-99-155	60	120	110	4.8	.08	.08	.06	840

NEMA 7 / UL / CSA

Part Number	Voltage $\pm 10\%$			Power (W) $\pm 10\%$	Current (A)			Resistivity (Ω)
	DC	AC			DC	AC		
		60 Hz	50 Hz			Inrush	Holding	
00-2110-99-153	12	24	22	7	.60	.55	.32	19
00-2110-99-154	24	48	44	7	.30	.30	.18	75
00-2110-99-156	60	120	110	7	.12	.13	.06	475

INTERNATIONAL EXPLOSION PROOF / CENELEC / PTB FILE # EX-91.C.2027

Part Number	DC Voltage $\pm 10\%$	Power (W) $\pm 10\%$	Current (A)		Resistivity (Ω)
			Inrush	Holding	
00-2110-99-157	24	3.3	.135	.135	177

WARRANTY

Each and every product manufactured by Wilden Pump and Engineering, LLC is built to meet the highest standards of quality. Every pump is functionally tested to insure integrity of operation.

Wilden Pump and Engineering, LLC warrants that pumps, accessories and parts manufactured or supplied by it to be free from defects in material and workmanship for a period of five (5) years from date of installation or six (6) years from date of manufacture, whichever comes first. Failure due to normal wear, misapplication, or abuse is, of course, excluded from this warranty.

Since the use of Wilden pumps and parts is beyond our control, we cannot guarantee the suitability of any pump or part for a particular application and Wilden Pump and Engineering, LLC shall not be liable for any consequential damage or expense arising from the use or misuse of its products on any application. Responsibility is limited solely to replacement or repair of defective Wilden pumps and parts.

All decisions as to the cause of failure are the sole determination of Wilden Pump and Engineering, LLC.

Prior approval must be obtained from Wilden for return of any items for warranty consideration and must be accompanied by the appropriate MSDS for the product(s) involved. A Return Goods Tag, obtained from an authorized Wilden distributor, must be included with the items which must be shipped freight prepaid.

The foregoing warranty is exclusive and in lieu of all other warranties expressed or implied (whether written or oral) including all implied warranties of merchantability and fitness for any particular purpose. No distributor or other person is authorized to assume any liability or obligation for Wilden Pump and Engineering, LLC other than expressly provided herein.

PLEASE PRINT OR TYPE AND FAX TO WILDEN

PUMP INFORMATION			
Item # _____		Serial # _____	
Company Where Purchased _____			
YOUR INFORMATION			
Company Name _____			
Industry _____			
Name _____		Title _____	
Street Address _____			
City _____	State _____	Postal Code _____	Country _____
Telephone _____	Fax _____	E-mail _____	Web Address _____
Number of pumps in facility? _____		Number of Wilden pumps? _____	
Types of pumps in facility (check all that apply): <input type="checkbox"/> Diaphragm <input type="checkbox"/> Centrifugal <input type="checkbox"/> Gear <input type="checkbox"/> Submersible <input type="checkbox"/> Lobe			
<input type="checkbox"/> Other _____			
Media being pumped? _____			
How did you hear of Wilden Pump? <input type="checkbox"/> Trade Journal <input type="checkbox"/> Trade Show <input type="checkbox"/> Internet/E-mail <input type="checkbox"/> Distributor			
<input type="checkbox"/> Other _____			

ONCE COMPLETE, FAX TO (909) 783-3440

NOTE: WARRANTY VOID IF PAGE IS NOT FAXED TO WILDEN

WILDEN PUMP & ENGINEERING, LLC

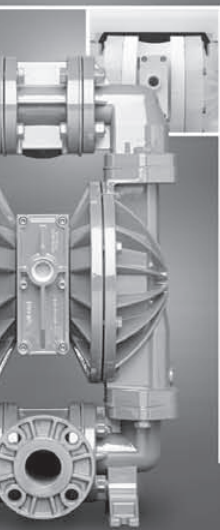

ADVANCED S E R I E S

Advance Your Process

- Advanced wetted path designs
- Lower the cost of operation
- Maximize product containment
- Longer MTBF (Mean Time Between Failures)
- Enhanced internal clearance
- The result of advanced thought

UNITEC™ S E R I E S

Enrich Your Process

- Simplicity of design
- Unique Technology
- Reliable, leak-free & quiet
- Validated & certified
- Intrinsically safe
- The result of unique thought



SANIFLO™ S A N I T A R Y P U M P T E C H N O L O G Y

Refine Your Process

- Designed for sanitary applications
- Minimize product degradation
- Improved production yields
- Easy to inspect, clean & assemble
- Minimized water requirements
- The result of progressive thought

ULTRAPURE P T F E P R O C E S S P U M P S

Optimize Your Process

- Validated & certified
- Clean room assembled
- Low particle count
- Compact, efficient & quiet
- Runs on clean-dry air
- The result of pure thought

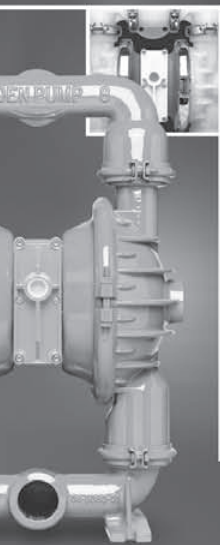
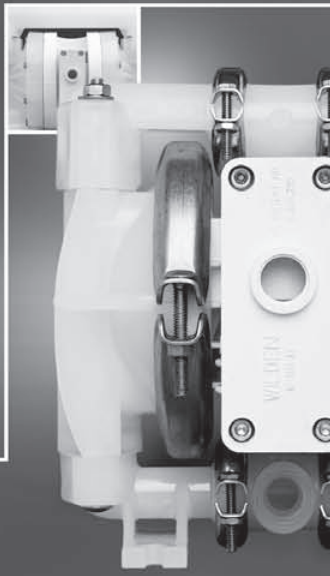

ORIGINAL S E R I E S

Simplify Your Process

- Long standing design simplicity
- Portable & submersible
- Variable connection options
- Fewest parts in industry
- Solutions since 1955
- The result of original thought

ACCESSORIES

Maximize Your Process

- Electronic control & monitoring
- Level control & containment
- Pulsation dampening
- Drum unloading systems
- Complete system solutions
- The result of innovative thought



Your Local Authorized Distributor:

WILDEN®

A DOVER COMPANY

22069 VAN BUREN STREET • GRAND TERRACE, CA 92313-5607
(909) 422-1730 • FAX (909) 783-3440
www.wildenpump.com

Printed in the U.S.A.

Copyright 2005, Wilden Pump & Engineering, LLC